This is a reproduction of a library book that was digitized by Google as part of an ongoing effort to preserve the information in books and make it universally accessible.

Google™ books

<http://books.google.com>



ALBERT R. MANN
LIBRARY
AT
CORNELL UNIVERSITY



THE

OF THE

...

The Poultryman's Handbook

A CONVENIENT REFERENCE BOOK

For All Persons Interested in the

Production of Eggs and Poultry for Market
and the Breeding of Standard-Bred
Poultry for Exhibition

BY

International Correspondence Schools

SCRANTON, PA.

1st Edition, 23d Thousand, 3d Impression

SCRANTON, PA.

INTERNATIONAL TEXTBOOK COMPANY

MANN
SF
487
I7
1912.

COPYRIGHT, 1912, BY
INTERNATIONAL TEXTBOOK COMPANY
COPYRIGHT IN GREAT BRITAIN
ALL RIGHTS RESERVED

PRESS OF
INTERNATIONAL TEXTBOOK COMPANY
SCRANTON, PA.



26987

PREFACE

This handbook is intended as a book of reference for poultrymen generally. The publishers have not attempted to produce a condensed cyclopaedia covering the broad field of poultry husbandry, but they have aimed to present to the public a handy reference book convenient to carry in the pocket—a pocketbook in reality—and containing such information as is most often needed by the poultrymen who handle fowls commercially in large numbers, by the persons who keep a few fowls in the back yard, and by the breeder who aims to produce poultry of the best quality for exhibition. Although the treatment of some subjects is of necessity brief, it has been the aim so to distribute the space available that it would cover the more important subjects as fully as possible.

The more important poultry foods are briefly described and discussed, and sample rations are given for the feeding of fowls, chicks, turkeys, guinea fowls, pheasants, ducks, geese, pigeons, etc. Much useful information in regard to incubation and brooding is given. Eggs and market poultry are discussed in some detail.

The various methods of breeding are taken up, and the enemies and diseases of poultry, together with insecticides and remedies for poultry, are discussed at some length. The various methods of poultry judging are explained, and samples of the various score cards shown. The census poultry statistics, including the number of fowls on farms in the United States and the production of poultry and eggs in the United States, are of particular interest at a time when the high cost of living is an engrossing topic of conversation.

The glossary of technical terms is a feature that will be appreciated by poultry fanciers, as it is one of the most complete glossaries of its kind that has ever been compiled. The book closes with several pages of miscellaneous information, which will be found of general interest.

This handbook was prepared under the personal supervision of Thomas F. McGrew, Principal of the School of Poultry Husbandry, assisted by Seth W. Shoemaker.

INTERNATIONAL CORRESPONDENCE SCHOOLS,
SCRANTON, PA.

November, 1912.

INDEX

A

- Accidents, 328.
- Acre, Number of fowls per, 27.
- Age of fowls, How to ascertain the, 225.
- Ailment, Definition of, 160.
- Alfalfa, 51.
- American fowls, 190.
 - Poultry Association, Membership in, 184.
 - specialty clubs, 201.
 - Standard of Perfection, 186.
- Animal foods, 52.
 - meal, 52.
- Animals destructive to poultry, 157.
- Aniseed powder, 146.
- Apothecaries' fluid measure, 295.
 - weight, 294.
- Arithmetic, 292.
- Artificial brooding, 102.
 - incubation, 86.
 - respiration, 329.
- Ash, 34.
- Asiatic fowls, 190.
- Associations, Poultry, 180.
- Avoirdupois pounds in a bushel, 295.
 - weight, 293.

B

- Bands, Identification, 212, 215.
- Bantam fowls, 196.
 - fowls, Standard weights of, 207.
- Bantams, Houses for, 24.
- Barley, 43.
- Barred Plymouth Rock female, 58.

- Beans, 44.
- Beets, 47.
- Belgian fowls, 191.
- Benzine, 149.
- Bins, Capacities of, 314.
- Birds destructive to poultry, 158.
- Black Orpington, 121.
- Bladder, Gall, 31.
- Bleeding, Hemorrhage, or, 331.
- Blood, Dried, 53.
- Bluestone, 164.
- Board measure, 311.
- Bone, Cut green, 53.
 - meal, 53.
- Brahma male, Light, 46.
- Bran, Corn, 41.
 - Wheat, 39.
- Breeding, 140.
- Brickwork, 313.
- Broilers, Classes of, 136.
- Bronchitis, 167.
- Brood coops, 99.
- Brooders, 22, 102.
 - Operation of, 105.
 - Temperature for, 105.
- Brooding, Artificial, 102.
 - Natural, 99.
 - Points in, 108.
 - Troubles in, 107.
- Broom corn, 43.
- Buckwheat, 43.
 - middlings, 44.
- Buhach, 146.
- Building paper, 4.
- Bumblefoot, 170.
- Burns, 337.
- Buttermilk, 54.

C

- Cabbage, 48.
- Cæca, 30.



- Calcimining, 307.
 Calendar, Poultryman's, 217.
 Camphor, 164.
 Canada peas, 44.
 Canary seed, 47.
 Canker, 166.
 Carbohydrates, 33.
 Carbohc acid, 150.
 Carpeting, 310.
 Casks, Gauging of, 315.
 Castor oil, 164.
 Catarrh, 166.
 Centigrade table, 302.
 Charcoal, 55.
 Chick food, Mixtures for, 62.
 Chickenpox, 170.
 Chicks, Feeding of young, 61.
 Feeding schedule for, 63.
 Weaning age of, 101.
 Chop, Hominy, 42.
 Circular measure, 297.
 Cisterns, Capacities of, 314.
 Clover, 51.
 Coal, 315.
 Cobs, Corn, 42.
 Cold frames in yards, 28.
 storage of eggs, 120.
 storage on egg prices, In-
 fluence of, 259.
 Colds, 166.
 Comparison score card, 176.
 Concentrates, 34.
 Coops, Brood, 99.
 Copper sulphate, 164.
 Copperas, 164.
 Corn bran, 41.
 Broom, 43.
 cobs, 42.
 Fodder, 51.
 Kafir, 42.
 Whole, 41.
 Cornell rations for laying
 hens, 67.
 Correspondence, 323.
 Cottonseed meal, 46.
 Cramming, Machine, 75.
 Crate fattening, 73.
 Creoline, 150, 165.
 Creosote, 148.
 fumes, 152.
 Crop, 30.
 Cross-breeding, 140, 142.
 Cubic measure, 293.
- D**
- Dalmatian insect powder
 146.
 Decimal score card, 174.
 Diffusion incubators, 90.
 Disease, Definition of, 160.
 Diseases of poultry, 160.
 Treatment of, 162.
 Dislocations, 337.
 Dorking, Silver-Gray, 132.
 Double mating, 143.
 Douglas mixture, 164.
 Dressing of fowls, 134.
 Dried blood, 53.
 Dropping-boards, 13, 20.
 Drowned persons, Restoring
 of apparently, 338.
 Dry measure, 295.
 Ducks, 198.
 Feeding of, 78.
 Standard weights of, 207.
 Duodenum, 30.
 Dutch fowls, 192.
- E**
- Egg crop, Percentage of loss
 of total, 115.
 eating, 170.
 Fertilization of the, 83.
 prices, 129.
 production as indicated by
 market receipts, 253.
 production, Monthly rate
 of, 253.
 production records, 116.
 production to season, Rela-
 tion of, 118.
 production Variations in,
 116.
 quotations, 130.
 record, Table of 3-year, 116
 yield, Fluctuation of, 114.
 Eggs, Cold storage of, 120.
 Composition of, 109.
 Food value of, 109.
 for hatching, 89.
 for incubation, 88.
 Grades of, 123.
 in a sitting, Number of, 85.
 Monthly rate of marketing
 of, 253.

- Eggs, Period of incubation of, 84.
 Period of vitality in, 84
 Pickling of, 120.
 Preservation of, 120.
 Production of poultry and, 250.
 Standards for, 122.
 Table of composition of, 110.
 Testing fertility of, 96.
 to egg production, Relation of weight of, 117.
 Uses of, 109.
 Variations in prices of, 253.
 Washing of, 113.
 Weight of, 113.
- Eggshells, Color of, 112.
 Electric shock, 334.
 Enemies of poultry, 143.
 English fowls, 192.
 money, 300.
 Epsom salts, 164.
- F**
- Fahrenheit table, 302.
 Fainting, 328.
 Fats, 33.
 Fattening, Crate, 73.
 Range, 72.
 rations, 76.
 Yard, 73.
 Feed hoppers, 14.
 Feeding 100 hens for a month,
 Cost of, 64.
 Funnel, 74.
 of ducks, 78.
 of farm flocks, 70.
 of fowls, 57.
 of fowls during molt, 71.
 of fowls in crates, 73.
 of fowls in fattening yard, 73.
 of geese, 80.
 of guinea fowls, 77.
 of laying hens, 64.
 of pheasants, 77.
 of pigeons, 81.
 of poultry for market, 72.
 of turkeys, 76.
 of wild water fowls, 81.
 of young chicks, 61.
- Feeding schedule for chicks, 63.
 schedule for laying hens, 65.
 Trough, 74.
 Feeds, Gluten meals and, 41.
 Fertility of eggs, Testing, 96.
 Fertilization of the egg, 83.
 First aid to the injured, 327.
 Fish, 54.
 Flaxseed, 45.
 Flocks, Judging of farm, 177.
 Floor materials, 5.
 Flour, 40.
 Fodder corn, 51.
 Food, Composition of, 33.
 Mixtures for chick, 62.
 principles, Uses of, 35.
 required by one hen in a year, Quantity of, 64.
 value of eggs, 109.
 Foods, Animal, 52.
 Cost of protein in, 58.
 Digestibility of, 132.
 Grain, 38.
 Green, 49.
 per quart, Weight of, 60.
 Poisonous, 56.
 Poultry, 33.
 Table of composition and nutritive ratio of green, 50.
 Table of percentage of food principles, nutritive ratio, and manurial value of poultry, 36.
 Vegetable, 47.
 Fowl, Proper way to hold a, 226.
 Fowls per acre, Number, 27.
 Standard weights of, 205.
 Fractures, 335.
 French fowls, 193.
 Fryers, 136.
 Fume insecticides, 152.
- G**
- Gall bladder, 31.
 Game fowls, 194.
 Gapes, 167.
 Gasoline, 149.
 Geese, 199.
 Feeding of, 80.

Geese, Standard weights of, 208.
 German fowls, 195.
 rape seed, 47.
 Gizzard, 30.
 Glossary, 268.
 Gluten meals and feeds, 41.
 Going light, 167.
 Gout, 169.
 Grades of eggs, 123.
 Grain foods, 38.
 Grains, Miscellaneous, 42.
 Grass, 49.
 Green foods, 49.
 Grit, 55.
 Guinea fowls, 199.
 fowls, Feeding of, 77.
 fowls, Standard weights of, 208.

H

Hand stuffing, 74.
 Hatching, Eggs for, 89.
 Hay, 315.
 Healing powders, 165.
 Heart, 31.
 Heat, 301.
 Effects of, 337.
 units, 301.
 Hemorrhage, or bleeding, 331.
 Hemp seed, 46.
 Hens, House for laying, 12.
 Homeopathic remedies, 165.
 Hominy chop, 42.
 Hoppers, Feed, 14.
 Houdan, 138.
 House for laying hens, 12.
 Open-front, 8.
 Houses for bantams, 24.
 Poultry, 2.
 Types of poultry, 8.
 Hover, 102.
 Hulled oats, 40.
 Hulls, Oat, 41.
 Hydrogen peroxide, 165.

I

Identification bands, 212, 215.
 Inbreeding, 140, 141.
 Incubation, Artificial, 86.
 Eggs for, 88.

Incubation, Factors influencing success in, 95.
 Natural, 83.
 of eggs, Period of, 84.
 Temperature for, 92.
 Incubators, 89.
 and hens, Relative efficiency of, 87.
 Diffusion, 90.
 Management of, 92.
 Moisture in, 93.
 Operation of, 94.
 Radiation, 90.
 Ventilation in, 94.
 Indian Runner drake, 221.
 Injuries, 328.
 Insect powders, Compound, 147.
 Insecticides, 145.
 Application of, 153.
 Insects attacking fowls, 144.
 Internal organs of fowls, 29.
 Intestines, 30.
 Diseases of, 167.
 Iodine, 165.
 Iron sulphate, 164.
 Tincture of, 165.

J

Judging, Methods of, 171.
 of farm flocks, 177.

K

Kafir corn, 42.
 Kerosene, 149.
 Kidneys, 31.
 Killing of parasites, 154.
 of poultry, 137.

L

Laying hens, Cornell rations for, 67.
 hens, Feeding of, 64.
 hens, Feeding schedule for, 65.
 hens, House for, 12.
 Lean meat, 52.
 Leg weakness, 169.
 Legal holidays, 320.
 weights per bushel, 229.
 Leghorns, White, 147.

Legs and feet, Diseases of, 169.
 Letter writing, 323.
 Lice, 144.
 killer, Liquid, 151.
 Light Brahma male, 46.
 Lime, Air-slaked, 147.
 Line breeding, 140.
 Linear measure, 292.
 Linseed meal, 46.
 Liquid insecticides, 147.
 insecticides, Compound, 151.
 measure, 294.
 Liver, 30.
 Long-ton table, 294.
 Lumber for poultry houses, 3.
 Lungs, 31.

M

Machine cramming, 75.
 Mangels, 47.
 Market, Feeding of poultry for, 72.
 poultry, 132.
 poultry, Classes of, 134.
 price of eggs, 129.
 Marketing of eggs, Monthly rate of, 253.
 of fowls, 209.
 of pigeons, 214.
 Markets governing egg quotations, 130.
 Masonry, 312.
 Materials, Floor, 5.
 for side walls, 4.
 Mating, Methods of, 142.
 Meal, Animal, 52.
 Bone, 53.
 Cottonseed, 46.
 Linseed, 46.
 Peanut, 46.
 Meals and feeds, Gluten, 41.
 Measures of angles or arcs, 297.
 of capacity, 294.
 of extension, 292.
 of money, 299.
 of time, 296.
 of volume, 306.
 of weight, 293.
 Meat and meat products, 52.

Meat, Lean, 52.
 scrap, 52.
 Tainted, 53.
 Mediterranean fowls, 195.
 Metric equivalents of pounds, feet, etc., 304.
 system of measures, 297.
 Middlings, 40.
 Buckwheat, 44.
 Milk, 54.
 and milk products, Table of composition and nutritive ratios of, 55.
 emulsion, 150.
 Millet, 45.
 Mineral matter, 34, 55.
 Minorca, White, 159.
 Miscellaneous bantams, 198.
 fowls, 195.
 tables, 303.
 Moisture in incubators, 93.
 Molt, Feeding of fowls during, 71.
 Morse's maxims of treatment, 162.

N

Natural brooding, 99.
 incubation, 83.
 Nests, 15, 19.
 for sitting hens, 85.
 Nitrogen-free extract, 33.
 Nursery, 102.

O

Oat hulls, 41.
 Oatmeal, 40.
 Oats, Hulled, 40.
 Whole, 40.
 Official score card, 172.
 Oils, 33.
 Ointments, 165.
 Olive oil, 164.
 Onions, 48.
 Open-front house, 8.
 Organs of fowls, Internal, 29.
 Orpington, Black, 121.
 Ovaries, 32.
 Oviduct, 32.
 Ovisac, 32.

P

- Painting, 307.
 Pancreas, 31.
 Pans, Water, 14, 19,
 Paper, Building, 4.
 Papering, 307.
 Paraffin oil, 165.
 Parasites attacking fowls,
 144.
 Effects of, 143.
 Infestation by, 143.
 Killing of, 154.
 Reproduction of, 144.
 Ridding a poultry house of,
 155.
 Peafowls, 199.
 Standard weights of, 208.
 Peanut meal, 46.
 Peas, 44.
 Persian insect powder, 146.
 Petroleum, 149.
 Pheasants, Feeding of, 77.
 Pickling of eggs, 120.
 Pigeons, Catching and hold-
 ing, 228.
 Feeding of, 81.
 Marking of, 214.
 Plastering, 307.
 Plucking of poultry, 138.
 Plymouth Rock female,
 Barred, 58.
 Rock male, White, 86.
 Poisonous foods, 56.
 Polish fowls, 195.
 Potatoes, 48.
 Poultry and eggs, Production
 of, 250.
 Classes of market, 134.
 Diseases of, 160.
 Enemies of, 143.
 foods, 33.
 -house construction, 2.
 houses, 2.
 houses, Types of, 8.
 Market, 132.
 prices, 139.
 raising, 1.
 -show rules, 181.
 shows and associations, 180.
 statistics, 240.
 Powder guns, 153.
 insecticides, 146.

- Prices of eggs, Variations in,
 253.
 Poultry, 139.
 Protein, 34.
 in foods, Cost of, 58.
 Pyrethrum powder, 146.

R

- Radiation incubators, 90.
 Range fattening, 72.
 Rape seed, 47.
 Rations, Fattening, 76.
 for hens for 30 days, 68.
 for farm flocks, 70.
 for fowls during molt, 71.
 for laying hens, Cornell, 67.
 Rectum, 30.
 Remedies for poultry, 163.
 Respiration, Artificial, 329.
 Restoring of apparently
 drowned persons, 338.
 Rheumatism, 169.
 Rhinitis tablets, 164.
 Rice, 45.
 Roasters, Classes of, 136.
 Roosts, 10, 14, 20.
 Roughage, 34.
 Roup, 166.
 Rules, Poultry-show, 181.
 Rye, 43.

S

- Salt, 56.
 Scaly leg, 169.
 Score card for farm flock, 178.
 cards, 173.
 Scrap, Meat, 52.
 Screenings, Wheat, 39.
 Seed, Canary, 47.
 Hemp, 46.
 Rape, 47.
 Sorghum, 45.
 Sunflower, 45.
 Seeds and their by-products,
 38.
 Miscellaneous, 42.
 Shingles, 5.
 Shock, Electric, 334.
 Traumatic, 330.
 Shorts, 40.
 Show rules, Poultry, 181.
 Shows, Poultry, 180.

Side walls, Materials for, 4.
 Silver-Gray Dorking, 132.
 Laced Wyandotte, 140.
 Single mating, 142.
 Sitting hen, Selection of, 84,
 hens, Nests for, 85.
 Skim-milk, 54.
 Soap emulsion, 150.
 Sorghum seed, 45.
 Soybeans, 44.
 Specialty clubs, American, 201.
 Spleen, 31.
 Sprains, 337.
 Sprayers, 153.
 Spring broilers, 136.
 Squab broilers, 136.
 Proper way to hold a, 227.
 Square measure, 292.
 Standard and non-standard
 varieties of poultry, 189.
 weights of poultry, 204.
 Standards for eggs, 122.
 Statistics, Poultry, 240.
 Stavesacre seed powder, 147.
 Storage of eggs, Cold, 120.
 Strain breeding, 140, 141.
 Stuffing, Hand, 74.
 Sulphur fumes, 152.
 Sunflower seed, 45.
 Surveyor's square measure,
 293.

T

Table of 3-year egg record, 116.
 of average price of eggs for
 1911, 266.
 of average value per fowl,
 249.
 of breeds and standard
 and non-standard vari-
 eties of poultry, 190.
 of centigrade and Fahren-
 heit degrees, 302.
 of comparative efficiency
 of incubators and hens, 87.
 of comparison of monthly
 average prices of eggs,
 130.
 of comparison of poultry
 and other foods, 133.
 of composition and nutri-
 tive ratio of green foods,
 50.

Table of composition and
 nutritive ratios of milk
 and milk products, 55.
 of composition of eggs, 110.
 of composition of fowl and
 egg, 59.
 of cost of protein in poul-
 try foods, 59.
 of digestible matter in
 wheat, 39.
 of distance of sun time be-
 tween New York City
 and other parts of the
 world, 305.
 of distances, 306.
 of feeding standards for
 young chicks, 61.
 of fowls and eggs pro-
 duced on farms in 1909,
 254.
 of legal weights per bushel,
 230.
 of loss in dressing different
 breeds of fowls, 135.
 of loss in dressing fowls, 134
 of market price of eggs,
 129.
 of market value of fowls at
 different stages, 139.
 of monthly egg records
 showing absence of uni-
 form production, 119.
 of monthly production,
 marketing, and prices of
 eggs, 261.
 of New York and London
 egg quotations, 131.
 of number and value of
 fowls on farms, 244.
 of per cent. distribution of
 fowls, 248.
 of percentage of food prin-
 ciples, nutritive ratio,
 and manurial value of
 poultry foods, 36.
 of percentage of loss of total
 egg crop, 115.
 of postal distances and
 time between New York
 and other cities, 316,
 318.
 of poultry on farms, 242.

- Table of quantity of food required by one hen in a year, 64.
 of receipts of eggs at seven leading markets, 1891-1911, 257.
 of relation of weight of eggs to egg production, 117.
 of standard weights of poultry, 205.
 of standards for eggs, 123.
 of time required to raise broilers and roasters, 136.
 of weight of poultry foods per quart, 60.
 of wholesale prices of eggs, 1896-1911, 262.
- Tables, Miscellaneous, 303.
 of weights and measures, 292.
- Technical terms, 268.
 Temperature, 303.
 for brooders, 105.
 for incubation, 92.
- Thermometers, 91.
 Thermostat, 92.
 Tincture of iron, 165.
 Tobacco dust, 146.
 fumes, 152.
- Toe markings, 209.
 punches, 211.
- Tonics, 165.
 Traumatic shock, 330.
 Treatment of diseases, 162.
 Trough feeding, 74.
 Troy weight, 294.
 Turkeys, 200.
 Feeding of, 76.
 Standard weights of, 208.
- Turnips, 47.
 Turpentine, 150, 165.
- U**
- United States money, 299.
- V**
- Varieties of poultry, Standard and non-standard, 189.
 Vegetable foods, 47.
 tops, 49.
 Vent, 30.
 Ventilation, 7.
 in incubators, 94.
 Villi, 30.
 Vitality in eggs, Period of, 84.
- W**
- Walls, Materials for side, 4.
 Water, 33.
 fowls, Feeding of wild, 81.
 pans, 14, 19.
 Weaning age of chicks, 101.
 Weights of poultry, Standard, 204.
 per bushel, Legal, 229.
- Wheat bran, 39.
 screenings, 39.
 Table of digestible matter in, 39.
 Whole, 38.
- White Leghorns, 147.
 Minorca, 159.
 Plymouth Rock male, 86.
 Wyandotte, 142.
- Whitewash, 151.
- Winter feeding, Green crops for, 52.
- Wounds, 335.
- Wyandotte, Silver Laced, 140.
 White, 142.
- Y**
- Yard fattening, 73.
 Yards, Cold frames in, 28.
 Purpose and size of, 26.
- Z**
- Zenoleum, 165.

The Poultryman's Handbook

POULTRY RAISING

Poultry and poultry products add to the wealth of the country each year more than wheat, cotton, or gold. Poultry can be kept successfully in almost every part of the world and is the most profitable kind of livestock that can be kept. A few fowls can be kept by the intensive system in very confined quarters, and enough to provide poultry and eggs for a small family can be raised profitably in a corner of a small town lot; more can be kept on a little additional space.

An attractive feature of poultry raising is that fowls may be kept for pleasure as well as profit. A fancier may use the best of all the fowls he raises for exhibition, sell a few of equal or almost equal quality to others for the same purpose, sell eggs from pens of mated fowls for hatching, and the culls of the flock will be the best of market poultry. At the same time the flock will furnish a large part of the egg and meat diet for a small family.

Poultry farming can be followed by almost any one who has a small piece of ground and a few dollars to begin with. The business should be begun in a small way and built up gradually. Thousands of men and women are becoming independent each year from a beginning with a little piece of ground on which they raise poultry and vegetables. On a small town lot 50 ft. x 100 ft. almost enough vegetables may be raised to provide for a family for a year, and at the same

time a small enclosure for poultry may be built on a corner of the lot.

It will be an advantage, in raising vegetables and poultry on a small piece of ground, to practice migratory yarding. This consists in moving the house and yards from one part of the ground to another each year. In this way the space occupied by the poultry one year will be highly fertilized for the growing of vegetables the next year, and the fowls will be benefited in health and vigor from having new, sweet earth to travel over and scratch in.

POULTRY HOUSES

POULTRY-HOUSE CONSTRUCTION

To maintain the health of fowls, their houses and runways should be free from dampness. Ground having a surface that naturally sheds water away from the buildings and yards is preferable. The best kind of soil on which to build a poultry house is a sandy loam having a sandy or a gravelly subsoil. Both the soil and the subsoil should be deep enough to permit perfect drainage. If the wash of the soil is toward a poultry house, ditches and banks should be built to turn the water away from the buildings and yards.

Poultry houses should be placed so that they will receive all the sunlight possible. In the northern hemisphere they are preferably placed on hillsides that slope gradually toward the south; in the southern hemisphere the best exposure is exactly opposite. Poultry yards should preferably extend away from the building in a southerly direction.

The natural demands of a hen are about the same as those of a dairy cow, except those due to the difference resulting from size. The hen varies, according to the breed, from 9 to 12 in. in height, and a fowl should furnish enough natural, or body, heat on the average

to make comfortable a space 2 ft. long, 2 ft. wide, and 7 ft. high. The height could be reduced, but a height of 7 ft. is necessary for the convenience of the attendant.

In constructing houses for breeds of medium or small size, such as Leghorns, Minorcas, or Bantams, it is well to allow 4 sq. ft. of floor space for each fowl. For example, fifteen fowls of this kind should have 60 sq. ft. of floor space, and twenty-five fowls, 100 sq. ft. On the other hand, a floor space of 5 sq. ft. should always be allowed for a Plymouth Rock or a Wyandotte, and one of 6 sq. ft. for a Cochin or a Brahma. Thus, while a 10' x 12' building, which provides 120 sq. ft. of floor space, is sufficiently large for thirty Leghorns, it will house only twenty-four Plymouth Rocks or Wyandottes, or only twenty Cochins or Brahmas.

So far as economy of construction is concerned, it is generally advisable to make a house as nearly square as possible. In poultry houses, however, the advantage of the square house is outweighed by other considerations, such as good, natural lighting and ventilation, which can be obtained in large houses only by making them relatively long and narrow. They should not be made too narrow, however. Under ordinary conditions, the width should not be less than 12 ft., as floor space in narrow buildings is costly. For example, a building 8 ft. x 100 ft. would cost at least three-fourths as much as one 16 ft. x 100 ft., and would furnish only one-half the floor space. If large houses are required, they should be made from 16 to 20 ft. in width and long enough to shelter the desired number of fowls.

Lumber for Poultry Houses.—For light construction, 2" x 2" uprights should be used with a 2" x 4" sill. This kind of construction will answer for small or individual buildings or for any style of poultry building that is not to be permanent, provided it is strong enough to bear the weight of the roof when there is a heavy fall of snow on it. A much more substantial framing, however, can be made of 2" x 4" studs and a 4" x 6" sill. Either barn boards, beveled siding, or jointed flooring

having a 6-in. face should be used for siding. If barn boards are used, they should always be dressed on one side, the same as the siding or flooring, so as to provide an even outer surface to the building. Either pine, hemlock, or poplar lumber is good for framing and siding; pine or cypress should be used for the flooring. In choosing lumber for poultry houses, it is always a good plan to select the kind of lumber that is least expensive, provided it will make a perfectly air-tight construction on three sides to exclude drafts.

Materials for Side Walls.—In very cold climates, double siding with one or two thicknesses of tar paper between is sometimes laid on the north wall of poultry houses. It is not unusual to place tar paper beneath the ~~one~~ layer of siding. In such cases, however, the surface of the paper not only acts as a gathering place for dust and dirt but also serves to harbor insect vermin. Such condition may be greatly prevented by sheathing the interior with flooring or by plastering the walls and ceilings. Brick or cement can be used for the side walls, but, when used, it is difficult, without the aid of artificial heat, to keep the interior dry. Dampness, as has been stated, is always undesirable for poultry. The use of lumber gives more satisfactory interior conditions and is always preferable; brick and cement walls have not proved satisfactory.

Building Paper.—The use of building paper between walls and floors is highly recommended, because it is a good non-conductor of heat and a good protector from cold and drafts. Many kinds of paper, ranging from tar paper to the heavier grades of building paper, are used for this purpose. Any of these papers will last a long time if they are carefully laid against a reasonably smooth surface. Tar paper forms a protection from insects, and for this reason it is often selected. Three-ply roofing paper or three-ply roofing felt is the cheapest of these materials that can be used to advantage for the roof or the side walls, and if it is of good quality and properly laid, it will last for many years. When

improperly laid and of a poor quality, however, it is not desirable. Roofing felt must be laid close and tight to the roof or side walls by tarring the edges, lapping them, and fastening them down well with nails and caps so that no wind, water, or snow can enter the house. Every crack or opening in the roof becomes a catch-basin for dampness instead of a protection from it.

All kinds of roofing papers will prove to be more satisfactory if they are laid with hot tar or some liquid preparation that will cause the paper to adhere to the boards. In addition to the liquid preparation, nails with tin caps must be used to hold the paper tight and firm in position, as just explained. Nothing less than a 2-in. lap of one piece of paper over the other should be allowed.

Shingles.—A good covering for poultry buildings may be made of shingles. They may be laid on strip sheathing, which is usually made of boards a foot wide and an inch thick, or on roofing lath, which is not nearly so expensive as the close sheathing. If good shingles are used and the roof is properly laid, it should do service as long as the building lasts. The life of a shingle roof may be prolonged by giving the roof a steep pitch. If the pitch is steep, the roof will drain more quickly and the material will be less likely to become water soaked. In this way, the danger of its destruction through mold or decay is lessened. If, however, the shingles are of poor quality and turn up at the ends, snow and rain will get into the poultry house.

Floor Materials.—Floors made of dirt may be used in poultry houses, provided the drainage is good and there is little danger from rats. Damp clay is commonly used in making dirt floors. This material should be well tamped, moistened, and then tamped again until level, hard, and smooth. Floors made in this way can be kept in a sanitary condition for a long time by sprinkling them with fresh, dry dirt or clean sand each time that the house is swept or cleaned. Sifted coal ashes mixed with wet clay in the proportion of 1 part ashes

and 2 parts clay, and well tamped with a heavy tamper, also make a very good floor. A tamper can be made by fitting a round handle into a block of wood. The block should be about 6 or 8 in. square and a foot long, and the handle about 3 ft. long and $1\frac{1}{2}$ in. in diameter. A hole to a depth of 3 or 4 in. should be bored into the center of one end of the block by means of a $1\frac{1}{2}$ -in. auger and the handle then driven into place.

Floors made of boards laid on 2" x 4" joists set on edge and filled between with dirt are soon undermined by rats. When using boards, it is well to fill in between the joists with cement filling or to cover them beneath the floor with close, galvanized-wire cloth or with steel lathing, to keep out rats. If floors are raised far enough above the ground to permit dogs and cats to go beneath them, there will be scarcely any danger from rats. Elevating the board floor above the ground also prevents to a limited extent the expansion and contraction that

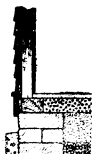

is caused by alternate damp and dry conditions. A board floor should be made of perfectly dry, well-seasoned, tongued-and-grooved lumber, with the edges laid smooth and level. Underneath the floor should be placed a layer of three-ply tar paper, and the tongue and groove of the flooring should be smeared with hot tar before the boards are nailed into place. This practice is often not followed;

nevertheless, the use of tar for this purpose always pays.

Well-laid concrete floors are decidedly the best for all kinds of poultry buildings. Their large cost makes them prohibitive in some instances, but since most farmers at the present time can do plain concreting, they are used extensively. Concrete floors should consist of four layers, as shown in the accompanying illustration. The bottom layer should be made up of stones, and the next layer of about 8 in. of coal cinders or gravel. On top of this to within 1 in. of the top should be placed 3 or 4 in. of concrete. The top layer of the floor should consist of cement and sand—1 part of good

cement to 4 parts of sand. In making concrete floors, each layer of filling as completed should be moistened and well tamped. The color may be darkened with lampblack if desired. A practice that has recently come into use is to coat the concrete with hot coal tar just before the layer of cement is put down. On top of the hot tar is laid three-ply felt, and on top of this is applied another coating of hot tar. The cement finish is then laid over the layers of tar and felt, which prevent cold or dampness from coming up through the cement. If desired, the top covering of cement can be dispensed with, and the concrete filled in and tamped until the moisture, or thin portion, is brought to the surface. When dry, concrete tamped in this manner furnishes a fairly smooth floor, but not such a perfectly level nor smooth one as can be obtained with cement and sand.

Good concrete can be made of 5 parts of sand, 2 parts of gravel, and 1 part of cement. Portland cement is preferable. The gravel, or coal ashes, whichever is used in making the second layer, should be moistened and well tamped. This kind of a floor is a perfect protection against rats.

If the concrete floor is laid prior to the construction of the building, it should extend about 1 ft. outside of the ground framework, and the building should be set on top of sills that have been laid in the cement. Concrete floors are rough and hard and are cold in winter. For these reasons, a covering of straw should be kept upon the floor; also, the roosts should be set close to the floor so that the fowls when leaving them will not light heavily upon their feet.

When cost need not be considered, asphalt, such as is used for paving, may be used for the top coat. A floor made of asphalt will be neither so hard nor so cold as one made of cement.

Ventilation.—One of the best ways of ventilating a poultry house is to use *muslin* or *cotton-cloth windows*. These windows are made by stretching the cloth over a frame made to fit the window openings. The free passage

of air through the cloth ventilates the house and prevents dampness. In winter, the temperature inside the house with cloth windows averages considerably higher than that of the outside air. Careful tests made at midnight show that while the temperature of a house with cloth windows was 6 degrees and that of a house with glass windows 14 degrees above zero, the outside temperature was 4 degrees below zero. Although the house with glass windows was 8 degrees warmer than the house with the muslin front, the advantage in temperature was more than balanced by the dampness with which it was accompanied.

Cloth windows promote the free circulation of air, which frees the interior of the house from dampness and unsanitary, unnatural conditions. The fowls within the poultry house that is ventilated by means of cloth windows have all the advantages of living in the open air and are sheltered from the dangers of such a life. Judgment, however, must be exercised in the use of cloth fronts, for if there is more cloth front to the house than is needed, the difference between the house temperature and the outside temperature will be less than that mentioned in the foregoing paragraph. Not so much open space is necessary in houses in the far North as for those in warmer localities.

TYPES OF POULTRY HOUSES

HOUSES WITH OPEN FRONTS

In Fig. 1 is shown one type of *open-front house* that may be used in mild climates. This house is 12 ft. wide and 20 ft. deep, and provides 240 sq. ft. of floor space, or sufficient room for about sixty fowls. It is built low in front—about 3 or 4 ft. high in the clear—and is 7 ft. high in the rear. The double-slant roof provides sufficient height for the interior, and at the same time has a small amount of open space overhead. The front of the house is not closed more than is shown in the

illustration, except in very cold weather, when frames covered with muslin cloth may be used inside the wire screen. The wire screen and the screen door protect the poultry from dogs and other animals. The screen door in front should be left open during the day, but it should be kept closed at night. Air passes through the open front into the whole house. The door at the side is for the attendant's use, and should be covered with heavy paper or boards during the winter months. The house, being practically air-tight, except in front, will be free from drafts, or currents of air, and the temperature inside will differ very little from that outdoors;

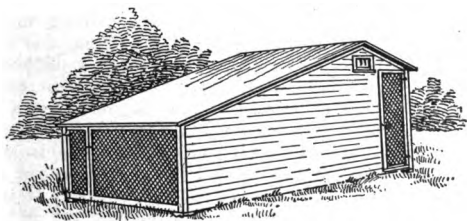

FIG. 1

also, the interior will be dry. The windows, one on each side of the house, should be kept open during hot weather, but should always be closed when it is damp, cool, or cold.

The fresh-air house, being of low, narrow construction, like a cave, is warmer naturally than a higher and narrower house with an open front; notwithstanding this, it will be scarcely 12 degrees warmer inside of a fresh-air house during a cold night than it is outdoors. The advantage derived from the use of these houses is the close approach to natural conditions in a roosting place for the fowls, although when roosting inside of a house of this kind, they are more sheltered from the elements than when roosting in the open air. The

roosting place *r*, as shown in the floor plan, Fig. 2, is far back from the open front, and even if the wind

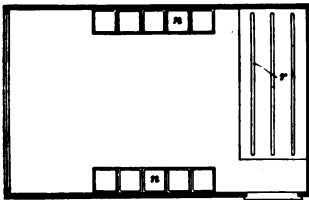

FIG. 2

blows directly into the open front, very little of it will pass into the building, as there are no openings elsewhere to form a draft. What influence the wind has is a benefit, since it drives what warmth there is in the building to the rear, and not through the house and out of the other end.

The nest boxes *n* are located on both sides of the house.

In Fig. 3 is shown another type of open-front house suitable for colder climates than the one shown in Fig. 1, the openings being covered partly with cloth and partly with glass. This kind of poultry house is most favorably considered at present, but time only can tell whether or not it will prove to be the best. It is a two-room house, but the same general plan can be fol-

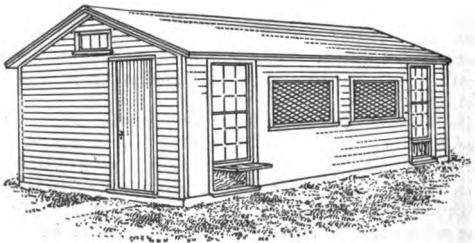

FIG. 3

lowed in constructing a long house having any number of rooms. The house shown is 6½ ft. high in the front

and the rear, 9 ft. high in the center, 12 ft. wide, and 24 ft. long. In front, near each end is a sash and glass window, and between these windows are two cloth-covered frames. Each room is 12 ft. square, and has one window opening that is closed with glass and one that is closed with cloth. Below each glass window is a smaller hinged-sash and glass window. This low-down window permits the sun to shine on the floor close to the front of the house, and also serves as an opening through which the fowls may pass. The frames

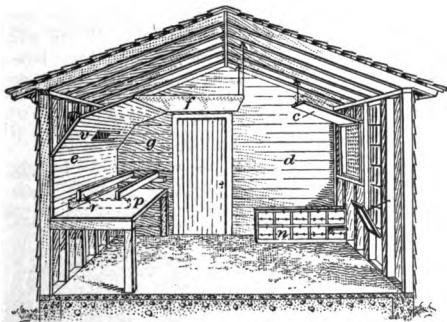

FIG. 4

on which the cloth is fastened are hinged at the top of the opening so as to turn up inside against the roof, where they are fastened when not needed to close the window openings. The large openings are covered on the outside with galvanized-wire poultry netting. The floor may be any one of the several kinds previously mentioned; preference, however, is always given to a well-laid cement floor.

The interior arrangement of this open-front house is shown in Fig. 4. The rooms are separated by the lumber partition *d*. The dropping-board is shown at *p*, and the

roosts *r* are located 8 in. above it. In the rear and above the roosts is a shelter *e*, which forms a hood about the roost. The air circulates about the roosting place, behind this shelter, and in between the studding. The interior of the roosting place is ventilated by the opening *v*. Both ends of the roosting place must be closed, as shown at the end *g*. The curtain *f* may be turned down over the front of the roosts to the level of the top of the roosts, leaving an open space between the lower edge of the curtain frame and the board *p*. When the curtain is down, the ventilator *v* in the top of the shelter should be open. The frame covered with cloth, as shown at *c*, is used to close the window opening, as previously described. The nest boxes *n* are placed 1 ft. from the partition, so as to permit the hens to get on the nests from the rear.

HOUSE FOR LAYING HENS

Although fresh-air houses may be cold during the winter months, on account of their dryness they are well adapted for laying hens. Many types of open-



FIG. 5

front houses are used. The size of the houses in the colony system, if that system is practiced, depends, of course, on the number of fowls to be provided for. A large number of hens may be housed and cared for more economically in large pens than in small ones. The one-room open-front house is especially adapted for farm flocks of poultry. The house shown in

Fig 5 is 40 ft. long, 16 ft. wide, 9 ft. high in front, 6 ft. high in the rear, and furnishes ample accommodations for 130 fowls, although 160 fowls of the smaller breeds

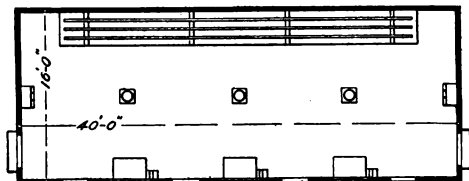

FIG. 6

can be safely kept in this house. This house may be made of any length. A house of this type 100 ft. long will be suitable for a flock of 400 to 500 Leghorn

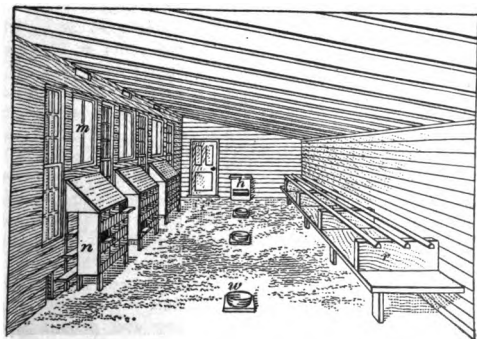

FIG. 7

laying hens, the exact number varying with the number of days in succession the fowls must be kept indoors during cold or wet weather. The house has four glass

windows alternating with three openings, each 4 ft. high and 5 ft. long. These openings are provided with two muslin-covered frames that hang from the top and which swing inwards. To prevent drafts on the fowls at night in long houses of this type, partitions are built reaching from the floor to the roof and extending from the rear wall to a point about 2 ft. in front of the roost poles. In a house 10 ft. long three such partitions will be sufficient.

The foundation for the house and the floor are made of cement. The foundation should be made so as to extend at least 1 ft. beyond the house line. After the base beams have been laid, the cement floor may be made inside of them. The floor inside the house should be at least 6 in. higher than the surrounding ground.

Fig. 6 shows the floor plan of the house and Fig. 7 shows an interior view. The roosts are shown at *r*,

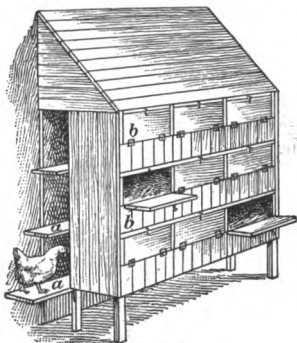

FIG. 8

feed hopper at *h*, the water pans at *w*, and the nests at *n*, where they are easily cleaned. The interior equipment should be so made that it can easily be kept in a sanitary condition. The nests are located preferably near the windows. The interior of the house is equipped with reference to speedy cleaning and proper sanitation; all equipment can be taken out of

the house. The ceiling and walls can be brushed and sprayed to insure against the accumulation of insect vermin.

Fig. 8 shows in detail the construction of the nests. They are made of light lumber and are fastened to the wall with iron hooks, thus being readily removed for cleaning. Each nest must not be less than 12 in. square; the alighting board *a* is 8 in. wide for American breeds and 6 in. wide for smaller breeds. For Leghorns, three tiers of nests may be made, and two tiers for other breeds. There should be an open space at least 10 in. in height below the nests. In using the nests, the hens alight first on the board *a* and then pass through the opening into the nests, the eggs being gathered through the doors *b*. By using this kind of nest, the eggs are kept out of the hen's sight, thereby practically preventing the formation of the egg-eating habit.

HOUSES FOR SMALL INTENSIVE POULTRY FARM

In Fig. 9 is shown a perspective view of a small house, with portable yard *y* attached, admirably adapted for use in an intensive poultry establishment on account of the ease with which it may be cared for. This house was designed originally for a conditioning

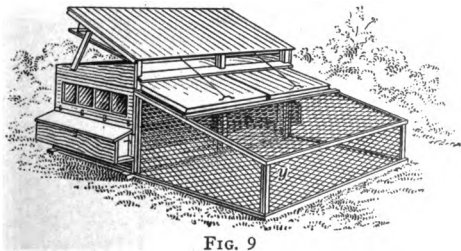

FIG. 9

coop and may be considered a modern development of the small poultry house, all the requirements for the health of fowls under all climatic conditions having been carefully considered.

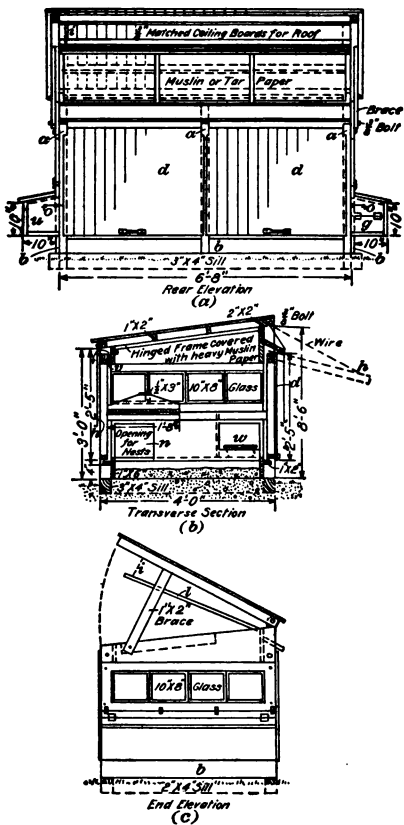

FIG. 10

When houses of this kind are used in an intensive system, brood coops are also provided, and the houses are set with sufficient space between them to allow each to be moved to the front or rear or to the side on fresh ground, so that the tainted ground can be dug up and replaced with fresh earth. Two foundations of 3" x 4" and 2" x 4" sills are made for each house, and these are set side by side or end to end, so that the houses can be moved back and forth readily.

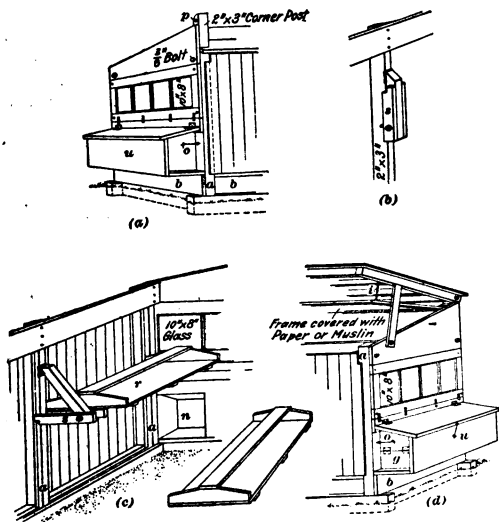

FIG. 11

Detailed drawings for the house shown in Fig. 9 are shown in Figs. 10, 11, and 12. As shown in Fig. 10, the house is 6 ft. 8 in. long, 4 ft. wide, and 3 ft. 6 in. high in front and 3 ft. high in the rear. The roof

is hinged to the front corner posts with $\frac{3}{8}$ -in. iron bolts that pass through the uprights and end frame of the roof. The frame of the building is made of light but strong wood, the uprights *a* being made of 2" x 3" material and the baseboards *b* of 1-in. material. The front and rear of the house consist of doors *d* that can be raised and lowered at will. The doors swing up from the bottom and are held open by means of an iron hook *h*, as shown in Fig. 10 (b), in which one of the front doors is represented in the open position by dotted lines; an outside view of this is shown in Fig. 9. To prevent the hook from becoming unfastened when gusts of wind shake the door, the wire is provided with a linked joint at its upper end. The hook should

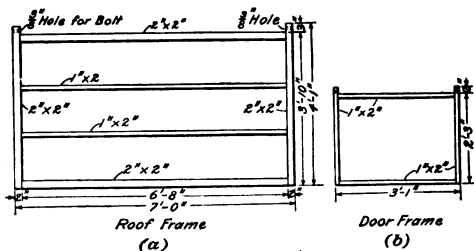

FIG. 12

always hook *under* the handle and never over it. A small hook attached to a light chain may be used as a substitute for the iron hook. The doors and roof are made of a light framework covered with thin matched boards. Plans of the roof and door frames are shown in Fig. 12 (a) and (b).

During hot weather the doors may be raised to a nearly horizontal position, thus permitting currents of air to pass through the coop, and in this position they provide shade for the fowls. The fowls may be confined to the houses when the doors are opened by

closing the door openings with a wire-covered or a slat framework. These frames should also be hinged to the upper edge of the house so as to open inside.

Perhaps the most important feature of the house is the provision made for ventilation. Openings are left above the door on each side of the building, through which air enters and passes out of the building as shown by the arrows *v* in Fig. 10 (*b*). The amount of air entering the building during cold weather and the danger from drafts may be lessened by covering the openings with a short curtain of burlap, and during particularly severe weather the opening above the door in the rear may be entirely closed by packing it. When more air is needed than can be furnished by the openings above the doors, the side doors may be opened as shown by the dotted lines in (*b*), or the roof may be raised as shown in (*c*). A frame *l* covered with cloth or heavy paper is attached to the roof by means of short chains *i*; when the roof is closed, this frame rests on slats as shown in (*b*) and forms a dead air space, which protects the fowls from cold caused by snow and ice on the roof during the winter. The frame may be removed in the summer time.

The construction of the end walls of the building is shown in Fig. 11 (*a*) and (*d*). At both ends of the house are detachable boxes *u*, one of which is arranged as a feed trough with divisions for grit, shell, etc., which the fowls can obtain from the inside of the hopper. The other box is provided with nests and a compartment for a drinking pan. The pan may be removed and filled from the outside by means of the trap door *g* in the box. The fowls have access to the water and nests through the openings *w* and *n* in Fig. 10 (*b*). The boxes are attached to the house by means of the hooks *o* and may be quickly removed for cleaning. As shown in the plans, the top of the box is hinged so that the eggs may be readily removed from the nest boxes or a new supply of food conveniently placed in the feed hoppers.

An interior view of the house is shown in Fig. 11 (c). The combined dropping-board and roost *r*, the construction of which is shown in the illustration, is made so that it may be removed readily from the house and cleaned. If possible, the dropping-board should be made of a single wide board rather than several narrow ones; cracks and crevices between narrow boards are difficult to clean. The beveled cleats on the ends of the dropping-board prevent splitting and form a support for the roost. The dropping-boards, of which there are two in each house, are each supported at one end by a cleat and at the other end by a folding bracket. The construction of the folding bracket is plainly shown in Fig. 11 (b) and (c). The dropping-board and roosts should be removed each morning and cleaned and replaced at roosting time. This will be imperative when the fowls are confined continually to the inside of the house. In the meantime, the bracket is folded up so as not to interfere with the exercising room of the fowls.

The outside of the house, including the roof, may be covered with either heavy building paper, tar paper, roofing felt, or boards; $\frac{3}{8}$ -in. matched ceiling or thin, beaded ceiling boards will be most satisfactory for this purpose, because they will last indefinitely if kept properly painted. Crude carbolic acid is a good material with which to paint them, and in fact this may be used on all parts of the house, both inside and out, because it is an insecticide as well as a stain. Crude carbolic acid may be colored almost any shade or tint desired by the addition of dry paint.

The laying house described may be used for a few hens having free range, for hens confined in small yards built about the house, or for hens that are kept constantly within the house. The keeping of a few hens and a cock constantly confined in a house of this sort is the extreme of intensity in poultry farming. The house should, of course, be properly cleaned and ventilated even when the fowls kept in it have more or less

range. Under such conditions, but one foundation is necessary for each house.

The houses should be located so that all moisture will drain away from them. Where natural drainage

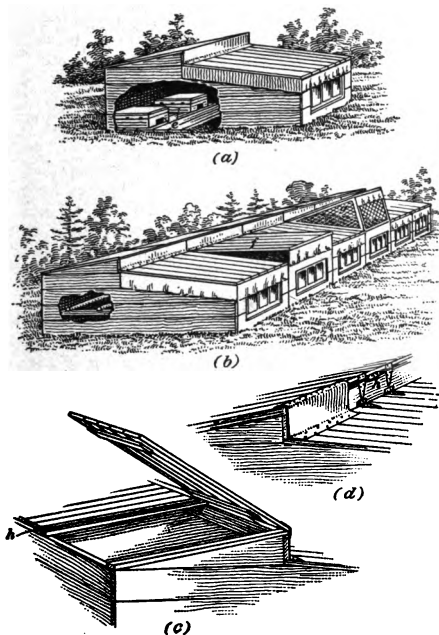

FIG. 13

conditions are not satisfactory they should be made so artificially. This can be accomplished by cutting or filling or by building terraces on which the houses

may be placed. The foundation on which the house is placed must correspond in size to that of the house. The ground inside the house should be fairly dry and free from stones and lumps of earth. It should be stirred frequently and kept loose so that the fowls will have to scratch in it when small grain is fed. When the soil inside the house becomes tainted, it should be changed as directed in a preceding paragraph. When a house is moved to the second foundation, the tainted soil of the first foundation may be freshened by passing it through a coarse sieve and by the addition of new soil; if the soil is tainted to a considerable depth it should be plowed or spaded into the ground and fresh soil put on the surface. By moving the houses frequently and by judiciously caring for the soil, the houses and surroundings may be kept in a fairly sanitary condition, and as long as such a condition exists the health of the fowls will be maintained. The vitality of fowls kept in this way will nevertheless gradually decrease.

The brood coops to be used in connection with the laying house shown in Fig. 9 may be made as shown in Fig. 13 (a). The coop shown is 7 ft. long, $3\frac{1}{2}$ ft. wide, $2\frac{1}{2}$ ft. high in the rear, 2 ft. high in the front, and 3 ft. high in the middle. Coops of this type may be made larger or smaller than the dimensions given, and they may be made single, as shown in (a), or in sections, as shown in (b); if made in sections, the coops may be thrown into one large compartment or each coop may be kept separate. The coop may have either a fixed or a movable board floor, or the ground may be used as a floor. The most satisfactory results will be obtained, especially when fireless brooders are used, if the rear half of the floor is made of boards and the other part of dirt. When the chicks are to be reared artificially without heat, fireless brooders *e* can be placed on the board floor at the rear of the coop.

The passage of currents of cold air through the coop is prevented by hanging muslin or canvas around the front of the roof; this also prevents the chicks from

jumping out when the lid is raised. A canvas curtain can also be fastened over the ventilating space along the end of the roof at the middle of the building during the cold weather. The manner of fastening this covering and attaching the hinges is shown in (d). In order to further protect the chicks from cold, an inside ceiling of burlap or canvas may be constructed as shown at (e). Grooves *h* are cut in the framework where the doors come together, as shown in (c) and (d), for the purpose of carrying off the water and preventing it from reaching the interior of the building. In warm weather, the coop may be ventilated by raising the top as shown at *f* in (b), and when the weather is very warm or the chicks are grown to maturity in the coop without liberty, it may be further raised and a wire screen *g* set in as shown. The screen is made to fold flat on the roof of the coop.

A number of these coops may be set close together or they may be placed farther apart on a range. If the coops are kept in constant use, they should be separated and moved frequently to give the chicks fresh soil. Chicks confined entirely to such close quarters as in this coop do not develop as well as those that have free or partial range. Fowls raised in this way are not as suitable for breeders as those having more range for exercise.

When fireless brooders are used, the coop should have a board floor extending half way to the front, and the rest of the space should be filled in with dry earth up to the level of the board floor. Chicks are kept warm in fireless brooders by the heat of their own bodies, which is retained by the hover. When the chicks are placed in the brooders, a T-shaped board partition is placed in front of and between the brooders to confine each brood close to its own brooder until the chicks have learned to go outside for food and inside for warmth. When the chicks have grown a coat of feathers, the brooder boxes are removed and roosts installed as shown in Fig. 13 (b).

HOUSES FOR BANTAMS

A small house is suitable for bantams; the smaller the house, the less space there will be for their bodies to heat up, and the more comfortable they will be during very cold nights. The box house illustrated in Fig. 14 can be built out of packing cases that are $3\frac{1}{2}$ ft. wide, $4\frac{1}{2}$ ft. long, and of the average height, the front elevation of the building being $4\frac{1}{2}$ ft. and the rear elevation $3\frac{1}{2}$ ft. The floor of the house, which is made first, is 4 ft. wide and 5 ft. long, and is elevated 12 in. above the ground by cleats nailed all around on the under side flush with the edge. The walls of the house are nailed to the edge of the floor, the boards in

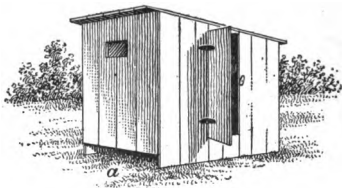

FIG. 14

the rear and on the sides resting on the ground, closing the space under the floor on three sides. In front, the boards extend 6 in. below the floor and to within 6 in. of the ground, leaving an open space *a* of 12 in. under the floor. When the siding is in place the roof is put on and covered with roofing paper.

One $8'' \times 10''$ pane of glass in front admits all the light that is needed; the single-board door admits the bantams and permits the gathering of the eggs and the cleaning of the house. A round roost pole across the rear end and some small nest boxes completes the house. This house will provide quarters for ten or twelve bantams. It can be moved beneath the shelter of a

tree during the summer months, placed under a shed or moved to the basement during the severe cold weather, or left in the open throughout the entire year. It is, in fact, a comfortable house for bantams in all kinds of weather. The dust bath for the bantams is beneath the house. When the nights are cold the open space *a* in front should be closed. In localities where it is very cold, and where there are spells of severe weather, the outside of the box should be covered with tar paper to close the cracks against the wind.

For Brahma or Cochin Bantams, a low, compact house is the best. These bantams can withstand the coldest weather if they are as well protected as are other fowls.



FIG. 15

The house shown in Fig. 15 is 8 ft. long and 6 ft. wide; it is $6\frac{1}{2}$ ft. high in front and 5 ft. high in the rear; the fence for the enclosure is 5 ft. high. If desired, this house can be divided through the middle and be used for two separate lots of bantams. When this is done, a division fence should separate the two pens. The interior of the house may be arranged to suit the convenience of the poultryman. The building has a double door, the inner screen door *a* swinging to the inside and the board door swinging to the outside. The outer door should be left open during warm weather and on bright days during cold weather to prevent dampness. The house should have a board floor.

YARDS FOR POULTRY HOUSES

Purpose and Size of Yards.—Fowls are confined in yards to prevent them from trespassing and from going where they may do harm or where they may injure themselves. They are also confined when an effort is being made to secure a large egg yield by intensive methods, and when several varieties of fowls are kept for breeding purposes, in which case the flocks must be kept separate in order that each breed may remain pure.

Yards cannot be too large and are frequently too small. Less than 100 sq. ft. of yard room per head is not enough to secure the best results in producing eggs; a yard 50 ft. wide and 100 ft. long will be sufficient for fifty hens, provided special care is taken to keep the soil in a sanitary condition. If the yard is 100 ft. square, the fifty hens will do much better. Two and one-half acres will answer much better for five hundred hens in one flock than the same space divided into ten yards for fifty hens each. The reason for this is that when the five hundred hens are confined in the space of $2\frac{1}{2}$ A., each one has the free range of the entire area, and when the space is divided into ten yards, each fowl is confined to a space about equal in size to that of an ordinary town lot.

Close confinement causes the flock to become discontented, and overcrowding the yard lessens the egg yield. If either one or both of these conditions is of long duration, the health and vitality of the fowls is undermined and destroyed. Asiatic fowls can be kept in health and vigor in much less space than can the American varieties; Leghorns must have more than double the space that is necessary for other varieties. These remarks apply to the keeping of laying hens and not forcing a few fowls to an early maturity for the market on a space so limited that they neither produce eggs nor maintain vitality. The more closely hens are confined, the greater the necessity for cleanliness, care, and proper feeding.

Number of Fowls per Acre.—The number of fowls that are kept on 1 A. by intensive methods varies considerably. Under most conditions 500 fowls is a large number to keep on an acre. The number of fowls that can be successfully kept per acre depends to some extent on the purpose for which the fowls are kept. Fewer laying hens can be kept on an acre than fowls that are intended only for market poultry. As many as 1,000 laying hens have been kept on an acre with fair success. Some instances are recorded where more than this number have been kept on an acre, but the common yield of hens so kept never equals that of hens that are equally well cared for on a larger area.

As many as several thousand broilers can be raised to marketable size on an acre of ground in a single year when houses suitable to the purpose are used, but even among most skilful poultrymen there is seldom any attempt to raise as many as this on an acre.

In some systems of poultry raising, as many as 650 half-grown and mature fowls are confined upon a plot of ground 50 ft. wide and 60 ft. long. This allows only 3,000 sq. ft. for 650 fowls, or but a trifle over 4.6 sq. ft.

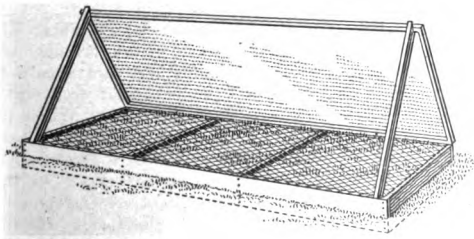

per fowl. This is at the rate of 9,400 fowls to the acre. Under such conditions the problems of sanitation and providing the fowls with sufficient exercise are very serious.

Cold Frames in Yards.—Each yard or runway of small size should be provided with a cold frame for producing a daily supply of green food for the fowls. Such a frame is shown in the accompanying illustration. It is made of boards 1 in. thick and 9 in. wide. The frame may be made of any desirable dimensions, the one shown being 12 ft. long and 4 ft. wide. The frame is set from 3 to 4 in. into the ground and the top is at least 6 in. above the ground. To produce green food, the soil in the frame is thoroughly dug up and cultivated to provide a fine seed-bed. Oats, wheat, rye, or barley, with which has been mixed Red clover seed, or the screenings from these grains, is then sown thickly to produce a close growth of plants. After the seed has been raked in a wire-covered frame is placed over the top. The seed-bed is watered daily, both morning and evening, and this is continued until the plants finish their growth. The top of the frame is kept covered with muslin cloth until after the seed has sprouted.

After the seed has sprouted the cloth is removed and a more plentiful supply of water is sprinkled over the bed each time they are watered. As soon as the plants appear through the netting the fowls peck at and eat them. The mesh of the netting used should not be greater than 1 in., and a smaller mesh is preferable. The fowls should be prevented from reaching through and pulling the plants from the ground and care should be taken to have the netting stretched tight to keep it from sagging from the weight of the fowls. When the vitality of the plants in the cold frame has been exhausted the bed can be replanted and a fresh supply of green food grown. When plants are grown in this way the quickness of their growth depends largely on a regular and plentiful supply of moisture. If this requirement is overlooked and the ground becomes dry enough to cause the plants to wilt, no amount of moisture or care can put them in a good condition again.

INTERNAL ORGANS OF FOWLS

The process of digestion in poultry differs materially from that in animals that chew their food. Fowls have no teeth, the functions of the teeth being performed by the gizzard, in which, by the aid of grit, the food is

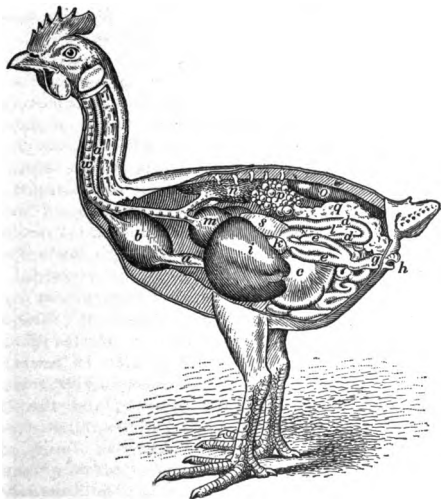

FIG. 1

ground into pulp. The greater part of the food eaten by poultry is swallowed whole and passes in that condition to the crop, where it absorbs considerable moisture before it passes to the other digestive organs. A general view of the internal organs of a hen is shown in Fig. 1. After being picked up by the bill, the

food passes through the upper part of the esophagus *a* into the crop *b*; from the crop the food passes through the lower part of the esophagus into the gizzard *c*; and from there through the other organs of the digestive system.

Crop.—In fowls and other granivorous, or grain-eating, birds, the crop is relatively larger than the crop of birds that feed largely on grass. Within the crops are juices that moisten the food and hasten its passage into the gizzard.

Gizzard.—The gizzard *c* may be looked on as a powerful grinding machine in which the whole grain and other foods of poultry are ground, oftentimes finer than they would be ground by the teeth of chewing animals. The grinding is accomplished by means of the powerful muscles of the gizzard, which keep the mixture of sand, grit, and food within it constantly in motion. In the gizzard the food is also acted on by digestive juices before being passed into the intestines.

Intestines.—The intestines as applied to fowls means all of the alimentary canal beyond the gizzard. The intestines of the fowls, although different in many respects from those of other animals, present a somewhat similar appearance and have functions nearly identical with those of the other domestic animals. In fowls, the intestines are made up of the *duodenum*, and the rest of the *small intestines d*, the *caeca e*, and the *large intestines* and the *rectum g*. Inside of the intestines the food is acted on by various digestive fluids, and digestible nutrients within the food are taken from it and eventually converted into blood. The inner walls of the intestines are covered with minute projections known as *villi*, which absorb the digested material from the contents of the intestines. The indigestible part of the food passes into the rectum *g* and out of the body through the vent *h*.

Liver.—The liver *i* is a large, two-lobed organ of peculiar cellular structure. It has two offices, one of them being to purify the digested material brought to

it by the capillaries, and the other to secrete the bile, an important digestive fluid. The liver must be kept in a healthy condition or the blood, and consequently the entire system, will speedily become poisoned.

Gall Bladder.—The gall bladder *k* serves as a reservoir for the bile secreted by the liver, to which it is closely attached. The bile is passed, as needed, from the gall bladder to the intestines, where its special office is to break up the vegetable fats and oils and convert them into soluble animal fat, which is readily made a part of the fowl's body.

Spleen.—The spleen *s* is located near the liver and is an organ whose use is not definitely known. It is thought, however, that it is useful in producing certain modifications in the blood.

Pancreas.—Situated among the folds of the small intestines is the pancreas *l*, a small organ of insignificant appearance. This organ is of vital importance, for in it is secreted the pancreatic juice, which flows from the pancreas into the intestines, where it acts directly on the starchy portions of food, and to a limited extent on protein; it also aids in the absorption of fat. The juice from the pancreas unites with the bile and they together flow over the foods as they come from the gizzard.

Heart and Lungs.—The heart *m* and the lungs *n* are vital organs. The work done by the latter, like that of the liver, consists in purifying the blood. The office of the heart, as is well known, is to pump the blood to all parts of the body. The heart, lungs, and liver may be considered as the most important organs of the body, and care should be taken to keep them in good working order, for when the action of one of these organs is faulty, the effect is soon apparent on the others. The air is supplied to the lungs through the windpipe *w*.

Kidneys.—The kidneys *o* are located in cavities in the pelvic bone. They act on the blood and separate from it liquid waste material, which is eventually passed from the body through the vent.

Ovaries and Oviduct.—The ovaries *p* and the oviduct *q* are shown enlarged in Fig. 2. The ovaries *a* (Fig. 2) are attached to the under side of the backbone, usually

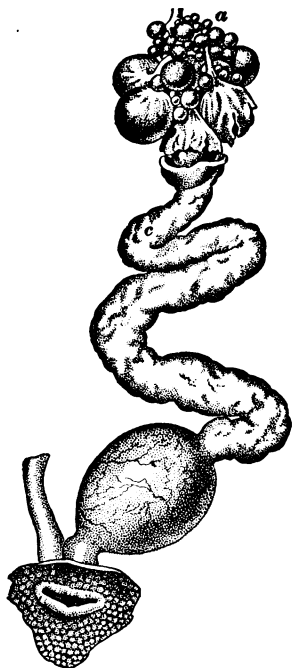

FIG. 2

on the left. The ovaries and the oviduct are the female organs of reproduction. The yolk of the egg attains its full size within the casing of the ovaries, which, in good laying hens, contain yolks varying in size from that of a small pin head to that of the full-grown yolk. As soon as the yolk has reached its full development, the casing of the ovary, or *ovisac*, as it is sometimes called, opens and the yolk passes into the oviduct *c*. The yolk may or may not be fertilized by the male element before or just after entering the oviduct.

The oviduct varies in length, and in some cases it is nearly 2 ft. long. As the yolk passes through the oviduct it becomes covered with albumen, of which the white of the egg is composed, and with a double membrane, or the lining to the egg-

shell. After the egg has reached its full size the shell is formed about it in the oviduct. The passage of the egg through the oviduct requires from 6 to 18 or 20 hr.

POULTRY FOODS

COMPOSITION OF FOOD

Food is any substance that a plant or an animal may take into its body and use for building up wasted tissues and maintaining natural conditions. Besides water, which is present in all foods, the different compounds of which solid animal foods are composed have been grouped into four classes: carbohydrates, fats, protein, and ash. All the compounds belonging to these classes of food elements, or principles, are not completely digestible, and the value of poultry food is determined largely by the amount of these food constituents that can be digested by the fowls.

When food is digested it forms blood, which circulates throughout the body and sustains life. By means of the blood the nutritious portions of the food are assimilated, or incorporated into the body of the fowl for the purpose of nourishing it and for renewing wasted tissues. Eggs are composed largely of the same kind of materials that are utilized in the formation of blood and flesh.

All foods contain *water*; dry grains, meals, and hays contain from 7 to 10%, and grasses, green plants, roots, and unripened grains contain from 60 to 70%. The flesh of fowls and their eggs are from 41 to 65% water, 1 doz. new-laid eggs containing almost 1 lb.

The greater portion of the solid part of poultry food is composed of *carbohydrates*, or *nitrogen-free extracts*, as they are sometimes called. Carbohydrates are made up largely of starch, sugar, gums, vegetable acids, and crude fiber. Carbohydrates are used by fowls to supply energy, to produce animal fats and oils, and to maintain the body heat.

The food elements known as *fats*, or *oils*, differ from carbohydrates in being able to produce more heat. For

this purpose, 1 part of fat is equal to $2\frac{1}{4}$ parts of carbohydrates. For this reason, when estimating the heating value of foods, it is customary to multiply the amount of fat in them by $2\frac{1}{4}$ in order to express its equivalent in carbohydrates.

That portion of food which contains nitrogen is known as *protein*. The lean meat of the fowl and the white of the egg are composed largely of this principle. As a source of heat and energy, protein is about equal to the carbohydrates, but animal heat obtained from protein is very expensive. Protein is much more costly than the carbohydrates and fats, and no more of it should be fed to fowls than is absolutely necessary to renew waste, make new growth, and furnish the needed quantity for egg formation.

That part of food which would be left if the food were burned is called *ash*, or *mineral matter*, and it contains calcium, magnesium, potassium, sodium, iron, and other elements. When assimilated by fowls, ash enters largely into the composition of bones and the shells of the eggs. There is not enough ash for egg and bone formation in the food usually fed to fowls, and for this reason it is necessary to supply them with such materials as oyster shells, clam shells, limestone grit, etc.

Foods that contain a large proportion of crude fiber are spoken of as *roughage*, and those that contain little crude fiber and that are nearly all digestible are known as *concentrates*. Clover hay is an example of roughage; corn meal is an example of a concentrate. Although of little direct value as a food for poultry, roughage, or crude fiber, is important in a food because in passing through the digestive organs it distends them and serves as an irritant that stimulates their mechanical action and assists them in digesting their contents.

When feeding fowls it is always best to have a sufficient quantity of ash, fiber, and roughage in their rations to extend the crop and to keep the gizzard actively employed in grinding. During the process of

grinding the coarse foods become thoroughly mixed with the concentrated foods and all pass through the intestines in a manner that makes their assimilation much more natural and, therefore, of more real benefit to the fowls than would be the case without them.

Clover and alfalfa hay and bran are very highly considered as roughage for poultry, and they not only well serve the purposes mentioned but are also valuable as food. Clover and alfalfa contain a large percentage of ash and fiber and are among the best substitutes for green food as well; although but little of the bran is digested, it is most valuable as an intestinal irritant.

When feeding clover or alfalfa hay it is well to throw bundles of these into the houses on the litter and permit the fowls to pick the leaves and scratch in the hay as they do in the litter.

Uses of the Food Principles.—After being digested and absorbed by the blood vessels, the different food principles are used by the body for various purposes. From protein are formed the muscles, or lean meat, and this principle also enters largely into the composition of the bones and feathers, and, most important of all, the egg. Protein can be more completely utilized than the other food elements and some hens seem to have the power to utilize practically all of the protein contained in the food they eat.

Carbohydrates are mainly used to keep up the body temperature. The utilization of carbohydrates for this purpose is really a slow form of burning, which is just as necessary for the life of the fowl as the fire beneath the boiler is for the running of the steam engine. Carbohydrates are also the source of much of the energy used when the fowl moves itself about and performs other work.

The function of fats is similar to that of the carbohydrates. Fats, however are a more concentrated fuel, 1 lb. of fat being equal to about $2\frac{1}{4}$ lb. of carbohydrates. Fats can also be stored for future use in the fowl's body, a thing that cannot be done with carbohydrates.

PERCENTAGE OF FOOD PRINCIPLES, NUTRITIVE RATIO, AND MANURIAL VALUE
OF POULTRY FOODS

Food	Dry Matter Per Cent.	Ash or Mineral Matter Per Cent.	Protein Per Cent.	Carbohy- drates and Fats Per Cent.	Nutritive Ratio	Manurial Value per 100 Lb. (Dollars)*
<i>Whole-grain foods:</i>						
Flaxseed.....	90.8	4.3	20.6	82.3	1 to 4.0	.657
Beans.....	87.0	2.6	17.0	50.8	1 to 3.0	.541
Peas.....	90.0	2.6	16.8	53.4	1 to 3.3	.548
Hemp seed.....	87.8	4.3	16.3	96.9	1 to 5.9	
Canary seed.....	86.4	2.1	13.5	61.7	1 to 4.6	
Sunflower seed.....	92.5	2.6	12.1	85.8	1 to 7.1	.428
Wheat.....	90.0	1.8	10.2	73.0	1 to 7.2	.426
Rye.....	88.0	1.9	9.8	70.0	1 to 7.1	.329
Wheat screenings.....	88.4	2.9	9.8	55.9	1 to 5.7	.462
Oats.....	89.0	3.0	9.2	56.8	1 to 6.2	.378
Millet.....	86.0	3.3	8.9	52.2	1 to 5.9	.365
Barley.....	89.0	2.4	8.7	69.2	1 to 8.0	.288
Corn.....	89.0	1.5	7.9	76.4	1 to 9.7	.826
Buckwheat.....	87.0	2.0	7.7	53.3	1 to 6.9	.247
Kafir corn.....	84.8	1.5	7.8	63.2	1 to 8.1	
Broom corn.....	85.9	3.4	7.4	54.8	1 to 7.4	.244
Sorghum seed.....	87.2	2.1	7.0	59.1	1 to 8.4	.281
Rice.....	87.6	.4	4.8	72.9	1 to 15.2	.175
<i>Meals and hay:</i>						
Old-process oil meal.....	91.0	5.3	29.3	48.5	1 to 1.7	.960
Gluten meal.....	92.0	.8	25.8	65.6	1 to 2.5	.774
Buckwheat middlings.....	87.0	4.8	22.0	45.6	1 to 2.1	.256

Gruen feed.....	92.0	1.1	19.4	63.3	1 to 3.3	
Coconut-oil cake.....	86.0	4.7	16.4	64.8	1 to 4.0	
Wheat middlings.....	88.0	3.8	12.8	60.7	1 to 4.7	.471
Wheat bran.....	88.0	5.8	12.2	45.3	1 to 3.7	.618
Alfalfa hay.....	92.0	7.4	11.0	42.3	1 to 3.8	.431
Hominy chop.....	89.0	2.5	7.5	70.5	1 to 9.4	.316
Corn bran.....	90.9	1.2	7.4	70.1	1 to 9.5	.335
Red clover hay.....	85.0	6.2	6.2	39.6	1 to 6.4	.329
Oat hulls.....	90.6	6.7	1.3	41.5	1 to 31.9	.113
<i>Animal foods:</i>						
Meat scraps (lean).....	89.3	4.1	66.2	31.1	1 to 0.5	1.750
Meat scraps (fat).....	94.6	1.5	53.0	68.0	1 to 1.3	
Dried blood.....		4.7	52.3	5.6	1 to 0.1	2.128
Dried fish.....		39.2	44.1	23.2	1 to 0.5	1.772
Animal meal.....		19.5	32.0	23.0	1 to 0.7	
Cottage cheese.....	29.0	.8	21.0	6.6	1 to 0.3	
Fresh meat.....	26.4		20.5	7.9	1 to 0.4	
Fresh-cut bone.....		11.5	18.0	42.0	1 to 2.4	
Yolk of eggs.....	47.0	1.0	16.0	67.5	1 to 4.2	
White of eggs.....	16.2	1.2	12.0	4.5	1 to 0.4	
Buttermilk.....		.7	3.9	6.5	1 to 1.7	.088
Skim-milk.....		.7	2.9	5.9	1 to 2.0	.103
<i>Green foods:</i>						
Grass.....	24.7	2.0	3.5	15.5	1 to 4.4	
Red clover, green.....	29.0	2.1	2.9	16.4	1 to 5.7	.107
Cabbage.....	15.0	1.4	1.8	9.1	1 to 5.1	.082
Rape.....	14.0	2.0	1.5	8.6	1 to 5.7	
Mangel beets.....	13.0	1.1	1.1	5.6	1 to 5.1	.951
Turnips.....	9.5	.8	1.0	7.6	1 to 7.6	.050

*The v values are relative.

Analyses of Foods.—The preceding table gives the analyses, nutritive ratio, and manurial value of various poultry foods.

SEEDS AND THEIR BY-PRODUCTS

Foods the quality of which is unquestionably good are the most economical for poultry. Shriveled, immature, or imperfect grains do not contain the full amounts of digestible nutrients, and such grains are likely to be deficient in protein. When the best results are desired none except good, plump, mature grains are used. The same principle applies in selecting the by-products of grains.

The relative value of poultry foods can best be estimated when the food value of each is well understood. It is usually more profitable to buy the foods rich in protein than those lacking in this valuable principle.

WHEAT

Whole Wheat.—A grain of wheat is made up of an outer shell, an inner lining, and a food center, its structure in a general way resembling that of an egg. The shell of the wheat kernel is composed largely of crude fiber; the central part contains some protein, but consists mainly of starch. The protein, or gluten, of the wheat is the most valuable part of it, and no other grain will fill the place of wheat as a food for the production of lean meat and eggs by fowls. Wheat is rich in both protein and the fat-forming principles, but it is a better food for making blood, flesh, and feathers than for fattening purposes; hence, it is a better food for egg-producing hens than for those intended for the market. Wheat is commonly one of the several grains used in making up a ration for fowls. Although the best whole grain for hens, it does not form a perfect ration when fed alone.

Second grades of wheat can be purchased at a lower price than the higher grades. If they are sound and

have good feeding qualities, these second-grade wheats can be used to advantage; but if they are shriveled or blighted, they have little value. Burned, wet, musty, or otherwise damaged grains are not fit for feeding to poultry.

The accompanying table shows the digestibility of the various food principles found in wheat of good quality. Although about 20% of its dry matter is indigestible, wheat, on account of its palatability, is the best possible whole-grain food for fowls.

DIGESTIBLE MATTER IN WHEAT

Parts of Wheat	Per Cent. Digestible	Parts of Wheat	Per Cent. Digestible
Organic matter.....	81.86	Crude fiber.....	None
Protein.....	77.12	Carbohydrates.....	86.59
Fat.....	39.67		

Wheat Screenings.—The value of wheat screenings as a food depends on the quantity of weed seeds and other materials that are mixed with the wheat of inferior quality. Good wheat screenings have a food value equal to that of oats; screenings of poor quality have a food value that may be less than that of oat hulls or straw. Although fowls will eat a large portion of the weed seeds in screenings, many of them have no food value. Wheat screenings as a food for poultry are used in connection with an animal food and corn.

Wheat Bran.—The amount of gluten contained in wheat bran, which is a by-product in the manufacture of flour, determines its value as an egg-producing food. If the bran has the appearance of being kiln-dried, it probably contains so little digestible material that it is worthless as a food for hens. As dry bran free from gluten is practically all crude fiber, it is valuable only

as a bulky substance for distending the intestines so that concentrated foods may be digested.

Middlings and Shorts.—The terms middlings and shorts are applied to by-products of the manufacture of flour. Wheat middlings are made from the membrane that lies between the outer shell and the starchy interior of the wheat kernel; they contain some gluten, a substance composed largely of protein. Shorts as usually sold are made up of small, or ground, bran and wheat sweepings. Thirds, or fine shorts, are middlings of good quality. Middlings are worth more than bran and are much used in making dry-mash rations.

Flour.—When it can be cheaply obtained, the lower grade of dark flour is sometimes used for feeding to poultry. This flour is rich in protein and other food principles, and can be mixed with middlings and corn meal. The resulting mixture may then be baked like bread and fed to young or growing chicks. A small quantity of this flour mixed with mash forms a crumbly mass.

Whole Oats.—The determination of the value of whole oats by their appearance is exceedingly difficult. Good oats rank next to wheat as a poultry food, but the one objection to oats is that they vary widely in the proportion of hulls, or husks, which are indigestible. Some oats are two-fifths husks, which are of no value as food. The weight of oats varies from 25 to 50 lb. per bu. Light oats are unfit food for fowls; heavy oats with full, plump kernels are one of the very best. Hulled oats are preferable for feeding to poultry; heavy-weight clipped oats stand next in value; ground oats of the best quality are also an excellent food for poultry.

Oatmeal and Hulled Oats.—In the manufacture of both oatmeal and hulled oats, which have the same nutritive ratio, the hulls are removed; consequently, the food value of both oatmeal and hulled oats is greater than that of whole oats. Oats thus prepared are extensively used in making rations for young or growing

chicks. Whole oats have a nutritive ratio of 1 to 6; hulled oats and oatmeal, 1 to 4. Consequently, prepared oats are better than whole oats as food for young chicks and laying hens. Either hulled oats or oatmeal is one of the best single-grain rations for fowls.

Oat Hulls.—As a poultry food, oat hulls, apart from their value as manure, which is small, are worth no more than sawdust. Ground oat hulls are liberally used as an adulterant to lessen the cost of other foods in preparing poultry feeds, and the presence of much of this adulterant may so reduce the value of the feed as to make it useless.

CORN

Whole Corn.—The structure of the corn kernel is similar in a general way to that of the wheat grain. Corn is the grain that is ordinarily the most attractive to poultry. Some corn is almost a necessity for successful poultry feeding, but an all-corn ration is injurious because it is too fattening. Corn alone, however, will not fatten a fowl in the best way, nor will it produce a good yield of eggs. Corn is rich in carbohydrates and fats; it provides heat for the body, and oil and fat for the feathers, for the yolk of the egg, and for the flesh. Corn contains too little protein and ash for successful egg production, and to produce the best results is combined with other grains. A balanced ration is formed by the use of corn and some other grains and meat.

Corn Bran.—The outside of the grain, or the shell, from which corn bran is made, is removed from corn when it is made into food products for human beings. This shell is hard and dry and has almost no food value, being composed almost entirely of indigestible fiber and a little ash; and is, therefore, of no use in poultry rations.

Gluten Meals and Feeds.—Gluten, a by-product of corn starch manufacture, is sometimes sold as gluten meal, and is a very important food for dairy cows. Good gluten meal that does not contain corn hulls,

or other waste products is also useful as a part of the meal ration for poultry. Gluten meal is a concentrated food, rich in protein, nearly all of which is digestible. Not more than 10% of a ration should consist of this meal.

The germ of the corn is rarely sold separate from the other by-products. Like gluten meal, it should be fed sparingly to fowls.

Gluten feed, which is much more commonly sold than either gluten meal or the corn germs, is made by grinding the germs, hulls, and gluten together. Gluten feed, although not so rich in protein as either the gluten meal or corn germs, should not be fed too liberally to poultry.

Hominy Chop.—Hominy is made from the hard or flinty part of the corn. The hulls, corn germs, and some gluten left after the hominy is made, are ground into coarse meal and sold as hominy chop, which, if of good quality, is fully equal in value to corn meal as a poultry food. Like the value of all grain by-products, the value of hominy chop depends on its quality, and it should not contain too much crude fiber.

Corn Cobs.—The coarse meal made from corn cobs cannot be prepared in any way that fits it for food. It has about the same chemical composition as straw, and as food for poultry both corn cobs and straw are valueless.

MISCELLANEOUS GRAINS AND SEEDS

Kafir Corn.—Both Kafir corn, or dari, and broom corn belong to the sorghum family of plants. The fact that Kafir corn is used largely as food by people of Africa and in other countries is evidence of its nutritive value, Kafir corn being, in this respect, about equal to barley or buckwheat. Kafir-corn grains are very hard; tests made by feeding old, very dry grains to fowls show that many of them passed through the fowls without being broken up. The same grains resisted for a time an effort to soften them by boiling. When

broken into bits, however, the small pieces could be eaten and digested by young chicks. In some localities where bugs and worms are plentiful, the entire grain ration for the summer months is Kafir corn, a plentiful supply of insect food with this kind of grain making a nearly balanced ration. Kafir corn can be used with safety in the ration for full-grown fowls, and if broken into small pieces, for chicks as well.

Broom Corn.—The seed of broom corn as a food for poultry is about equal in value to sunflower seed. Broom corn is fed sparingly; a ration containing more than 10% of this grain cannot be fed with safety to fowls. In order to avoid fermentation and mildew, the heads of the grain are spread out and kept in a dry place. Ptomaine poisoning is liable to be produced by the eating of moldy grain or seed of any kind.

Rye.—The use of rye as a food for poultry should be avoided; fowls do not relish it and bad results may come from its use.

Barley.—The grains of barley, if plump and of good quality, contain almost as much protein as oats, more than corn, and more of the carbohydrates than oats but not so much as corn. Good barley is about 15% hulls; poor barley may have a much larger percentage of hulls, and the grains themselves may be so shriveled as to be valueless as food. Good barley meal is useful for forming a part of a meal ration for fattening fowls. It is one of the best meals for this purpose; but the ordinary barley meals are likely to be made of a mixture of barley and waste products, which tend to deprive the meal of its feeding value.

Buckwheat.—Fowls have to acquire a liking for buckwheat; they are not naturally fond of it, and as the hull, which forms a large percentage of this grain, is indigestible, buckwheat is not good as a single-grain ration. Buckwheat whitens the flesh and improves its flavor when fed liberally to fowls. The yolks of eggs from hens fed freely on buckwheat are light in color. Although a small quantity of buckwheat may be used

as a part of an all-grain ration, it is not classed as a desirable grain for fowls.

Buckwheat Middlings.—The hulls of buckwheat have no feeding value, but in some localities they are used as litter in buildings and brooders. Buckwheat middlings are superior to wheat bran and wheat middlings as a food for fowls, and this fact brings into the market buckwheat bran, which is largely broken hulls mixed with buckwheat middlings. Although the floury middlings of buckwheat are fit for poultry food, the bran of this grain is useless for this purpose.

Peas.—Although fowls relish pea vines, they must acquire a liking for the peas themselves, which are very good food. The field pea, or Canada pea, as it is sometimes called, is largely used as food for pigeons, and on the whole is probably the best pea for other kinds of poultry. Low-priced, broken peas, if cooked, can at times be used to advantage. When they have been thoroughly softened by boiling, wheat bran is added to them to make a crumbly mass; a little flour put with the bran will help to make the mass stick together. A mixture prepared in this way is greedily devoured by hens, and is an excellent egg-producing ration. Pea meal is a concentrated food that should be sparingly used. Peas or pea meal added to a fattening ration improve the quality of the lean meat.

Beans.—As a food for poultry, beans are more nutritious than peas. Bean vines are not so well liked as the pea vines, nor will the fowls eat beans as long as they have other food before them. Soybeans contain much protein and ash; because of this fact they are valuable food for fowls. Beans should be boiled to a soft mush and mixed with corn meal and bran; this preparation makes an egg-producing ration. If sufficient corn meal is added, a fat-forming ration that will produce a good quality of table meat is made. Fowls are naturally attracted to a mixture of this kind. Like other cooked foods, boiled beans may be fed to fowls while warm, but never while hot.

Rice.—Rice is a fat-forming food that is little used for poultry. Small or broken rice, however, may be used in chick feed to advantage. Boiled rice is a good food for bantams because it produces so little bone and size; it satisfies hunger but does not produce growth to any extent. It is an expensive food for fowls.

Millet.—The seed of the foxtail millet is a rich grain that should not be fed liberally to poultry. When thrown into litter, the small, bright-colored seeds attract the fowls. A ration made up entirely of millet will destroy young chicks and injure old fowls. This seed is used to a limited extent in chick feeds, and also in scratching foods for hens. Millet is a fattening food and when hard, dry millet seed is liberally fed, it may clog the intestines or pass through them undigested.

Sorghum Seed.—The food value of the seed from sugar-producing sorghum is about equal to that of the seed of broom corn, but sorghum seed is more fattening than the broom-corn seed, and contains a little less protein than that seed. Sorghum plants that make good green food for fowls are grown from sorghum seed sown broadcast or drilled into the ground.

Sunflower Seed.—Sunflower seed has a nutritive ratio of 1 to 7, about the same as wheat; but the digestibility of sunflower seed has not yet been accurately determined. It is likely that the larger part of sunflower seeds are indigestible. The kernels have a pleasant flavor and contain considerable fat, but when dry and shriveled their food value is small. Fresh, plump sunflower seeds are used to advantage by sparingly feeding them to fowls in molt; if these seeds are liberally fed, the digestive organs of fowls soon become clogged with indigestible fiber.

Flaxseed.—Of all the grains and seeds fed to poultry, flaxseed is the richest in oil and protein. Its use is seldom necessary, because equal benefit can be derived by using by-products of seeds that are much less expensive. Flaxseed is a laxative, but contains so much gluten that it may clog the digestive organs.

Linseed Meal.—There are two kinds of linseed meal—old process and new process. The latter contains less protein and is more fattening than the former. There is very little old-process meal made at the present time. Linseed meal contains the feather-forming elements to a large extent and is valuable during molt; it can be cautiously fed at all times. Fowls do not favor it as a food; it is laxative, concentrated, and contains so much gluten that it will clog the crop if used too liberally. The quantity of linseed meal used should not exceed 5% of the entire ration.

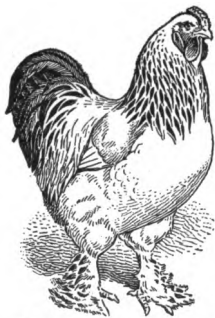

LIGHT BRAHMA MALE

Cottonseed Meal.—Even when fed sparingly, cottonseed meal is not relished by fowls. Neither cottonseed nor any of its products should ever be fed to fowls, as these foods act as irritants to the digestive organs, and if fed liberally cause death.

Peanut Meal.—Meal made from peanuts after the oil has been extracted is a good food for poultry. It is a palatable food and can be used in small quantities with other fattening meals. An ounce and a half of peanut meal has about the same food value as 1 oz. of the best meat scrap. There is so little of this meal that it cannot often be used as food for poultry.

Hemp Seed.—Hemp seed contains more fat and less fiber than sunflower seed; for this reason, hemp seed is more easily digested and gives better results than sunflower seed. Hemp seed, which is a stimulating, fat-forming food, is fed in small quantities and only to fowls that are slow to molt. A small quantity of this seed is also fed to exhibition fowls during cold weather to improve the gloss on their plumage. Hemp seed is too expensive for general use.

Canary Seed.—The best known balanced ration for cage birds is canary seed; young chicks also enjoy a little of this seed, on which they will thrive when they do not do well on other grains. All waste canary seed should be fed to chicks, but this feed is too costly to use except in an emergency or to save the waste from cage birds.

Rape Seed.—German rape seed, or bird-seed rape, is a better food than millet seed for young chicks. It is a fattening food, rich in protein, and dark or chestnut brown in color. Rape-seed grains are smaller than millet seeds. For ailing or weakly chicks, rape seed is boiled for 5 min., turned into a fine, funnel-shaped sieve, and left to drain over night. A small quantity of this food is given in the morning and evening. Only the true German rape seed is fit for this use.

VEGETABLES

Mangels.—Of all the vegetables and roots that are fed to poultry as substitutes for green foods, mangels are the best; they are fine-flavored, sweet, and nutritious, and impart these qualities to the meat and eggs of the fowls. No objectionable flavors are introduced into either the flesh or the eggs as a result of feeding mangels liberally. Mangels are rank growers, keep well throughout the winter if protected from frost, are easily fed, and are freely eaten by fowls.

Beets.—There are many kinds of beets, all of which are eaten freely by poultry. If too many raw beets are fed, however, the bowels of the fowls may become so loose that diarrhea will result, especially if the use of beets is long continued. Raw beets should be sparingly fed, but if they are cooked they make a valuable addition to a ration.

Turnips.—As a poultry food, turnips are not so desirable as beets. If turnips are fed raw, they taint the flavor of the eggs and do not improve the meat

of market poultry. The rutabaga is the best variety of turnip for poultry, but even this turnip will taint the eggs if fed to any extent. Turnips, parsnips, and carrots, when boiled to a pulp and mixed with the mash feeds, make good rations for all kinds of poultry. A very little salt should be put in the water in which the vegetables are boiled. Too much salt will kill poultry; fowls require much less salt than men.

Potatoes.—When they are plentiful and cheap, potatoes are used as poultry food; 5 lb. of potatoes is about equal in feeding value to 1 lb. of corn meal. Potatoes fed to laying hens are thoroughly boiled, drained, and mixed with wheat bran, middlings, and ground oats; the same mixture will do for growing chicks, but if it is to be used for fattening purposes some corn meal is added to this ration. Meal that is made from small potatoes is used as a fattening food; this meal contains all the solid food of the potato and only a small percentage of the original moisture. The meal is an easily digested food, and it is used where potatoes are more plentiful than grain. Raw potatoes are not fit food for poultry.

Onions.—Although onions are wholesome food for all kinds of fowls, their flavor is imparted to the eggs and meat of the fowls that eat them; for this reason onions should not be used when their flavor will prove objectionable. Turnips, onions, and potatoes may be boiled together and used in mash food for all kinds of poultry without harm, provided none of the mixture is fed for 2 wk. before killing the fowls for market or selling their eggs for food. All of these vegetables can be safely used for hens when their eggs are to be used for hatching and not for food.

Cabbage.—Although not the best thing for them, cabbage is a favorite food of fowls, and is often quite liberally fed. Cabbages are laxative, especially when they have been frozen. They also impart an odor to eggs that detracts from their quality. If cabbages are permitted to freeze and are carelessly fed they may reduce the egg yield materially, and may also cause

so much looseness of the bowels of the fowls that their health will be injured. Kale and Swiss chard can be used in the same way as cabbages.

GREEN FOODS

Green, or growing, plants are valuable as food for poultry on account of the natural juices they contain. The tender blades of grass and other forage plants impart new life to fowls that feed on them in the spring. Chicks can be grown and fowls sustained without green food, but the difference between those that have it in abundance and those that do not is so marked that all question of its value is removed.

Green food is at its best when gathered by the fowls from the field where it grows, but good results may be obtained by substituting clover hay or other dried forage for the green portion of the ration. This practice is necessary where the fowls cannot range extensively and whenever there is no available green food owing to climatic or other conditions. Fowls must have a constant supply of green food.

The green food consumed by fowls or chicks should not be considered as a regular portion of the nutritive ration, but rather as a supplement to the grain and animal food. The composition and nutritive ratio of green food is given in the accompanying table.

Vegetable Tops.—Poultry relish the tops of vegetables as green food. Trimmings from vegetables and the waste from fruit, cabbage, and roots, cut into small pieces, boiled to a pulp, and mixed into a mash of meal, make an excellent food for all kinds of fowls, both old and young.

Grass.—Nearly everywhere grass of many kinds grows naturally or is cultivated for feeding, grazing, and hay making, and none of the green foods is better for poultry. Where grass is naturally abundant, a supply of green food is always at hand during the growing season. But green food for winter use must be grown

**COMPOSITION AND NUTRITIVE RATIO
OF GREEN FOODS**

Food	Dry Matter Per Cent.	Digestible Nutrients			Nutri- tive Ratio
		Protein Per Cent.	Carbo- hy- drates Per Cent.	Fat Per Cent.	
Alfalfa.....	20.0	3.7	7.3	.6	1 : 2.4
Alfilerilla.....	20.0	2.1	8.5	.7	1 : 4.8
Barley.....	21.0	1.9	10.2	.4	1 : 5.8
Red clover.....	29.2	2.9	14.8	.7	1 : 5.7
Crimson clover....	19.3	2.2	9.3	.4	1 : 4.6
Corn.....	20.7	1.0	11.6	.4	1 : 12.5
Cowpeas.....	16.4	1.7	8.8	.3	1 : 5.6
Blue grass.....	34.9	2.7	17.8	.7	1 : 7.2
Hungarian grass....	28.9	1.9	15.6	.4	1 : 8.7
Orchard grass.....	27.0	1.9	15.9	.6	1 : 9.1
Oats.....	37.8	2.4	17.9	.9	1 : 8.3
Rye.....	23.4	2.5	14.1	.4	1 : 6.0
Rape.....	14.3	2.2	8.6	.3	1 : 4.2
Red top.....	34.7	2.6	21.2	.6	1 : 8.7
Soybeans.....	28.5	2.8	11.8	.6	1 : 4.7
Timothy.....	38.4	2.1	21.2	.6	1 : 10.8
Kafir corn.....	27.0	.8	13.8	.4	1 : 18.4
Lettuce.....	4.1	1.0	2.7	.8	1 : 4.5
Artichokes.....	20.0	2.0	16.8	.2	1 : 8.7
Beets.....	15.7	1.6	11.9	.1	1 : 7.6
Beet leaves.....	11.3	1.7	4.6	.1	1 : 2.8
Cabbage.....	15.3	1.8	8.2	.4	1 : 5.1
Carrots.....	11.4	.8	7.8	.2	1 : 10.4
Mangels.....	9.1	1.1	5.4	.1	1 : 5.1
Parsnips.....	11.7	1.6	11.2	.2	1 : 7.3
Potatoes.....	21.1	.9	16.3	.1	1 : 18.3
Pumpkins.....	9.1	1.0	5.8	.3	1 : 6.5
Rutabagas.....	13.0	1.2	7.5	.2	1 : 6.7
Sweet potatoes....	19.7	1.5	24.7	.4	1 : 17.1
Turnips.....	9.5	1.0	7.2	.2	1 : 7.7
Apples.....	15.9	.4	14.2	.3	1 : 37.3
Onions.....	12.4	1.4	9.4	.5	1 : 7.5

and stored, and in some places the supply for the entire year must be grown.

Clippings of grass from the lawn are also good food for poultry that is confined in yards; or, if dried and stored, these clippings will be good for winter use. Either fresh or dry, they are valuable as litter for the floor of the brooder or brooder house.

Fodder Corn.—Corn that is sown broadcast or drilled in rows produces tender, green stalks called fodder corn, which is relished by fowls that are confined; it is not preferred by fowls having their freedom, nor should it be fed after it has passed beyond a succulent or juicy condition.

Alfalfa and Clover.—The tender leaves of all the clovers and of alfalfa are in much demand by fowls. They probably prefer alfalfa, or lucerne, to clover. After it has become well established, alfalfa will continue to grow for many years and will produce heavier yields of green forage and hay than any of the clovers. To raise alfalfa successfully, the soil must be adapted to the needs of the plant, and in many localities clover can be raised more easily than alfalfa.

During winter months, clover hay can be used as a substitute for green food. Hay made from Red clover is most frequently used for this purpose, although hay made from any of the clover plants is good winter food for fowls. It may be used as litter on the floor, from which the fowls will help themselves, or the hay may be cut into small pieces and placed in a box for the fowls to work over. They eat all the leaves of clover hay. Bright, clean, early-cut hay is preferable to a dark hay made from cured plants. Ground clover and clover meal may also be used as food for poultry.

Hay made from alfalfa is extensively used for poultry, and it may, like clover, be cut into pieces or ground into a fine meal before feeding. All forms of alfalfa are freely eaten both by old and young fowls, and alfalfa is not equaled by any other hay as a substitute for green food for fowls. Meadow hay may

be ground and mixed with alfalfa meal, but alfalfa is best fed without mixture or adulteration.

Miscellaneous Green Crops for Winter Feeding.—In addition to those already mentioned, many other green crops are grown for winter feeding. A mixture of oats, peas, rape, and clover planted on the same ground and cut while green makes a good forage crop for fowls. First, sow 3 bu. oats and 2 bu. peas per acre and harrow into the ground; then, seed over the oats and peas with a mixture of 6 qt. clover seed and 1 qt. German rape seed.

ANIMAL FOODS

MEAT AND MEAT PRODUCTS

Marked success in producing eggs and in growing poultry for the market cannot be obtained without the use of some animal food.

Insects and worms form an important part of the food of wild birds and of domestic fowls whenever they are permitted to range.

Lean Meat.—Meat is an acceptable substitute for insects and worms. Lean meat is especially useful in the feeding of laying hens, for by using this food much protein may be added to the ration without increasing its bulk or using concentrated foods that impair digestion. The carcasses of horses and cows are composed mainly of lean meat and are used as poultry food.

Meat Scrap.—There are two kinds of meat scrap, fat and lean. The latter kind contains twice as much protein as carbohydrates, while the former contains more fat than protein and very little ash. The best lean-meat scrap should be selected for laying hens; the more protein and the less fat the scrap contains, the better it is for the hens. Fat-meat scraps and fat or tallow are used in fattening special grades of table poultry.

Animal Meal.—One of the numerous by-products of the slaughter houses is animal meal. The feeding value

of animal meal is higher than that of cut green bone; but better results are obtained from the use of cut green bone than from animal meal, because the former contains a larger percentage of ash than of protein—presumably because the meal is made from both bone and meat. Good meat meal is rich in protein but contains less ash than animal meal, and can only be used sparingly in making an egg-producing ration. Because of its cost and richness in protein, meat meal is used only when good meat scrap cannot be obtained.

Dried Blood.—Dried blood and blood meal are sometimes used to supply protein in foods for poultry. These blood products are concentrated foods and a small quantity of either mixed with other foods will make a narrow ration. Dried blood and blood meal are not generally economical or profitable foods for poultry.

Cut Green Bone.—The food commonly called cut green bone is made by cutting fresh bones into small pieces by means of a bone mill. Being fresh meat, bone, and fat, its composition closely resembles that of bugs and worms, the natural food of fowls. About $\frac{1}{2}$ oz. of cut green bone per day for each fowl, mixed with wheat bran, will make a balanced ration well suited to fowls.

Tainted Meat.—Tainted meat that is not fit for human food should not be fed to fowls. The taint of such food may sometimes be removed by boiling it in water containing baking soda, in which case the meat can be safely fed to fowls.

Bone Meal.—Bone meal consists of bones of animals cleaned of all meat, fat, and marrow, and reduced to meal. It is used to supply any deficiency of lime, ash, or bone-forming material that exists in the ration. Bone meal can be fed to young chicks to produce a strong growth of bone. The particles in this meal vary in size from those that are very small to those of the size of whole wheat or even corn; the largest sizes are not desirable for poultry food.

Fish.—Fish that are handled for their oil are reduced in presses until little of their flesh remains. The bone and other residue are then ground into a meal. This fish meal and dried fish are sometimes fed to poultry. Fish products are liable to transmit a disagreeable flavor to the eggs or meat, and for this reason are not desirable.

MILK

Milk is a valuable poultry food, more valuable than its commercial analysis indicates. Nothing excels warm milk direct from the cow as the first ration for chicks. The use of whole milk as a chicken feed, however, will rarely prove profitable, for even when carefully handled it is not worth more than 2c. per qt. for this purpose. The most profitable method of feeding milk to fowls is to use it in moistening mash feeds.

Some persons prefer sweet milk for poultry, but G. A. C. Wyllie, of the British Dairy Institute, Reading, England, says that sour milk has been found to give better results, as the acid produced by the bacteria present causes more rapid action. He states: "Soured milk also prevents scouring, and makes the food easier digested. The acid formed from the milk sugar also prevents sickness and stimulates the appetite. It keeps the digestive organs in proper activity, which saves feeding so much green food. When fed to all kinds of poultry it produces a fine white flesh, due to the amount of phosphates, with extra good flavor. It is without doubt one of the best foods we have both for young and old stock, and is becoming more popular every day. I may say it also increases the egg supply and hastens the molt."

Skim-milk, sour milk, and buttermilk, may be improved for feeding purposes by scalding; but care should be taken not to boil, as boiling destroys the value and palatability. The whey of milk is of no value as a poultry feed. In the accompanying table is shown the composition and nutritive ratio of whole milk and of various milk products.

COMPOSITION AND NUTRITIVE RATIOS OF MILK AND MILK PRODUCTS

Food	Water Per Cent.	Ash Per Cent.	Protein Per Cent.	Carbo- hydrates Per Cent.	Fat Per Cent.	Nutritive Ratio
Whole milk.....	87.2	.7	3.6	4.9	3.7	1 : 2.4
Skim-milk.....	90.6	.7	3.3	5.3	.1	1 : 1.9
Sour milk.....	90.6	.7	3.3	5.3	.1	1 : 1.9
Cottage cheese (milk curds)	72.0	1.8	20.9	4.3	1.0	1 : .3
Buttermilk.....	90.3	.7	4.0	4.5	.5	1 : 1.4
Whey.....	93.4	.5	.8	5.0	.3	1 : 7.0

MINERAL MATTER

Grit.—The food eaten by fowls goes first into the crop, where it is softened by water; it then passes into the gizzard, and by the action of small sharp stones, or grit, is there ground into a pasty mass. The best grit is sharp, irregular pieces of hard limestone about the size of corn kernels.

Mineral matter is necessary for the good health of the fowls and for egg-shell-forming material. A deficiency of this in the regular ration may be supplied by grit, limestone, plaster, broken oyster shells, or shells of any kind. Granulated bone and bone meal serve the purpose fairly well, but the lime in shells is more quickly dissolved by the action of grit and gizzard, and hence is better than the bone.

Charcoal. — Charcoal is one of the necessities of poultry feeding and should be kept constantly before poultry; it assists digestion, sweetens the crop, gizzard, and intestines, and prevents ailments of the

digestive tract. The charcoal, which should be broken into small pieces, should be supplied with the oyster shells and grit.

Salt.—The use of salt in poultry food is not a necessity; but when a forcing ration is fed to fowls either to produce broilers, to fatten fowls, or to produce eggs, some salt may be used to assist digestion; 8 oz. of salt to 100 lb. of meal is enough to use; much more than this will injure the digestion of grown fowls, and it is positively unsafe to feed more to young chicks.

POISONOUS FOODS

Fowls sometimes die from ptomaine poisoning. For this reason putrid meat, spoiled grain, and other fermented or spoiled foods should not be fed. Foods that are otherwise wholesome may be made unwholesome if exposed to dampness, due to the development of molds.

Excessive quantities of salt, salt meat, or the brine from which the meat has been removed, salt fish, salt from ice-cream freezers, and in fact, salt of any kind consumed in large quantities is very destructive to poultry.

Solutions of sulphate of iron or of sulphuric acid, carelessly used, are very destructive to poultry.

Decayed vegetables or fruits, fermenting waste, waste from cider mills or canning factories, and slops from distilleries are not suitable for feeding to laying hens, because they flavor the eggs. Tainted meat eaten by a fowl will also influence the flavor of eggs.

Moldy bread is detrimental to poultry. It may be freed from mold by toasting or baking it dry and hard, but when so prepared it is not fit food for chicks under 6 wk. old.

FEEDING OF FOWLS

In poultry feeding it is necessary not only to provide fowls with a ration properly balanced in the food elements, but the ration must also be of a character most suitable to the digestive organs of the fowls. In addition to this the fowls must be forced to take sufficient exercise so that their bodily functions will demand a plentiful supply of food, be in a condition to secure the best results from the food that is eaten, and be able to eliminate readily all waste materials.

When fowls take sufficient exercise, the only secret of keeping their digestive organs in the best condition will be found in feeding them a plentiful supply of coarse feed like bran, or some of the succulent green foods, such as cut clover, cut grasses, vegetables, or fruits. These foods will distend the intestines and aid in distributing the concentrated foods that are necessary for upbuilding the tissues of the body and for egg production. To induce fowls to take considerable exercise, a certain part of their grain food should be scattered in the litter of the houses and on the ground of the ranges so that they will be compelled to scratch to get it.

When kept actively exercising, fowls will not eat more than their digestive organs will be able to handle easily, provided fattening foods are not fed in excess and the ration is well balanced for egg production.

Despite the necessity of a certain quantity of coarse food to regulate their digestive organs, fowls must be fed as little indigestible matter as is consistent with the maintenance of their health and of a well-balanced ration. For instance, hens cannot thrive on a ration made up entirely of even the best grade of oats, and when oats are fed that are three-fourths husks, all the hens can possibly stuff themselves with will do little more than barely sustain life and will produce but few eggs. Chick feed and feed for full-grown fowls

that is largely indigestible will seriously injure those that eat it. It is possible for chicks and full-grown fowls to dwindle away with their crops stuffed full of indigestible material. The fact that a fowl's crop is distended with food is no proof that it has been well fed. Hence, the only actual proof of the value of any particular feed for fowls lies in the results that are obtained from it.

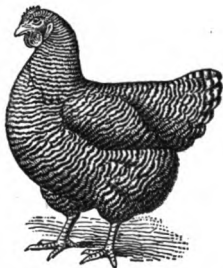

**BARRED PLYMOUTH ROCK
FEMALE**

As a part of the daily ration, water is equal in importance to grain. Without water, the food would not be softened in the crop and digestion would not go on. Blood, eggs, and meat are all largely water; even the bones and muscles are dependent on moisture for growth. Pure water is an absolute necessity for poultry; if the drinking water is tainted, putrid, or

contaminated with germs, disease is sure to follow its use. A gallon of fresh water each day is not too much for 2 doz. hens. A plentiful supply of pure water from which they can help themselves must be constantly kept within reach of fowls.

The composition of fowls and fresh eggs is shown in the accompanying table. The large percentage of water in them emphasizes the necessity for a plentiful supply of water.

Cost of Protein in Poultry Foods.—As protein is the most expensive food principle that has to be bought, and as there is a variation of several hundred per cent. between the cost of protein in some foods as compared with others, care should be taken in the purchase of foods for the supply of this valuable food principle. The accompanying table will aid in selecting feeds for their protein value. The feeds are arranged in the

COMPOSITION OF FOWL AND EGG

	Water Per Cent.	Ash Per Cent.	Protein Per Cent.	Fat Per Cent.
Hen.....	55.8	3.8	21.6	17.0
Pullet.....	55.4	3.4	21.2	18.0
Capon.....	41.6	3.7	19.4	33.9
Fresh egg.....	65.7	12.2	11.4	8.9

COST OF PROTEIN IN POULTRY FOODS

Food	Price per Ton Dollars	Protein	
		Pounds per Ton	Price per Pound Cents
Skim-milk.....	4	66	6.0
Rice.....	30	106	28.3
Corn.....	30	156	19.2
Oats.....	30	184	16.3
Wheat.....	30	184	16.3
Broken crackers.....	26	190	13.7
Mixed feed.....	21	192	10.9
Barley.....	25	192	13.0
Rye.....	30	198	15.1
Rice bran.....	16	214	7.5
Wheat bran.....	21	224	9.3
Wheat shorts.....	22	244	9.0
Wheat middlings.....	27	244	11.0
Wheat, shrunken.....	29	264	11.0
Alfalfa hay.....	11	274	4.0
Alfalfa meal.....	22	274	8.0
Coconut-oil-cake meal....	22	328	6.7
Beans.....		400	
Fresh meat.....		418	
Cottage cheese.....		518	
Linseed-oil-cake meal....	27	522	5.2
Gluten meal.....	30	680	4.4
Cottonseed meal.....	30	822	3.6
Meat meal.....	60	1,080	5.6
Dried blood.....	60	1,040	5.8

order of the quantity of protein they contain per ton. It will be seen that this factor does not fix the price of the feed, as rice at the same price as gluten feed

WEIGHT OF POULTRY FOODS PER QUART

Food	Weight Pounds
Alfalfa meal.....	1.0
Barley, whole.....	1.5
Barley meal.....	1.1
Beans.....	1.9
Beef.....	1.5
Buckwheat.....	1.3
Corn, whole.....	1.7
Corn meal.....	1.5
Corn bran.....	.9
Corn and oat food.....	.7
Cottonseed meal.....	1.5
Gluten feed.....	1.3
Gluten meal.....	1.7
Hemp seed.....	1.4
Hominy chop.....	1.1
Kafir corn.....	1.7
Linseed meal, new process.....	.9
Linseed meal, old process.....	1.1
Millet.....	1.6
Oats, whole.....	1.0
Oats, ground.....	.7
Peas.....	1.9
Rice.....	1.7
Rye, whole.....	1.7
Rye, ground.....	1.5
Sunflower seed.....	1.4
Salt.....	2.5
Shorts.....	.6
Wheat, whole.....	1.9
Wheat, ground.....	1.7
Wheat bran.....	.5
Wheat middlings (standard).....	.8
Wheat middlings (flour).....	1.2

contains less than one-sixth as much protein as gluten feed. In selecting poultry feeds, however, price is not the only consideration. Due regard must be paid

to the character of the feed. Coconut-oil-cake meal, and linseed-oil-cake meal can be purchased at a price that makes the cost of the protein low, but it would not be feasible to obtain a large part of the protein for a ration from these feeds.

Weight of Poultry Foods per Quart.—In the mixing of rations for poultry the weights of poultry foods per quart as given in the preceding table are useful.

FEEDING OF YOUNG CHICKS

No food is given to young chicks for the first 48 hr., but grit of some kind is supplied to clean out their digestive organs. Beginning with the third day, they may have stale bread moistened with sweet milk and pressed until nearly dry. For the next 2 or 3 da. a mixture of stale bread crumbs and fine oatmeal makes a good ration, and is better fed in small quantities at frequent intervals.

For chicks that are a week or more old, a simple ration can be made of 4 parts, by weight, of cracked

FEEDING STANDARDS FOR YOUNG CHICKS

Age of Chick	Quantity per 100 Lb. of Live Weight of Chicks					Fuel Value Calories	Nutritive Ratio
	Dry Matter Pounds	Protein Pounds	Fat Pounds	Carbohy- drates Pounds	Ash Pounds		
First 2 wk. . .	10.1	2.0	.4	7.2	.5	18,800	1 to 4.1
2 to 4 wk. . .	9.6	2.2	.5	6.2	.7	17,730	1 to 3.4
4 to 6 wk. . .	8.6	2.0	.4	5.6	.6	15,640	1 to 3.3
6 to 8 wk. . .	7.4	1.6	.4	4.9	.5	13,780	1 to 3.7
8 to 10 wk. . .	6.4	1.2	.3	4.4	.5	11,680	1 to 4.3
10 to 12 wk. . .	5.4	1.0	.3	3.7	.4	10,000	1 to 4.4

corn, 2 parts of broken wheat, 2 parts of oatmeal, and 2 parts of granulated meat scrap. The corn should be broken into small pieces and the meat scrap must be of good quality, rich in protein, and of small size; meat scrap that contains fat is not fit to use in this ration. After the chicks are 6 wk. old, a ration made of cracked corn, whole wheat, hulled oats, and meat scrap can be used. In addition to the grain and meat ration, grit, green food, broken sea shells, or bone meal are necessary for young chicks. All food fed to chicks should be in small particles to avoid disorders in the crop and digestive organs.

The accompanying table gives the feeding standards for young chicks.

MIXTURES FOR CHICK FOOD

<i>Food</i>	<i>Quarts</i>	<i>Food</i>	<i>Quarts</i>
	(a)		(b)
Shelled corn	16	Millet seed5
Wheat	8	Cracked Kafir corn.	1
Hulled oats	4	Cracked wheat	2
Pearl barley	3	Cracked wheat	2
Millet seed5	Canary seed	1
		Oatmeal	1
		Finely granulated	
		meat5
	(c)		(d)
Fine siftings from		Fine broken corn...	35
cracked corn	40	Cracked Kafir corn.	6
Cracked wheat	30	Cracked wheat	40
Oatmeal	10	Hulled oats	30
Millet seed	3	Broken peas	5
Granulated meat ...	7	Animal charcoal ...	5
		Millet seed	5
		Meat scrap	10
	(e)		(f)
Cracked corn	50	Cracked corn	200
Whole wheat	50	Whole wheat	300
Clipped oats	30	Barley	200
Barley	10	Clipped oats	100
		Screenings	200
		Buckwheat	100

Mixing of Chick Foods.—The term chick food is used to describe mixtures made from food materials that are used for feeding chicks. Many kinds are manufactured and sold commercially; if they are of good quality, their use may be convenient and safe. Chick food can be made of numerous kinds of grains and seeds. Any of the mixtures given in the accompanying table form suitable chick foods. After the grains in (a) have been ground and mixed, 4 qt. of beef scraps should be added to the mixture; (a) is adapted to chicks having the free range of a farm; (b) is for bantams or chicks of tender constitution; (c) and (d) are for those partly or wholly confined; (e) and (f) are grain mixtures suitable for half-grown chicks on the range.

Feeding Schedule for Chicks.—Chicks thrive best if fed five times a day until they are 6 wk. old, after which age they may be fed four times daily; and at 8 wk. of age, three meals a day are sufficient. The following schedule may be observed in feeding five meals a day:

First Meal.—Soon after daylight. Bread crumbs, seed, or small grain, according to age.

Second Meal.—Eight or nine o'clock. Egg food, mash feed, or chick feed, according to age.

Third Meal.—Noon. Small grains or chick feed, scattered into chaff or dry litter of some kind.

Fourth Meal.—Two o'clock. Either egg food, mash feed, bread softened with milk, or johnny cake.

Fifth Meal.—Four o'clock. A full meal of small grain or chick feed, scattered in the chaff or litter.

The small grains and chick feed should be scattered in dry chaff or cut straw. Fine or short-cut alfalfa or clover hay makes good litter; sand, sawdust, or chips of wood are undesirable litter for chicks. Clean, dry earth may also be safely used for litter.

FEEDING OF LAYING HENS

A ration for laying hens is not suitable unless it contains enough of the food principles to maintain the bodily growth and to supply enough material for the production of eggs; that is, protein, fats, carbohydrates, ash, and water must be plentifully supplied and in the proper proportions.

Quantity of Food Required by One Hen in a Year. The figures for the quantity of food required by one hen in a year given in the accompanying table were derived from careful records of the food eaten by several hundred hens in a year. They show a total average of about 4.86 oz., or a little less than 4 oz. of grain and meal, and about $\frac{9}{10}$ oz. of other material per day for each hen. Another test of 4,800 hens shows a food consumption of 3.96 oz. of grain per day, besides green food and grit.

QUANTITY OF FOOD REQUIRED BY ONE HEN IN A YEAR

Food	Quantity Pounds
Grain of all kinds and meal.....	90.0
Oyster shell and bone.....	6.4
Grit.....	2.0
Charcoal.....	2.4
Green food and clover hay.....	10.0
Total.....	110.8

Cost of Feeding One Hundred Hens for a Month.

The following figures show the cost of feeding 100 Barred Plymouth Rock hens per month. The figures are taken from the record of Mrs. Fred G. Orne, of Orleans, Vt., and are based on the present high prices of grain.

Clover	\$1.12
Wheat	2.28
Oats	1.52
Corn	3.84
Dry mash	3.11
Beef scrap73
Grit, shells, turnips50
Straw53

Total.....\$13.63

The total cost of feed for the 100 hens for the 12 mo. of the year was \$163.56, which gives a cost per hen per year of \$1.63½. During the year the hens produced an average of 130 eggs, or 10¹⁰/₁₂ doz. These were sold for an average of 30c. per doz., making the value of the eggs produced \$3.25 per hen. This gives a profit of \$1.61½ per hen over the feeding cost.

Feeding Schedule for Laying Hens.—The following feeding schedule adapted to the needs of a flock of 500 Single-Comb White Leghorns has been used successfully on a large commercial poultry farm for a number of years. The same feeding schedule may be adapted to any conditions or to any number of fowls by proportionate increases or decreases in the quantities of each item fed.

FEEDING SCHEDULE FOR 500 FOWLS

7 A. M. *Wet Mash.*—About 31 qt. (fed in troughs in house) made up as follows:

<i>Ingredients</i>	<i>Quarts</i>
Steamed clover	5
Wheat middlings	5
Corn meal	7½
Bran	7½
Meat scrap	3½
Linseed meal	1
Charcoal	¾
Oyster shell	¾

This mash is moistened with sufficient water to make it sticky, not thin.

9 A. M. *Scratch Feed*.—About 8 qt. (fed in yards, except on rainy days, when it is fed in the litter of the houses). This is barley one day and hulled oats the next.

11 A. M. *Green Feed*.—About 16 qt. or $\frac{1}{2}$ bu. (fed in either the yard or house according to the weather) made up of any succulent food, such as beets, beet tops, turnips, turnip tops, cabbage, lettuce, or any plant that is bulky enough so that the fowls can get a foothold on it while eating. Vegetables and similar plants need not be chopped up, but lawn grass, rye, clover, or anything of this nature it is advisable to cut into $\frac{1}{4}$ -in. lengths.

1 P. M. *Scratch Feed*.—About 8 qt. (fed in the same way as in the morning scratch feed) made up of equal quantities of wheat and barley, or of wheat and hulled oats. If hulled oats are used in the morning scratch feed, barley should be used in the afternoon, and vice versa.

5 P. M. (or 1 hr. before sundown). *Grain Feed*.—About 30 qt. or all the fowls will eat and a little left over (fed in troughs in houses). On rainy days when the fowls are confined to the house it is well to scatter this feed in the litter in order to provide the necessary exercise. The feed is made up of a mixture of cracked corn and wheat. The proportions of corn and wheat vary with the seasons. In May, June, July, and Aug. the proportion is two-thirds wheat and one-third cracked corn. As the weather becomes cooler the quantity of corn should be increased and the quantity of wheat decreased. For instance, if the temperature is likely to drop as low as 40° F. during the night, the

ration should be one-half cracked corn and one-half wheat. If it is likely to drop to 32° F., the ration should be two-thirds cracked corn and one-third wheat. On exceptionally cold days, when the thermometer is down to zero and below, the entire ration should be cracked corn.

AT ALL HOURS. *Water.*—A plentiful supply and fresh, either in drinking fountains or in some other convenient way.

Dry Mash.—Fed in hoppers in the houses, and made up the same as the wet mash, except that the steamed clover and linseed meal are left out.

Meat Scrap.—Fed from wall hoppers inside the houses.

Grit, Oyster Shells, and Charcoal.—Fed from wall hoppers inside of the house.

Cornell Rations for Laying Hens.—The following whole-grain mixture is fed morning and afternoon in a straw litter:

DURING WINTER			
<i>Food</i>	<i>Pounds</i>	<i>Food</i>	<i>Quarts</i>
Wheat	60	Wheat	32
Corn	60	Corn	36
Oats	30	Oats	30
Buckwheat	30	Buckwheat	20

DURING SUMMER

Wheat	60	Wheat	32
Corn	60	Corn	36
Oats	30	Oats	30

The following mash is fed dry in a hopper during winter and summer, the hopper being kept open during the afternoon only.

<i>Food</i>	<i>Pounds</i>	<i>Food</i>	<i>Quarts</i>
Corn meal	60	Corn meal	57
Wheat middlings .	60	Wheat middlings	71
Wheat bran	30	Wheat bran	57
Alfalfa meal	10	Alfalfa meal	20
Oil meal	10	Oil meal	8
Meat scrap	50	Meat scrap	43
Salt	1	Salt	½

The fowls should eat about half as much mash by weight as whole grain. Regulate the proportion of grain and ground feed by giving a light feeding of grain in the morning and about all they will consume at the afternoon feeding (in time to find grain before dark). In the case of pullets or fowls in heavy laying, restrict both night and morning feeding to induce heavy eating of dry mash, especially in the case of hens. This ration should be supplemented with beets, cabbage, sprouted oats, green clover, or other succulent food, unless running on grass-covered range. Grit, cracked oyster shell, and charcoal should be accessible at all times. Green food should not be fed in a frozen condition. All feed and litter used should be strictly sweet, clean, and free from mustiness, mold, or decay. Serious losses frequently occur from disease, due to the fowls taking into their bodies, through their intestinal tract or lungs, the spores of the fungus causing molds.

Rations for Sixteen Hens for 30 Da.—The accompanying table contains twelve desirable rations for feeding to hens. The quantities given in each division are sufficient for feeding 16 hens for 30 da., and provide about 4 oz. of food daily for each hen. The whole grain in all these rations is fed by hand; the meal and meat in each is mixed together and fed either as a wet or a dry mash. Rations (i) and (j) are double, or two-part, rations. One-half of the daily ration is fed from each; the two answer for 60 da. Rations (a), (b), (c), and (d) are best suited to a promiscuous lot of fowls ranging in age from 6 mo. to several years. Rations (e), (f), (g), and (h), being largely composed of concentrated foods, are best suited for laying hens. Rations (i) and (j) are for laying hens that have free range and are able to pick up insects enough to supply their demand for animal food. Rations (i) and (k) are fed in hoppers as dry mash. The molasses feed used should be of good quality. Ration (l) consists of meals, wheat, and milk; the meals

30-DAY RATIONS FOR SIXTEEN HENS

<i>Food</i>	<i>Pounds</i>	<i>Food</i>	<i>Pounds</i>
(a)		(b)	
Corn	50	Corn	50
Oats or barley	24	Oats or barley ..	24
Wheat bran	10	Wheat bran	10
Middlings	5	Flour middlings..	4
Corn meal	25	Corn meal	28
Meat scrap	8	Animal meal	7
Cut clover	10	Cut clover	10
(c)		(d)	
Corn	50	Corn	50
Wheat	25	Wheat	25
Corn meal	28	Corn meal	25
Flour middlings ...	2	Wheat bran	10
Hominy chop	10	Middlings	5
Meat scrap	7	Alfalfa meal	4
Cut clover	10	Meat scrap	7
(e)		(f)	
Alfalfa hay or meal	18	Alfalfa	18
Wheat bran	10	Wheat bran	14
Middlings	30	Middlings	17
Coconut-oil-cake meal	10	Linseed-oil-cake meal	6
Meat meal	6	Blood meal	4
Wheat	60	Barley or oats....	25
(g)		(h)	
Corn meal	24	Wheat shorts	18
Wheat bran	18	Corn meal	25
Alfalfa meal	10	Blood meal	5
Blood meal	3	Alfalfa meal	5
Meat meal	6	Cottage cheese ..	12
Oats or barley....	30	Wheat	60
Wheat	40	(i)	
(i)		(j)	
Wheat bran	40	Wheat	60
Middlings	20	Cracked corn	30
Corn meal	20	Oats	15
Alfalfa meal	40	Barley	15
(k)		(l)	
Corn meal	10	Middlings	30
Molasses feed	20	Wheat bran	24
Middlings	40	Meat meal	6
Wheat bran	30	Skim-milk	90
Meat scrap	10	Wheat	60
Clover hay	10		

should be moistened with the milk. In the use of all rations where meals only are mentioned, a daily ration for each hen should consist of 2 oz. of dry meal, fed wet or dry, and an equal quantity of whole grain.

None of these rations furnish sufficient mineral matter for egg formation and for the other demands of nature. Grit, limestone, oyster shell, or some similar material must be supplied in addition.

Feeding of Farm Flocks.—Farm flocks, to be profitable, must have a ration suitable for the production of both eggs and good table meat. No error in feeding farm flocks is more common or more disastrous than that of giving too much fat-forming food. An all-green ration renders the hens excessively fat, sometimes induces apoplexy, and causes the production of but few eggs. A grain ration for farm flocks may be composed of grains in the following proportions, by weight:

<i>Food</i>	<i>Parts</i>
Cracked corn	20
Wheat	40
Oats	15

Cracked corn is preferable because it is small, and, like wheat and oats, when cast into litter must be sought for by the fowls. During the winter all grain should be thrown into dry chaff or litter of some kind in order to keep the hens busy hunting for it.

During the winter months the hens on the farm should have a noonday feed of warm mash, the mixture being composed, by weight, as follows:

<i>Food</i>	<i>Parts</i>
Corn meal	40
Meat	30
Short-cut alfalfa or clover hay.....	30
Oyster shell	2
Grit	1
Charcoal	1

The meat and hay should be cut into small pieces and boiled to a pulp, and before cooling the mass should be mixed with enough meal to make a dry, crumbly mass. This should be fed cool in troughs.

FEEDING OF FOWLS DURING MOLT

Fowls that are molting should have good nourishing food in order properly to nourish their bodies while they are under the unusual strain of replenishing the plumage. Foods rich in fat and protein are best for the purpose; hence, during molting, a mash that contains a large proportion of linseed-oil-cake meal and meat is particularly desirable.

In the morning, molting fowls should have a moderate meal composed of equal parts, by weight, of cracked corn and whole wheat.

At noon they should have all they will eat of mash composed, by measure, of the following:

<i>Food</i>	<i>Parts</i>
Wheat bran	4
Wheat middlings	3
Ground oats	3
Meat scrap	4
Corn meal	3
Linseed-oil-cake meal	4
Low-grade flour	1
Alfalfa meal	2

During the first week of the molting period this ration should contain only 1 part each of meat scrap and linseed-oil-cake meal; after the first week the quantities of these materials should be increased at the rate of $\frac{1}{2}$ part per day every other day until the quantities given in the table have been reached. In case such a ration proves to be too laxative, the quantity of meat and linseed meal is lessened and $\frac{1}{2}$ part of fine charcoal is added to the mixture.

At night all the corn meal and wheat they will eat is fed to the fowls.

This method of feeding should be continued until the molt is complete, after which a laying ration is fed to the hens.

Attempts to force molting are occasionally successful, but the advantages derived from this practice do not usually pay for the trouble caused. To force molting, fowls are confined in a small house for about 3 wk., are fed very sparingly, but all the fresh water they will drink is given to them. The quantity of food given should be gradually reduced until at the end of the first week they are receiving only about one-third of the usual food supply. During the second and third weeks not more than 1 oz. of grain, or one-fourth of a ration, should be fed per day to each fowl. This partial starvation will reduce flesh and fat and dry the oil from the feathers, causing them to drop very readily. At the end of the third week the fowls should be liberated and the food supply gradually increased. By the end of the fourth week they should receive full rations.

FEEDING OF POULTRY FOR MARKET

Fowls intended for market are commonly fattened, or finished, according to one of three systems: Range fattening, yard fattening, and crate fattening. As employed on many farms, these systems may be more accurately termed stages of the fattening process, for the reason that often no particular one of the systems is rigidly adhered to on any one farm. For instance, some fowls are simply range-fattened before killing; in other cases the fattening process is carried further and the fowls are more completely fattened by a more or less protracted period of feeding in yards or in crates. The degree of success attained in fattening depends on two things, namely, the quantity of fattening food that is fed to the fowls and the amount of exercise they are allowed to take.

Range fattening consists simply in giving the fowls a quantity of fattening food for a few weeks to

increase their weight to some extent before they are killed for market. In *yard fattening*, fattening foods are given to fowls as in range fattening, but, as their exercise is materially restricted, there is a greater gain in weight, and the quality of the flesh is also improved by the softening of the muscles. The very best grades of market poultry, however, are finished by *crate fattening*. By confining fowls in crates, or coops, exercise is almost wholly prevented. All the fattening food that they will consume is given to them, and, as a final step, forced feeding is sometimes resorted to.

Feeding of Fowls in Fattening Yards.—Fowls confined in fattening yards should be fed three times a day and should have all the food they will eat up clean. The food should consist of mash, cracked corn, wheat, and some animal food. The mash should be made of 2 parts of finely ground oats or barley from which the hulls have been removed, 2 parts of corn meal, and 1 part of wheat middlings, all mixed with hot milk or boiling water. Milk is preferred to water for mixing, and the mash should always be fed while moist and warm.

A full meal of the mash is fed in the morning and at noon. At night the fowls should have a grain mixture consisting of equal parts of cracked corn, wheat, and hulled oats. No meat will be needed during the first week if the mash is mixed with milk. After the first week, 5% of the mash should consist of meat, and some fat can also be added to it. The meat must always be sweet and clean and free from bad odors. Green food is not needed. Water and grit must be kept before the fowls continually.

Feeding of Fowls in Crates.—In crate fattening, the methods of feeding most generally followed are: trough feeding, hand stuffing, funnel feeding, and machine cramming. The last three are methods of forced feeding, but machine cramming is the only one of importance to the poultryman who is producing a large number of well-fattened fowls.

In *trough feeding*, the fowls are fed three times, whereas in hand stuffing, funnel feeding, and machine cramming, all three of which are finishing processes, the fowls are fed twice a day.

When first placed in the crates, the fowls should remain without food for a day; then they are fed in troughs as long as they retain an appetite for the food; after this point is reached, they are usually finished off by machine cramming.

One ration recommended for trough feeding is composed by measure, not by weight, as follows:

<i>Food</i>	<i>Parts</i>
Ground oats	2
Ground barley	1
Ground corn	1

Hand stuffing is very seldom followed at the present time, particularly in America. It consists of pushing boluses, or small rounded masses of food, into the crops of fowls that are to be quickly fattened. Boluses 1 in. long and about $\frac{1}{2}$ in. thick are moistened with milk and worked into the crop of the fowl by inserting them in the throat or gullet of the fowl and then running the thumb and forefinger down the outside of the throat. This work must be done gently to avoid choking the fowl.

Funnel feeding consists in pouring liquid food or gruel of the consistency of thick cream through a funnel into the crop of the fowl. In employing this method of feeding, great care must be taken to avoid choking or otherwise injuring the fowl. Specially made funnels with the ends turned over and so shaped as to lessen this danger may be purchased. The funnel is gently pushed down the throat or gullet of the fowl into the mouth of the crop. The different positions of the tip of the funnel as it passes down through the gullet must be followed with the point of the finger on the outside of the neck. After the tip of the funnel has entered the crop, the gruel is poured into the

funnel with a spoon. As soon as the crop is full the funnel is removed.

Machine cramming is the most approved process of finishing fowls for market after they have been partly fattened in crates by trough feeding. It is performed by means of a device known as a cramming machine. One of these machines is shown in the accompanying illustration; it is supplied with a reservoir from which the liquid food used passes into the force pump. In



using this machine, the operator places his foot on the treadle and forces it down, thus pulling the pump rod attached to a bumper inside the force pump and forcing the food through an outlet into the crop of the fowl. The quantity of food given to each fowl is regulated by a setscrew.

The fattening rations best suited for feeding by the cramming machine, but which may also be used in other methods of crate feeding, are given in the

accompanying table. All the meals used should be ground as fine as wheat flour; coarse meals, fiber, or husks will not answer for any form of crate feeding. The rations (a), (b), (c), and (d) are all suited for use when yellow-meated fowls are desired; mixture (e) will produce white-meated fowls, and mixture (f) is for use in the cramming machine during the last week of feeding. The formula best suited for any given locality should be selected and used. In general, fattening rations for poultry should have a nutritive ratio of from 1 to 4 or more. In all cases the parts in the table are calculated by measurement and not by weight.

FATTENING RATIONS

<i>Food</i>	(a)	<i>Parts</i>	<i>Food</i>	(b)	<i>Parts</i>
Ground oats		1	Ground oats		4
Ground barley		1	Ground peas		1
Ground corn		2	Ground corn		4
	(c)			(d)	
Ground oats		2	Ground corn		2
Ground corn		2	Ground buck-		
Clover meal		1	wheat		2
Blood meal		1	Ground oats		1
	(e)			(f)	
Ground oats		4	Ground oats		5
Ground barley		1	Ground barley ..		1
Ground buckwheat.		1	1 oz. of tallow to		
			each 4 fowls		

FEEDING OF TURKEYS

Poults should have nourishing food in small particles so that they will be able to digest it properly. No sour or fermented food, chopped green bone, raw meat, or large quantities of millet seed, cottage cheese, or wet or sloppy foods should ever be fed to poults. Poults require plenty of grit and fresh water.

A ration of stale bread crumbs and a ration made up of equal parts of stale bread crumbs, finely chopped hard-boiled eggs, and dandelion leaves, fed alternately, is a good method of feeding poults.

Turkeys on a range plentifully supplied with natural foods that they like will need much less feeding than turkeys that are compelled to live on a range where the natural food supply is scanty. Turkeys should have plenty of corn, wheat, and some oats, the quantities and proportions varying with the character of the food on their range.

FEEDING OF GUINEA FOWLS

Like poults, young guinea fowls should be fed on finely divided foods, and water should be given to them in very shallow vessels to prevent the young birds from drowning in them. Grit and plenty of fresh water should be supplied.

A ration suitable for young guinea fowls is composed, by measure, as follows:

<i>Food</i>	<i>Parts</i>
Very fine oatmeal	2
Finely cracked wheat	2
Rape seed	1
Canary seed	1
Ant's eggs, or very small particles of cooked meat, or finely chopped hard-boiled eggs.....	1

Guinea fowls for market can be fattened on milk curds, steamed hulled oats, and warm mash. If these feeds are not available, guinea fowls can be satisfactorily fattened on a ration composed of equal parts of ground oats, barley meal, and table scraps.

FEEDING OF PHEASANTS

The first food of young pheasants should be composed, by measure, as follows:

<i>Food</i>	<i>Parts</i>
Very small bread crumbs.....	1
Canary seed	1
Fine grit	1
Very fine corn grits.....	1

If the pheasants are 2 da. old, about 10% of cooked lean meat may be added. Stale bread softened in sweet milk and a custard of eggs and milk put together with enough stale bread crumbs to soak up the greater part of the moisture, are good foods for young pheasants. A certain quantity of meal worms may be fed to mature pheasants, although a ration composed, by measure, as follows, is preferable:

<i>Food</i>	<i>Parts</i>
Finely chopped hard-boiled eggs.....	1
Crushed hemp seed	1
Stale bread crumbs.....	1
Oatmeal	1
Finely chopped cooked lean meat.....	½
Finely chopped green food should also be fed.	

FEEDING OF DUCKS

During the fall, in addition to green food, ducks should have twice a day as much as they will eat of a mash consisting, by measure, of the following:

<i>Food</i>	<i>Parts</i>
Corn meal	4
Wheat bran	12
Low-grade wheat flour.....	1
Fine grit	¼

A small quantity of meat scrap may be added to this ration if desired.

During the winter, ducks should have a liberal supply of chopped green feed. Twice a day they should have all they will eat of a mash feed composed, by measure, as follows:

<i>Food</i>	<i>Parts</i>
Wheat bran	5
Corn meal	6
Low-grade wheat flour.....	1

A small quantity of meat scrap may be added to this ration if desired.

A suitable feed for laying ducks, when they have an ample supply of green food, is a mash food composed, by measure, as follows:

<i>Food</i>	<i>Parts</i>
Wheat bran	3
Ground oats	3
Corn meal	3
Low-grade wheat flour.....	1
Meat scrap	1

Many rations are used for fattening broiler ducks for market. A good one to use for the 10 da. or 2 wk. previous to killing is composed, by measure, as follows:

<i>Food</i>	<i>Parts</i>
Corn meal	10
Wheat bran	4
Wheat middlings	4
Meat scrap	3
Low-grade wheat flour.....	1
Green feed	2
Coarse sand	1

Ducklings intended for breeders are fed on a ration composed, by measure, as follows:

<i>Food</i>	<i>Parts</i>
Wheat bran	10
Wheat middlings	6
Corn meal	3
Low-grade wheat flour.....	1
Meat scrap	1
Sand	1

This is mixed into a crumbly state by the addition of milk or water and fed three times daily. In some cases, instead of wheat bran 6 parts of bran and 4 parts of ground oats are substituted

Another ration for ducklings intended for breeders is composed, by measure, as follows:

<i>Food</i>	<i>Parts</i>
Corn meal	6
Wheat bran	6
Wheat middlings	6
Meat scrap	1

During the laying season ducks will eat about 1 pt. of food each per day. Their food should always consist of at least 2 or 3% of grit, ground oyster shells, or some similar material.

FEEDING OF GEESE

A simple ration for goslings is composed, by measure, of the following:

<i>Food</i>	<i>Parts</i>
Corn meal	1
Wheat bran	1
Ground oats	1
Table scraps	1

Geese are by nature grazing birds, and the greater part of their living consists of green food. Because of their lack of a crop, geese should be fed on ground corn in the form of a slightly warmed mash. During the winter, in addition to green food, the matured geese should have once a day all they will eat of a ration composed, by measure, as follows:

<i>Food</i>	<i>Parts</i>
Corn meal	3
Wheat bran	3
Ground oats	3

During the winter this same ration with 4 parts of steamed clover added is suitable.

The following rations are suitable for fattening geese for market.

They should be fed liberally three times a day. The morning and noon feeds should consist, by measure, of the following:

<i>Food</i>	<i>Parts</i>
Corn meal	6
Ground oats	6
Meat scrap	1

This mixture should be slightly moistened and mixed until it assumes a crumbly state. During the last 10 da. of feeding the quantity of meat in the ration should be doubled.

In the evening the geese should be fed all they will eat of a ration composed, by measure, as follows:

<i>Food</i>	<i>Parts</i>
Cracked corn boiled until soft.....	1
Corn meal	1
Wheat middlings	1

FEEDING OF WILD WATER FOWLS

Where wild water fowls have the freedom of a large enough pasture, they will graze the greater part of their living, but it is always advisable to keep near at hand covered hoppers where the fowls may help themselves at will. For mature ducks and geese, the hopper should be kept filled with a dry mixture composed, by measure, as follows:

<i>Food</i>	<i>Parts</i>
Ground oats	1
Cracked corn	1
Wheat bran	1

FEEDING OF PIGEONS

The grains most suitable for feeding to pigeons are wheat, corn, buckwheat, barley, peas, vetch seed, hulled oats, millet, rice, hemp seed, and canary seed. No large quantity of buckwheat, barley, hulled oats, or Kafir corn, should be fed to pigeons, because these grains contain a large percentage of crude fiber.

Pigeons that are not feeding their young may consume as little as 2 oz. of grain each, per day, but those feeding their young will require perhaps as much as 4 oz. per day.

A suitable ration for pigeons is composed, by measure, as follows:

<i>Food</i>	<i>Parts</i>
Corn	2
Wheat	1
Peas	1

During the fall and when the pigeons are molting, a good ration for them is composed, by measure, as follows:

<i>Food</i>	<i>Parts</i>
Corn	4
Wheat	4
Peas	4
Millet	2
Vetch seed	1
Flaxseed	1
Hemp seed	$\frac{1}{4}$

A ration for the hand feeding of pigeons, that is, for scattering on the floor of the house, is composed, by measure, as follows:

<i>Food</i>	<i>Parts</i>
Canada peas	3
Cracked corn	1
Wheat	1
Kafir corn	1

INCUBATION

NATURAL INCUBATION

In poultry, the reproductive process is accomplished in two stages. The egg is first produced, developed, fertilized within the body of the hen, and laid. Then the egg is subjected to a certain temperature (100° F. or a little higher) for about 21 da., during which time the embryo develops and hatches out of the shell as a chick. The process of developing the embryo within the egg by means of heat is called *incubation*. When this is carried on by a hen, it is known as natural incubation; when incubation is accomplished by means of a machine, oven, or other device, it is known as artificial incubation. Man has little control over the reproductive process in its first stage except insofar as the selection of the breeders is concerned; in the second stage, however, if artificial incubation is practiced, he can, by his methods of conducting the process, greatly influence the development and future well-being of the chick.

Fertilization of the Egg.—In order that eggs shall hatch, the hen that lays them must have been mated with the male. The actual fertilization of the egg probably takes place as the yolk enters the oviduct. In the process of fertilization the germ from the male comes in contact with the germ cell, or blastoderm, and causes it to develop, provided that it is exposed to the right temperature. Hatchable eggs are those that are fertilized and have vitality enough to insure the production of a living chick.

Eggs are usually fertile up to and including those laid the ninth day after the hens are separated from the males, and fertilization is impossible after the sexes have been separated for 12 da. or more. Eggs may safely be counted as fertile after the males have been with the hens for 9 da. or more.

The eggs of all kinds of fowls are more apt to be fertile during the spring and early summer than at any other time. Fertility begins to decline with the commencement of molting, and during the fall and winter the production of fertile eggs is at the minimum. The average production occurs in Jan. or soon after.

Period of Vitality in Eggs.—Fresh-laid eggs hatch in fewer hours than eggs that are kept 2 wk. or longer before the process of incubation begins. After eggs are 4 wk. old it is not safe to rely on their vitality being sufficient to produce chicks that will grow to maturity, although in some cases eggs 3 mo. old have produced chicks that grew to maturity. Fresh-laid eggs from fowls of all kinds hatch in fewer hours than eggs that are kept for any length of time.

Eggs for hatching that are moved or turned about each day can be safely kept for 14 da.

Average Period of Incubation of Eggs.—The average period of incubation of eggs is as follows:

	<i>Days</i>
Fowls, medium and large-sized breeds....	21
Bantams and other small breeds.....	19 to 20
Ducks	28
Muscovy duck	35
Muscovy duck crossed with Pekin or other drake	32
Geese	28
Turkeys	27 to 29
Guinea fowls	28 to 30
Pheasants	24 to 25
Peafowls	27 to 29
Pigeons	17
Swans	35 to 40
Ostriches	40 to 42

Selection of the Sitting Hen.—Cochin, Orpington, Plymouth Rock, Rhode Island Red, and Wyandotte hens are the best for hatching purposes. The quiet hen that will sit contented on the nest until her work

is finished and will then go forth and care for her brood is the kind to be depended on both for raising utility fowls and fowls for exhibition.

The most unsatisfactory hen for hatching is the nervous hen that fusses and fights all who move about her; that will spring quickly from the nest when any one approaches her, thus breaking her eggs and disturbing those left in the nest. A good motherly hen that will rear two broods in one season is the kind to be depended on.

Nests for Sitting Hens.—Nests for sitting hens must be large enough to prevent the eggs from being crowded or piled on one another. Nests carelessly made assure bad results; the eggs roll out and are broken or chilled. The depth of a poorly made nest is not sufficient to protect the eggs from below nor will it aid the hen by holding the warmth about the eggs. A comfortable nest can be made in a box laid on its side and filled with fine hay or soft straw. A nest of this kind will do when the hen is by herself and is safely shielded from other hens that might disturb her while sitting. Nests in which hens are sitting must be protected against intrusion from other hens, for the sitting hens must have quiet and must be undisturbed while on the eggs. If the hens are disturbed they become nervous, move about, and break the eggs.

Number and Arrangement of Eggs.—A setting of eggs should consist of an odd number, because an odd number fits better in the nest than does an even number. Thirteen eggs are generally considered as a setting. The eggs should be uniform in size, for if some are small and others large the body of the hen will not come close to the smaller ones and the temperature of the eggs will not be uniform. Eggs of irregular size are unfit for incubation. Eggs of this kind seldom, if ever, produce perfect chicks. Eggs set under hens gain a smooth gloss from contact with the body of the hen. By this means, as the process of incubation advances, the pores of the eggshell are closed.

ARTIFICIAL INCUBATION

During recent years there has been a large increase of market poultry, resulting from the practice of artificial incubation. The incubator operator can control production by artificial means, but with hens a desire to hatch cannot be hastened. The artificial methods of hatching and rearing chicks bring alike to the farmer and to the small grower the choice of the day of production and of the number of chicks produced.

The results obtained from artificial incubation depend primarily on the vitality of the eggs; but the handling of the incubator, surrounding influences, and the general efficiency of the incubator itself are other conditions of fundamental importance. The vitality of eggs

depends on the constitutional vigor of the fowls that produce them; superior vigor must come through several generations of strong and healthy fowls. It follows therefore that, in order to have embryo chicks of marked vitality, eggs must be used that come from strong, vigorous, well-bred fowls.



WHITE PLYMOUTH ROCK
MALE

The *per cent. fertility* is an expression that is frequently misleading. More than 90% of the eggs may be fertile and yet no living chicks may come from them, because the germ is so lacking in vitality that

it dies before incubation is completed. The *per cent. fertility* is increased by proper feeding and the vigor of both male and female is also increased, but there is a pronounced difference between fertility and vitality. The former may exist to a marked degree even though

the vitality of the germs or the egg be lacking, but the latter obviously cannot be present without the former. Chicks that are not strong and of abundant vitality when hatched should never be raised for breeders, but such fowls may be used for market poultry.

There is a marked difference between the production of fowls for exhibition or for beauty and the production of those fitted for egg yielding and for table meat. Where exhibition fowls are desired, the producing stock must be yarded to avoid the mixing of breeds or varieties. This is necessary only during the breeding season. At other times the old and young stock may have free range. Where egg producers and market poultry are desired, it is best to give the breeding stock all possible liberty. It is best to keep only one variety, and the flock should have free range if possible.

Relative Efficiency of Incubators and Hens.—The efficiency of hens and incubators has been compared in many localities. These comparisons show the results gained from hens set in many kinds of nests under average conditions on the farm, on the town lot, and with the fancier who keeps a few hens. The average per cent. of chicks obtained from both hens and incubators is shown in the accompanying table.

COMPARATIVE EFFICIENCY OF INCUBATORS AND HENS

	Number of Eggs Set	Per Cent. of Eggs Tested Out	Per Cent. of Chicks Dead in Shell	Per Cent. Hatched of Total Eggs Set	Per Cent. of Chicks Dead at 4 Wks. of Age	Live Chicks at 4 Wks. in Per Cent. of the Eggs Set	Number of Hatches
Hens.....	809	12.9	5.3	77.3	17.1	49.3	71
Incubators...	5,978	19.2	15.0	45.2	24.1	37.7	68

The records of artificial incubation are derived from experiments with different makes of incubators.

The hatch from hens ranged as high as 83.3% and as low as 50%, and that of the incubator from 77.1% to 32.5%.

Selection of Eggs for Incubation.—Eggs for hatching in an incubator should all be of one kind, size, and color; for only when eggs of such character are incubated together can uniform hatching be secured.

Eggs from Leghorns and Brahmas do not hatch well if both are together in the same incubator, for the eggs of the Leghorns usually hatch during the twentieth day, and the hatching of the Brahma eggs may be delayed to the end of the twenty-first day. If eggs from Leghorns, Plymouth Rocks, Wyandottes, and Brahmas are all together in the one incubator the hatch is irregular. Eggs but 1 da. old hatch a day sooner than eggs that are 2 wk. old. Leghorn eggs placed in an incubator on the day they are laid may hatch in 480 hr.; eggs of Asiatic fowls placed in the same incubator when 2 wk. old may not hatch for 516 hr., a difference in time that makes poor results inevitable if the eggs of both breeds are incubated together. The eggs of ducks and of chickens cannot be successfully hatched together in the same incubator, nor do the eggs of any two or more kinds of fowls hatch well if placed together in the same incubator or under the same hen.

If the eggs are of uniform size, the temperatures of all are equal or nearly so; if large and small eggs are in the same machine the temperature may not be the same in all.

Eggs with white shells hatch in fewer hours than do the dark-shelled eggs, for white shells are thinner and transmit heat more freely to the germ within. Under the same conditions, eggs with white shells will have larger air cells than those with heavier shells.

Only smooth and well-formed eggs should be used; eggs with uneven surface, bad form, rough shells, or

mixed colors should be discarded, as well as eggs that are abnormally large or small.

Care of Eggs for Hatching.—The best hatch is obtained from eggs placed in the incubator the same day on which they are laid. Eggs keep in prime condition for hatching up to the tenth day; if 2 wk. old they are safe for incubation; but if older than this they seldom hatch well, although some eggs that have been kept a month will hatch. Eggs keep best in a uniform temperature of about 55° F. in an atmosphere free from oil and other bad odors. The vitality of eggs that are exposed for any length of time to a temperature below 40° F. is impaired.

Eggs for hatching are shifted at least every other day so that the yolks will not settle to one side, stick to the shell, and thus destroy the germ. Preferably, the eggs should be stored small end down, either in a regular packing crate or any suitable receptacle.

Eggs for hatching are injured if they are washed; washing removes the natural glaze from the shell, and such eggs do not hatch well. Though not advisable to hatch dirty eggs, such eggs hatch better in soiled condition than they would if washed.

INCUBATORS

An incubator is an apparatus by means of which eggs may be artificially kept at the proper temperature for hatching. Many different styles and sizes of incubators are now in use, some of them being adapted for all sizes of eggs from those of the bantam to those of an ostrich. Incubators range in size from those the capacity of which is limited to a few dozen eggs to those that are capable of incubating many thousand eggs. The machines most commonly used have capacities that range from 5 to 30 doz. hen's eggs or a smaller number of any eggs that are larger than hen's eggs.

Though many different types of incubators are made, with but few exceptions in outward appearance they resemble the one shown in Fig. 1.

The essential parts of an incubator consist of a heating apparatus that is controlled by a regulator, and an egg chamber that can be held at the required temperature. Incubators are also supplied with thermometers and means of ventilation.

In the various incubators heat is brought into contact with the eggs either by diffusion or radiation. In *diffusion incubators*, hot air is evenly distributed through-

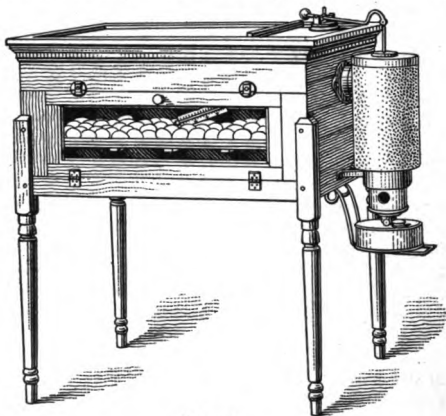

FIG. 1

out the egg chamber. In *radiation incubators*, the heat is radiated from pipes or radiators that are heated either by hot air or by hot water. A large part of the incubators in use are of the diffusion type, in which the air is heated by an oil lamp. In these machines the heated air passes directly into the egg chamber and throughout the interior of the machine. The eggs in the tray are thus surrounded with air at the required temperature. Incubators in which the heat is both radiated and diffused are also used. The more evenly the egg

chamber is warmed the greater will be the success in hatching.

The most satisfactory source of heat for incubators of all kinds is that obtained from oil lamps. Some incubators are heated by circulating hot water. Such incubators require particular care and attention, and their efficiency depends on the proper circulation of the water, the distribution of the pipes, and the lasting qualities of the entire heating system. Illuminating gas, electricity, and alcohol lamps are also used to some extent as sources of heat for incubators.

Incubator manufacturers prefer *thermometers* specially made to suit each kind of machine. There is usually a reason for such preference, and the thermometer recommended by the manufacturers should be favored. If this instrument cannot be obtained, the best that is made must be selected. Incubator thermometers are scaled from 90° F. to 110° F., and are marked *low* at 100° F. and *high* at 105° F., and the scale is crossed at 103° F. by an arrow or a heavy line. It is thus easy to make an accurate reading between the low and the high marks, provided the thermometer is correctly graduated.

Before being used, incubator thermometers are tested in the following manner: An instrument known to be correct is stirred about in warm water until the degree of heat is 105° F. or a little higher. Other thermometers are then held in the same hand with the one known to be correct and all are stirred about in the water so that the reading of all may be taken under like conditions. Any instruments that fail to mark the temperature correctly are rejected. It is best to test all thermometers in use at least once a season.

The printed directions that come with each incubator, giving instructions for its operation, also tell where the thermometer is to be placed in the machine, and to secure the best results such directions should be followed to the letter. The thermometer is usually placed in or near the center of the egg tray.

MANAGEMENT OF INCUBATORS

Incubators are managed so as to duplicate as nearly as possible the conditions existing under the hen in natural incubation. Heat, moisture, and ventilation are the main factors to watch.

Temperatures Necessary for Incubation.—When fertile eggs are exposed to a temperature of 100° F., or a little higher, the germ cell begins to grow; if this degree of heat is long continued the formation of a definite embryo follows, from which, in the case of hen's eggs kept constantly in a uniform temperature of 103° F. for 21 da., living chicks result. The temperature under sitting hens varies from 95° F. to 105° F. The most satisfactory results are obtained from a temperature ranging from 102° F. to 103° F. The average temperature at the lower side where the egg rests in the nest is about 98° F.; at the center of the egg it is about 101° F., although at the surface or top of the egg the temperature registers about 103° F. Eggs hatch best in an incubator at a temperature of 103° F., but they hatch fairly well in a temperature that varies from 101° F. to 103½° F.; and they may hatch if the temperature goes as low as 99° F. and as high as 106° F. Under the influence of low or irregular temperature, the hatch is delayed and the number of chicks obtained is a matter of uncertainty.

The heat under sitting hens varies fully as much as is permissible with incubators. A regular temperature that does not go below 102° F., nor above 103° F., is normal for the incubation period, except at the time of turning or cooling of the eggs. If the heat goes below normal, the hatch is delayed; if it goes above normal, the hatch is hastened; as a consequence of either of these conditions the eggs may be destroyed.

A regulator, or *thermostat*, is used to control the temperature in the egg chamber of an incubator. This is properly adjusted before eggs are placed in the machine.

Moisture in Incubators.—During incubation a part of the water in an egg is evaporated, and as the moisture content of the eggs grows less, the air cell becomes larger. This is indicated by the size of the air cell. The air cells differ under hens and in incubators in the same room; they are not alike under different hens, and they differ under the same hens and in the same machines. The greater part of the moisture in an egg disappears as the hatching period approaches, and consequently the air cell becomes larger in size and acts as a cushion, or filler, that prevents the embryo from flattening out inside of the egg. The normal size of air cell at different stages of incubation is shown in Fig. 2, in which the numbered lines refer to the size of the cell as seen on the fifth, tenth, fifteenth, and nineteenth days. An egg loses about 8 gr. of weight per day during the first 18 da. of incubation, the loss being due mainly to evaporation. As this loss occurs, the shell linings, or the inner and outer membranes, separate. This separation usually occurs at the large end of the egg, where the air cell is located.

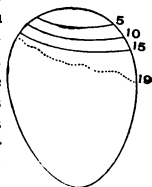

FIG. 2

Notwithstanding the fact that the air cell is normally located at the larger end of the egg, other air cells may form on the side of eggs that are not turned for several days prior to incubation or during the incubation period.

The normal mean relative humidity of the air under the hen on the nest is about 60. More moisture than this is not needed, and good hatches may be had with less. Hot air evaporates moisture and enlarges the air cells of the eggs. When the air cells are smaller than normal, they may be enlarged by more ventilation and less moisture. If moisture is lacking inside the egg chamber, it must be supplied in some way or the success of the hatch may be impaired.

Ventilation in Incubators.—Proper ventilation is of vital importance, because the moisture content of the eggs is largely controlled by ventilation, and it must be rigidly maintained. Moisture and ventilation are not controlled in the same way in all incubators. The directions for operating each kind of incubator are explicit with reference to these two matters, and it is usually a safe, correct practice to follow these directions closely.

Faults in Operation of Incubators.—Bad odors and smoking lamps are often due to poor oil; unless this fault is remedied the hatch will be spoiled. Imperfect lamps, short wicks, or wicks that are filled up in the web are also serious obstacles to success in artificial incubation. The best obtainable lamps and wicks are often faulty. If they are defective in any respect they render the keeping of an even temperature difficult or impossible. An even heat current cannot be maintained unless the incubator is absolutely level on top. Flues that are clogged with soot fail in heating; oil-covered lamps soil the hands and when they become heated pass the odor of oil through the heater into the egg chamber.

The handling or turning of eggs with hands that are soiled with oil destroys the embryo in the shell. Too much haste in warming overheats the eggs and kills the germs; a sudden jar of the incubator separates the yolk in the egg and the chick promptly dies. If the eggs are left out to cool until they are chilled, they will not hatch. Lamps irregularly filled, carelessly trimmed, and allowed to burn too high or too low assure failure, as will also neglect in turning and airing the eggs. If the operator neglects the eggs in the incubator, failure is as certain as it is when the hen neglects her nest.

Not all incubators are constructed alike, and the best results are secured by following the special directions for operation that are usually furnished with the machine.

FACTORS THAT INFLUENCE SUCCESS IN INCUBATION

The factor of prime importance in incubation is the vitality of the eggs, and this depends on the vitality of the fowls that produce them.

Eggs for hatching should all be of one kind, size, and color.

Only smooth and well-formed eggs should be used for hatching. Eggs of bad form or with rough shells should be discarded.

The best eggs for hatching are those that are placed in an incubator on the day they are laid; eggs are in good condition for hatching up to 10 da. after they are laid; after they are 2 wk. old they are unreliable.

Clean eggs are the best, but eggs should not be washed. Washed eggs do not hatch well.

The incubator must be set up perfectly level and kept so for best results.

The directions given by the manufacturers for the operations of their machines must be closely followed.

The thermometers recommended by the manufacturers of the incubators should be used, and they should be placed in the machine exactly where directed.

Incubator eggs should not be handled with hands soiled by dirt or oil. Oil will kill the germ within the egg.

Avoid jars to the incubator while hatching. This ruptures the egg and destroys the embryo.

The incubator room should be kept free of drafts and bad odors of all kinds.

Keep the flues of the incubator clean and free from soot. This prevents the proper amount of heat from reaching the egg chamber.

Keep the lamps clean and free from oil. Oil odors affect the eggs, and may even destroy the embryos.

When the eggs are first placed in the incubator, they should be warmed gradually. If they are heated too fast the germs will be destroyed.

Do not neglect to turn and air the eggs in an incubator.

When the eggs are taken out of an incubator to air, the door should be closed so that the egg chamber will not cool off. The eggs should not be kept out of the chamber until they become chilled. This kills the embryos.

Be sure to have the brooders prepared for the accommodation of the chicks when they are ready to be taken from the incubator.

When the incubator is not in use, keep it in a place where it will not become infested with vermin. When it is again put in use, it should be examined, thoroughly cleaned, and run for several days before the eggs are placed in it.

TESTING FERTILITY OF EGGS

After hen's eggs have been incubated for some time, it is usually desirable that they be examined for fertility. This examination should be made during the



FIG. 3

seventh day of incubation, and while the work of testing the egg can be done in daylight, it is usually well to do the work after dark. The egg may be tested without the aid of any appliance except a lamp. As shown in Fig. 3, the hand of the tester shades the lamplight so that the light transmitted through the egg may be apparent to

the tester, or the light may be shaded by means of a cardboard in which an egg-shaped hole has been cut, as shown in Fig. 4. No matter what

method is used, the eggs that are infertile and in which the germs are dead may be quickly separated from the fertile ones, as the developing embryo appears as a



FIG. 4

dark spot in the otherwise clear white of the egg. The clear eggs should be removed, as further incubation

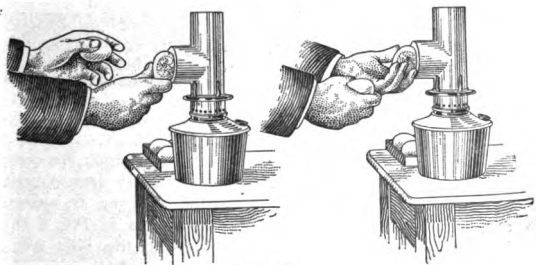

FIG. 5

of them is useless. It is generally advisable to combine the fertile eggs of three or four hens, placing them

under two hens and supplying those hens from which the eggs have been removed with other eggs. Vigorous hens can endure the strain of the second hatching.

The use of bull's-eye lamps, or lanterns, as shown in Fig. 5 makes the work more efficient by magnifying the germ, thus emphasizing the difference between the living and the dead germs. When the egg is laid against the opening with the large end up, the air cell is seen at the top and the fertility or non-fertility of the egg is readily perceived. The egg must fit close against the rubber front so as to cut off the side light.

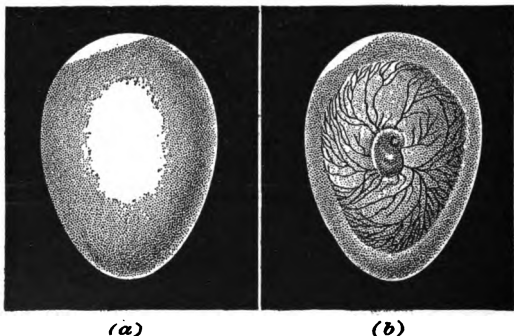

FIG. 6

When held against the opening through which the light comes, the clear, or infertile, egg is nearly transparent, as shown in Fig. 6 (a). If fertile, the egg is opaque and the embryo is plainly seen, as shown in Fig. 6 (b). Some eggs show a brown shadow over the side as if a veil were interposed between the shell and the germ. The size of this apparent veil varies. Eggs that have thick, dark shells do not show the veil so plainly as do those that have thin or white shells.

Dead germs, or spoiled eggs, show in several ways: the inactive or dead germ and the separate yolk are not clearly defined; the blood markings do not have venous outlines; irregular lines without connections are seen; and the entire egg structure lacks the definiteness of that of eggs that contain living embryos. With practice, the merest amateur becomes familiar with these distinctive conditions as viewed through the tester in a darkened room.

BROODING

NATURAL BROODING

Brooding is the process of warming and caring for chicks from the time they emerge from the shell until they are old enough to withstand ordinary temperatures and to shift for themselves. When the chicks are kept warm and are cared for by a hen the process is called natural brooding. When the warmth and protection is supplied by some mechanical device, or brooder, and the chicks are otherwise cared for by an attendant, the process is called artificial brooding.

Brood Coops.—In natural brooding suitable brood coops are essential; such coops should be free from dampness, well ventilated, comfortably warm but not too hot, and large enough that the chicks will not be cramped for space. Where cats, rats, and other predatory animals are a menace, coops with covered runways are indispensable.

A large brood coop that will house three or four hens and their broods is shown in Fig. 1. This is a strongly built coop 6 ft. long, 3 ft. deep, and 3 ft. high in front. The upper part of the front is enclosed with wire netting, the lower part with strips of wood. The board doors close over the slats, which may be removed when the chicks are large enough to run

about with the hen. A coop of this size will accommodate from 50 to 60 chicks; six of these coops will accommodate 300 chicks after they are weaned. The board floors are covered with earth or sand, which may be cleaned away quickly when necessary. Such coops are warm enough for cool weather and may be opened for ventilation when the weather is warm; if roost poles are set in place, the chicks can continue to occupy the coops until winter.

During the summer months, coops of this kind partly hidden by bushes and weeds serve in the daytime as a place in which the hen and chicks may find shelter from the heat and rain and protection from birds of prey. The lower doors should be closed at night to protect the inmates from nocturnal prowlers.

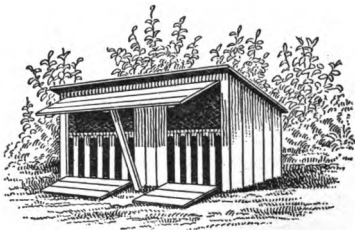

FIG. 1

The small brood coop shown in Fig. 2 is suitable for one hen and a brood of chicks, and will afford good protection from all small animals likely to prey on them. These coops are 2 ft. square and 2 ft. high in front. The glass window in the lower part of the front is made to slide so that the hen and chicks may be let out when desired. The coop is ventilated by means of the netting under the hood that shelters the front of the coop from sun and rain. These coops have board floors and shingle roofs, and they are made of

1-in. lumber dressed on both sides. Coops of this kind may be located in lots that are enclosed with wire fence.

To keep them sanitary and free from insect vermin brood coops are sprayed inside and outside with crude petroleum or creosote or kerosene or some other liquid insecticide; and the paint should be applied at least a week before the coop is occupied. Of the three insecticides named, creosote, which may be obtained in paint stores, is best. Brood coops should be sprayed inside and outside every 2 wk. with an insecticide of some kind, the work being done in the morning when the hen and chicks are ranging, in order to avoid injury to the chicks by the fumes of the liquid used. The floor of the brood coop must be cleaned frequently to avoid the accumulation of droppings and other filth, because odors that are injurious to both hen and chicks arise from such accumulations.



FIG. 2

Weaning Age.—When she is permitted to do so, the mother hen weans the chicks when they are from 6 to 8 wk. of age, although some hens are ready to leave the chicks when they are 4 to 5 wk. old, and a few other hens will continue to mother their chicks until they are 12 wk. old. If she is confined to the brood coop and not permitted to wander, the hen may be kept with the chicks until their covering of feathers is complete. The chicks should not be weaned until they are sufficiently grown to care for themselves and to be warm at night. Up to the first of June they do well if they are kept with the hen until they are 10 or 12 wk. old; from June to Oct. they are usually fit to wean at the age of 8 wk.; and if they are unusually

well grown, they can care for themselves at a younger age. Regardless of age, the chicks should remain with the hen until they are fit to care for themselves, this fitness depending on size and a sufficiency of feathers to keep the chicks warm at night.

ARTIFICIAL BROODING

Brooders.—A mechanical device for aiding in raising chicks without the care of hens is called a *brooder*. The essential parts of a brooder are the *hover* and the *nursery*. The hover supplies the heat necessary to keep the chicks warm; the nursery is the exercising room for

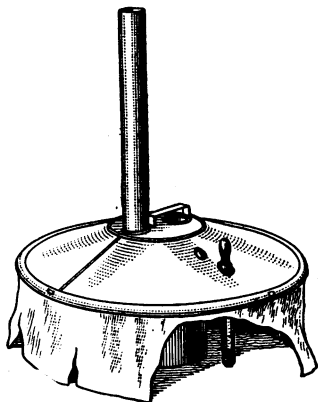

FIG. 3

the chicks. A brooder should be so arranged that the chicks will have plenty of room, sunshine, warmth, and fresh air; a brooder that supplies all these necessities forms a comfortable home for the chicks. If any of the foregoing requisites are lacking, the strain of artificial brooding will be most trying on the vitality of the chicks and injurious to their health. The best brooders are those that have all the requirements necessary

for growing the chicks to a healthy maturity.

Hovers are heated in several ways, but those that are heated with lamps have the advantage of uniform heat and good ventilation. Lamps give the most satisfactory heat for small brooders, and they are

also used for heating brooders that have a capacity for more than a hundred chicks. All of the several systems used in brooding have lamps as the source of heat for small brooders.

A successful type of hover is shown in Fig. 3. This is circular, allowing no corners for chicks to crowd in, and because of the way in which the heat from the lamp is deflected, the space immediately behind the curtain is warmer than the space next to the lamp, thus removing any inclination on the part of the chicks

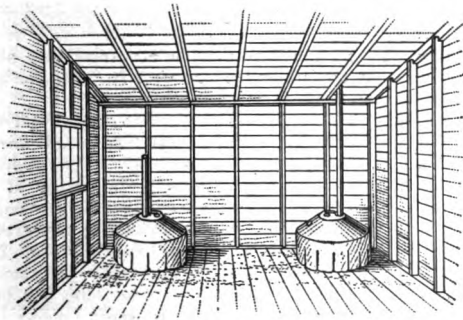

FIG. 4

to huddle together. These hovers may be used in a brood coop, the unoccupied space in the coop being used for the nursery, or they may be placed in a house with a small wire-netting fence about each to prevent the chicks from wandering away from the hover. Two of these hovers arranged in this way are shown in Fig. 4.

In Fig. 5 is shown another type of hover in a two-apartment colony brooder coop. The hover is shown in the left-hand section of the brood coop. The right-hand section may also hold a hover if desired. After

the chicks have grown to sufficient size the hover may be removed and coop used as a colony coop for the

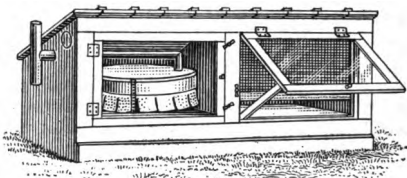

FIG. 5

growing chicks. When this is done a roost pole about 3 in. wide on top and placed about 1 ft. from the back and 8 in. above the floor is put in the coop.

Brooding boxes of the type shown in Fig. 6 and that can be used without artificial heat are called fireless brooders. Chicks in brooders of this kind are warmed by the heat from their own bodies; the linings of the box hold the heat about the chicks, thereby preventing them from suffering from the cold unless the temperature

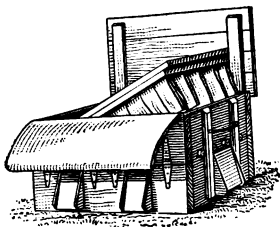

FIG. 6

is extremely low. During cold or stormy weather, the box must be kept indoors. A box that is 24 in. square and 12 in. high can be made as shown in Fig. 7. The inside of the box must be lined with woolen cloth and woolen cloth must hang from the lids, as shown in the two illustrations. There

must be small round holes *a* through both sides of the box for ventilation. The floor of the box must be covered 2 or 3 in. deep with fine-cut clover hay or chaff.

It is quite difficult to have both heat and ventilation if 25 or 30 chicks are shut up in a box of this kind. They will keep warm enough to live, but without ventilation they will die.

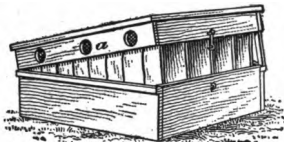

FIG. 7

Temperature for Brooders. — Proper warmth is of prime importance in artificial brooding. If the chicks are chilled, they are of little value thereafter; if overheated, they lose vitality. The frequent occurrence of either chilling or overheating or both will destroy an entire lot of chicks. A temperature of about 105° F. does not injure the young chicks half as much as a temperature of 60° F. A chill causes indigestion, loss of appetite, and bowel trouble, from which the chick seldom or never recovers. The proper degree of heat should be maintained with absolute regularity, and there should be none but the slightest change of temperature inside the brooder.

The temperature inside the brooder beneath the hover where the chicks go to keep warm should be 90° F., during the first 7 da. This temperature should be reduced a little each day thereafter until the temperature is 80° F. beneath the hover. This is the correct temperature for the young chicks; if the chicks are warmer than this they suffer from the heat; if the temperature is less, the chicks are chilled and ailments result. With this temperature beneath the hover, the nursery should be about 70° F. The chicks come from the nursery of the incubator where the heat is about 95° F. and at first they should have the same degree of heat in the hover.

Securing of Proper Temperature.—The lamp for the brooder should be large enough to hold sufficient oil for 1 day's burning. It must be strongly made of heavy metal, so that it will stand rough usage. The wick in the lamp must be long, and both the wick and the

lamp must be kept perfectly clean. The charred or burnt part should be removed daily from the wick. In order to regulate the heat and thoroughly dry out the inside of the brooder, the lamp must be lighted a day in advance of the coming of the chicks.

The directions for operating brooders recommend temperatures that range from 85° F. to 110° F. during the first 2 wk. Although these records differ 25° F., the temperature beneath the hover should be alike in all. Brooders of different construction show different readings of temperature, because the thermometer used was placed near the heat supply or far from it, in accordance with the different methods of heating. From this it will be understood that each brooder must have a thermometer suited to its heating equipment and that no other kind will accurately register the degree of heat that is required for the brooder in use.

Not all brooder thermometers are alike nor are they placed in the same positions in the brooder. If a short thermometer should be used where a long one is required, the temperature would be taken above the proper line. Because of this fact an incorrect idea would be obtained of the heat conditions within the brooder, which would probably be kept too cold, thus causing the chicks to crowd together to keep warm. Long thermometers, as shown in Fig. 8 (a), are suited to some brooders, and short thermometers as shown in (b) are suited to others. If one thermometer is used where the other should be used, the temperature inside of the hover will not be correctly taken. Each kind of a brooder must have a thermometer that takes the temperature from a given line beneath the hover; the position of this line is given in the manufacturer's directions for operating the brooder. No rule other than the one given in those directions is safe to follow, and the thermometer to be used must be adapted to the brooder in which it is placed.

The temperature within the hover is regulated by the size of the flame of the lamp. The flame should be

shaped like that of the most perfectly trimmed house lamp; that is, it should conform to the shape of the burner top—slightly higher at the center and of crescent shape. A pointed or irregular flame is liable to cause trouble. The flame of the lamp should be increased if more heat is needed and should be lowered to lessen the heat. In some brooders, automatic regulators assist in keeping an even temperature beneath the hover, but they are not absolutely to be relied on. The heat in the brooder should be regulated to conform to weather conditions. When it is cold or damp outside, more heat is needed under the hover and in the nursery than is needed when a higher temperature is at hand.

Troubles of Chicks Due to Lack of Care in Brooding. Brooder chicks are more subject to certain troubles than those brooded naturally, due to the failure to provide the right conditions and a lack of care in brooding. Weakness of the legs, contraction of the muscles, crooked toes, and vertigo are among the ailments most prevalent among brooder chicks.

They result from overheating, from chilling, or from eating unwholesome food. Slipping on smooth places may bend the legs of young chicks. Overheating will cause them to suffer, and too much heat under the floor will shrivel the flesh on their shanks and feet. None of these troubles will occur in broods of chicks that are raised in a brooder environment that is reasonably good.

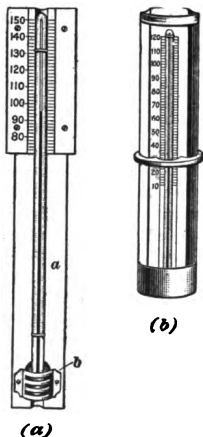

FIG. 8

POINTS IN SUCCESSFUL BROODING

Brood coops should be perfectly sanitary and free from vermin, and should be painted with liquid insecticide at least a week before they are occupied. They should also be sprayed with insecticide every 2 wk. while in use, and the floors must be cleaned frequently.

Brood coops should be ready a day in advance of the time when the chicks are to be placed in them, and the temperature should be about 90°. This temperature should be maintained for 7 da., after which it should be gradually reduced to 80°.

If newly-hatched chicks become chilled they will be seriously injured, and if they are overheated they will lose vitality. The proper heat must be maintained with regularity.

The directions given by the manufacturers for the operation of brooders should be strictly followed, and the particular kind of thermometer recommended should be used. Temperature readings are taken at different heights, according to the construction of the brooder, and if the thermometers used are too long or too short the temperature readings will be misleading.

Overcrowding in brooders should be avoided. When a brooder is overcrowded the air becomes impure, and this will result in a loss of vitality.

As soon as chicks are able they should be allowed to run in the open, but they should be protected from predatory animals by covered runways.

During inclement weather chicks should be induced to take exercise by scattering small grains in the litter.

After each meal, unconsumed food should be removed from the floor of the brooder. If it is left to be trampled over and becomes sour, it will cause bowel troubles.

Chicks that contract ailments of any kind should be isolated immediately.

A critical stage in the life of chicks is when they are feathering, and at this time they should be supplied with an abundance of nitrogenous foods.

EGGS

Food Value of Eggs.—Eggs are a cheap food. At 25c. a dozen they are less costly than most meats. One dozen eggs will better serve a family of six than $1\frac{1}{2}$ lb. of meat, a fair valuation of which is about 30c.

A comparison of the relative food value of eggs, meat, and bread is favorable to bread, yet bread does not fully supply the needs of the body. If 10c. were spent for five eggs that contain about .6 lb. of total food, it would provide .08 lb. of protein and .05 lb. of fat having a fuel value of 425 calories. The same amount expended for lean meat at 20c. per pound would buy .5 lb. of food material that contains about .08 lb. of protein and .09 lb. of fat having a fuel value of 643 calories. The same sum spent for bread would buy a 2-lb. loaf, which would contain about .18 lb. of protein, .03 lb. of fat, and 1.06 lb. of carbohydrates having a fuel value of 2,532 calories. From the foregoing it will be seen that eggs do not furnish the heat-producing materials in such large quantities as do meat and bread.

Composition of Eggs.—About 11% of hens' eggs consist of shell, 32% of yolk, and 57% of white. The white and yolk are made up of 72% of water. The accompanying table, adapted from a bulletin of the United States Department of Agriculture, gives the composition and fuel value of the eggs of the common domestic poultry, and, for purpose of comparison, the composition and fuel value of some of the more common foods other than these.

Uses of Eggs.—In addition to their use as food, eggs are used to a limited extent for other purposes. The white of an egg is a remedy for burns, and if taken in time it is an effective antidote for poisoning by corrosive sublimate. Food or bones lodged in the throat can sometimes be dislodged by swallowing a raw egg. The oil extracted from the yolk has healing properties,

COMPOSITION OF EGGS AND CERTAIN OTHER FOODS

Food	Refuse Per Cent.	Water Per Cent.	Protein Per Cent.	Fat Per Cent.	Carbo- hy- drates Per Cent.	Ash Per Cent.	Fuel Value Per Pound Calories
<i>Hen egg:</i>							
Whole egg as purchased.....	11.2	65.5	11.9	9.30		.9	711
Whole egg, edible portion.....		73.7	13.4	10.50		1.0	802
White.....		86.2	12.3	.20		.6	338
Yolk.....		49.5	15.7	33.30		1.1	1,825
Whole egg boiled, edible portion.....		73.3	13.2	12.00		.8	860
White-shelled eggs as purchased.....	10.7	65.6	11.8	10.80		.6	771
Brown-shelled eggs as purchased.....	10.9	64.8	11.9	11.20		.7	791
<i>Duck egg:</i>							
Whole egg as purchased.....	13.7	60.8	12.1	12.50		.8	851
Whole egg, edible portion.....		70.5	13.3	14.50		1.0	968
White.....		87.0	11.1	.03		.8	298
Yolk.....		45.8	16.8	36.20		1.2	1,977
<i>Goose egg:</i>							
Whole egg as purchased.....	14.2	59.7	12.9	12.30		.9	864
Whole egg, edible portion.....		69.5	13.8	14.40		1.0	977

EGGS

White.....	86.3	11.6	.02		.8	311
Yolk.....	44.1	17.3	36.20		1.3	1,990
Turkey eggs:						
Whole egg as purchased.....	13.8	12.2	9.70		.8	736
Whole egg, edible portion.....	63.5	13.4	11.20		.9	831
White.....	86.7	11.5	.03		.8	309
Yolk.....	48.3	17.4	32.90		1.2	1,854
Guinea fowl:						
Whole egg as purchased.....	16.9	11.9	9.90		.8	736
Whole egg, edible portion.....	72.8	13.5	12.00		.9	868
White.....	86.6	11.6	.03		.8	312
Yolk.....	49.7	16.7	31.80		1.2	1,788
Miscellaneous foods:						
Cheese as purchased.....	34.2	25.9	33.70	2.4	3.8	2,158
Sirloin steak as purchased.....	54.0	16.5	16.10		.9	1,121
Sirloin steak, edible portion.....	61.9	18.9	18.50		1.0	1,286
Milk.....	87.0	3.3	4.00	5.0	.7	348
Oysters in shell as purchased.....	16.1	1.2	.20	.7	.4	53
Oysters, edible portion.....	86.9	6.2	1.20	3.7	2.0	284
Wheat flour.....	12.0	11.4	1.00	75.1	.5	1,710
Potatoes as purchased.....	62.6	1.8	.10	14.7	.8	319
Potatoes, edible portion.....	78.3	2.2	.10	18.4	1.0	397

and the inner lining or membrane of the shell can be used as an adhesive plaster. Eggshells, on account of the purity of the carbonate of lime of which they are largely composed, are used in compounding medicine and for several other purposes.

There is a limited demand for rotten eggs for the finishing of some kinds of leather. They may be used as fertilizer, and in many instances they are used in the manufacture of calico. The supply, however, is much greater than the demand, and such eggs bring but a few cents a dozen. Often the price paid for them is not sufficient to cover the cost of transportation, which in most cases is paid by the shipper.

Color of Eggshells.—Fowls of European origin lay white-shelled eggs; those of Asiatic origin lay dark-shelled eggs, as a rule. The eggs of different varieties of the same breed may differ slightly in color. For example, the eggs of dark-plumaged fowls have darker-colored shells than those of the lighter-plumaged fowls.

A cross between two breeds, one of which lays brown-shelled eggs and the other white-shelled eggs, results in fowls that lay eggs of a color intermediate between the brown and the white. There is also considerable variation in the color of eggs from different hens of the same variety. The color of the shell is more pronounced in the eggs first laid than in those laid later in the season. All fowls having the least amount of Asiatic blood show this influence in the tinted shells. The more of Asiatic blood a fowl has in its veins the darker will be the color of the eggshell. The eggs with the darkest color of shell are laid by the Langshans.

The New York market pays the highest prices for white-shelled eggs, and the Boston market pays the highest prices for brown-shelled eggs. In other markets the matter of color of shell is one of small importance.

The color of shell produced by the most popular egg-producing breeds is given in the following list.

Brown Shells

Brahmas
 Cochins
 Dorkings
 Dominiques
 Faverolles
 Indian Games
 Javas
 Langshans
 Orpingtons
 Plymouth Rocks
 Rhode Island Reds
 Wyandottes

White Shells

Anconas
 Andalusians
 Crèveçœurs
 Campines
 Games (some have a tint)
 Hamburgs
 Houdans
 Leghorns
 La Flèche
 Minorcas
 Polish
 Redcaps
 Spanish

Weight of Eggs.—Marketable eggs should weigh not less than 2 oz. each. At this weight, a crate of 30 doz. eggs will weigh 45 lb., exclusive of the crate, and such eggs will bring much better prices in the market than eggs of smaller size. Eggs much larger than 2 oz. are not profitable to sell, because they bring very little, if any, higher price in the general market, and hens do not lay as many. For a special market, however, it is sometimes possible to get a premium on eggs that average about $2\frac{1}{2}$ oz.

The weight of eggs depends to a large extent on the breed of fowls that lay them and also on the peculiarities of individual fowls. The following, however, gives the average weight of various eggs:

<i>Eggs</i>	<i>Ounces</i>
8 hens' eggs, average	16
11 guinea eggs	16
1 duck egg	3
1 turkey egg	4
1 goose egg	6 to 7

Washing of Eggs.—Eggs that are so badly soiled as to need washing to fit them for market may be cleaned with a solution made up of 1 oz. of ammonia to 2 qt. of water. Soiled eggs may also be washed in warm water and rubbed dry with a piece of cotton cloth or flannel. Deep stains may be removed by rubbing with dry, coarse salt. When cleaned in this way they should be

rinsed in lukewarm water. Stained eggs are sometimes cleaned in lukewarm water that contains a small quantity of soap.

After soiled eggs have been cleaned their appearance is improved by rubbing them with a cloth that has been moistened with a solution made up of 4 oz. of salt to 1 pt. of vinegar; this treatment, however, is not necessary for eggs that have been washed in a solution containing ammonia.

Fluctuation of the Egg Yield.—The yield of eggs begins to decline in the warm months, just before the molt begins—in the northern hemisphere, in July and Aug. In that hemisphere the yield steadily declines until Nov. or Dec., when the minimum number of eggs

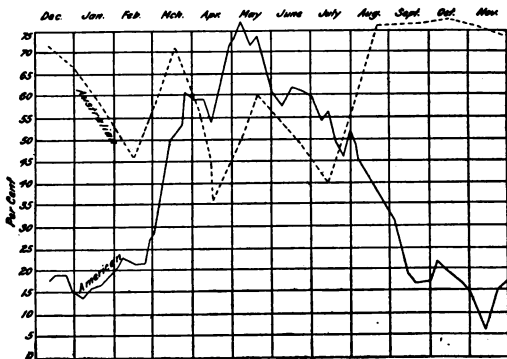

is produced. In Jan. the yield begins to grow larger and increases steadily until the growing season, the maximum usually coming in April or May. The rise and decline of the egg yield are, of course, reversed in the southern hemisphere. The accompanying illustration shows the percentage yield of eggs by months in the

United States as compared with Australia. As shown by this figure a daily egg yield of 73% during Dec. may be obtained from a flock of good hens in Australia, and in that month in the United States similar hens may give but an 18% yield.

In all localities the fewest eggs are produced during the season of molt and the period immediately following that season. In the United States, the molt occurs during the months that intervene between July and Jan. Naturally, eggs will sell for the highest prices at this time. Hens should be encouraged to lay during these months. To accomplish this, pullets must be hatched in March or earlier, and hens should molt during Aug. There is more heat and less cold in Australia than in the United States, but the greater profit will be made when a prolific yield of eggs during the winter months has been secured.

Percentage of Loss of Total Egg Crop.—According to the United States Department of Agriculture, about 17% of the total egg crop of the country is lost, because of improper handling, or because of unsanitary conditions where the eggs are laid. The accompanying table shows the percentage of loss of the total egg crop due to various causes.

PERCENTAGE LOSS OF TOTAL EGG CROP

Class	Per Cent.
Dirty eggs.....	2
Broken eggs.....	2
Chick development.....	5
Shrunken or held eggs.....	5
Rotten eggs.....	2½
Moldy and bad-flavored eggs	½
Total.....	17

EGG PRODUCTION RECORDS

Variations in Egg Production.—The egg records given in the accompanying table show the actual performance of four hens from the same flock and illustrate the importance of selecting for breeding purposes hens with an established record.

3-YR. EGG RECORD

Year	Number of Eggs Laid			
	Hen A	Hen B	Hen C	Hen D
First.....	207	186	202	170
Second.....	185	197	129	30
Third.....	136	117	96	0
Total eggs laid in 3 yr....	528	500	427	200

A was the strongest and most persistent layer; in her third year she laid more than most hens do in their first year. B and C were also good layers. Although D was a good layer in her first year, she was unable to continue laying the second year. Hens with a record like hers must not be selected to keep up a flock. Her small ability would not have been discovered had she not been retained and a careful record of her performance kept. It is only by keeping such records that the poor layers can be discovered and eliminated, and a desirable strain established. Little is known of the largest possible egg yields, but it is certain that there are hens that are capable of producing more than 500 eggs in 3 yr. With a flock of such hens as an ultimate goal, satisfactory results are bound to be achieved, provided the right individuals are selected to maintain the flock. Pullets that are hatched in the

early spring lay at an earlier age than do late-hatched pullets. March-hatched pullets frequently lay in July, while those hatched in July seldom lay before the following March.

Relation of Weight of Eggs to Egg Production.—As a general rule, the larger the number of eggs laid by a fowl, the lighter in weight the eggs will average. This is shown in the accompanying table, which is a summary of the egg record of 4,362 hens of fifteen different varieties that laid a total of 732,082 eggs, the records of the different lots of fowls being taken over a period of 5 yr. In the table, the fowls are arranged with those laying the heaviest eggs per doz. at the top and those laying the lighter eggs coming in their proper

RELATION OF WEIGHT OF EGGS TO EGG PRODUCTION

Variety	Number of Hens	Number of Eggs Laid	Weight per Dozen Ounces	Average Number of Eggs
Andalusian	72	11,883	26.85	162.26
Single-Comb Black Minorca	156	23,910	26.72	146.85
Langshan	108	17,766	26.03	164.50
White Leghorn	984	173,939	26.00	176.75
Ancona	42	5,883	25.94	140.00
Black Orpington	954	162,623	25.61	170.45
Buff Orpington	234	35,199	25.25	150.42
Buff Wyandotte	66	10,479	24.71	157.85
Silver Wyandotte	834	139,694	24.50	167.49
Brown Leghorn	180	32,593	24.47	181.08
White Wyandotte	90	14,066	24.45	156.25
Golden Wyandotte	108	16,902	24.38	156.50
Rose-Comb White Leghorn	66	11,578	24.31	173.90
Black Hamburg	30	5,554	24.19	185.00
Rose-Comb Brown Leghorn	72	13,155	22.74	182.70
Total, all varieties...	4,362	732,082	25.28	167.50

order. The Black Hamburgs and the Rose-Comb Brown Leghorns that produced the two highest average egg records produced the lightest-weight eggs, and though the results obtained are not all exactly in accordance with this statement, a careful inspection of the table will show that on an average hens with high egg records produced light-weight eggs, and that the hens with the lowest egg records produced somewhat heavier eggs. Since little attention is paid in the market to the weight of eggs, it is obvious that the best egg producers are the most profitable.

Relation of Egg Production to Season.—In spite of the many assertions that hens lay more prolifically at one time of the year than at another, an inspection of the egg records of a large number of fowls fails to show any uniformity in regard to this point, but rather tends to indicate that egg production is more a matter of individuality than of season. The egg records given in the accompanying table have been taken from laying hens in America, England, and Australia. The records of some exceptionally high egg producers have been selected and also the average production of a large number of fowls where it was possible to obtain authentic records of this character. It will be noted that the individual fowls that make high egg records lay consistently throughout almost every month in the year, and that the only time when they fall off in egg production is during the molting period or when they are broody.

The single hens that do not make such high egg records usually lay very well for certain months in the year, but are unable to stand the strain of heavy egg laying and fail, sometimes almost completely, in other months.

When the average egg production of a large number of fowls is taken, it will be seen that there is a certain similarity between their rates of monthly production, but if the record of the 80 White Leghorn hens in America is compared with that of the 28

MONTHLY EGG RECORDS SHOWING ABSENCE OF UNIFORM PRODUCTION

Laying Hens	Jan.	Feb.	Mr. Apr.	May	June	July	Aug.	Sep.	Oct.	No. Dec.	Total	
<i>American records:</i>												
White Leghorn, single hen	20	19	25	23	23	25	26	23	19	12	17	257
First year of laying.....	0	10	17	19	24	25	27	23	21	0	0	189
Second year of laying.....	15	19	21	17	16	11	4	3	3	5	11	146
White Leghorn, av. of 80 hens.												
Rose-Comb Rhode Island Red, single hen	30	27	23	19	25	18	13	15	1	15	28	241
First year of laying.....	16	24	17	14	13	14	13	7	2	10	29	173
Second year of laying.....												
White Wyandotte, average of 28 pullets.....	15	17	22	20	17	15	13	14	9	10	12	183
Assorted varieties, average of 6,771 hens and pullets....	8	11	16	16	14	13	10	6	4	4	7	127
<i>English records:</i>												
Single hen												
First year of laying.....	24	23	29	0	22	24	22	18	15	24	18	229
Second year of laying.....	21	21	23	0	23	19	26	24	12	0	10	191
<i>Australian records:</i>												
White Leghorn, single hen	19	15	22	19	17	14	26	26	27	24	22	243
First year of laying.....	18	14	15	3	0	18	21	23	20	24	21	192
Second year of laying.....												
White Leghorn, single hen	13	2	7	7	4	13	22	21	19	19	19	151
First year of laying.....	8	1	0	0	0	0	13	22	23	22	22	113
Second year of laying.....												
Silver Wyandotte, single hen	16	16	17	13	13	20	24	21	21	21	23	217
First year of laying.....	10	7	12	6	8	13	14	15	6	8	9	111
Second year of laying.....												
Assorted varieties, average of 534 pullets.....	16	13	10	11	12	14	20	22	22	20	19	192

American Wyandottes and the 6,771 hens of assorted varieties in America, it will be seen that the egg production in the cold months was fully as large as in the spring months, and that the production declined only in the fall when the fowls were molting. Some hens that are prolific egg producers in their first year prove very unsatisfactory in their subsequent years, as for instance, the Australian Silver Wyandotte noted in the table. To be sure that no such hens are selected for breeders, it is necessary that careful egg records be kept.

PRESERVATION OF EGGS

COLD STORAGE OF EGGS

Eggs intended for storage must be selected with care and must be packed in clean cases. When so selected and packed and kept at temperatures that range from 29° F. to 34° F., very little, if any, change takes place in the quality of the eggs. While in storage, they should be protected as far as possible from air circulation, as this increases evaporation and causes the eggs to shrink. On removing the eggs from storage, they should be kept at a temperature not warmer than 42° F. until exposed for sale. When it becomes necessary to expose the eggs, it should be done gradually in order to avoid sweating.

The air in cold-storage houses should be free from moisture and bad odors of every kind. The yolks of eggs kept long in storage at a temperature of 32° F. settle to one side, unless the eggs are occasionally moved about. At temperatures lower than 32° F., the eggs become more or less solid and do not require turning.

PICKLING OF EGGS

The success obtained from preserving eggs depends largely on the care given to the selecting of the eggs, the preparation of the preserving liquid, and the placing

of the eggs where the temperature will be even and cool. Eggs laid during the month of April are usually the best for storing. Those laid in May or June are next best. Eggs laid in April are usually very choice, because at this time the fowls have a plentiful supply of fresh green food. Eggs to be stored should be clean and fresh. It is impossible to secure good results in storage from eggs of poor quality.

Eggs may be preserved in *lime water*, provided they are kept in tall vessels; either stone crocks or butter tubs can be used. The liquid for covering the eggs is made in the proportion of 3 gal. of water to 1 lb. of salt and 1 qt. of finely slaked lime, the lime and salt to be mixed in the water. This is to be stirred frequently for a period of 1 to 2 da. Following this, the liquid should be permitted to settle. The crock or tub is then almost filled with eggs, placed, as far as possible, with the small end down. The clear liquid solution of lime and salt is poured over them until the surface of the water is fully an inch above the top of the eggs. The vessel should be kept in an out-of-the-way place, where the temperature will not exceed 50° F. A thin covering of lime will form on the top of the liquid. If undisturbed, this covering will protect the contents from outer influences.

A solution made of 1 gal. silicate of soda, or *water glass*, and 9 gal. water is an efficient preservative for eggs. The water glass is dissolved in warm water and is well stirred until thoroughly mixed with the water. When cool, this solution should be poured over eggs placed in vessels, as described in the foregoing



BLACK ORPINGTON

paragraph. Eggs will keep fairly fresh in this solution for 5 or 6 mo., and they have been kept in edible condition for a year in a solution of this kind. This can be accomplished, however, only when they are kept in cool places and in a temperature that does not exceed 45° F. Experiments have shown that under some conditions a solution of 5% of water glass and 95% of water will answer well for the keeping of eggs; and they will keep fairly well in a 3% solution of the same material. The quality used depends on the strength of the water glass, which is a chemical preparation that may be of several strengths. When the water glass used is of the highest grade, less is required than of the lower grades.

When the eggs are removed from either of these solutions they should be rinsed entirely free from the lime water or the solution of water glass. To do this, the eggs can be placed either in a sieve or colander, and running streams of fresh water permitted to pass through them, or buckets of fresh water may be poured over them. After being thoroughly rinsed, and before they are packed for shipment they should be laid out either on a dry cloth or on boards until they have become thoroughly dry.

STANDARDS FOR EGGS

Eggs are graded in many ways. The number of grades varies in different markets. In general, it may be said that eggs are graded according to their size, shape, color of shell, finish of shell, and general condition.

In England an official standard of points has been adopted for use in grading eggs, but in America there is no official standard that governs the grade of eggs in all markets. The accompanying table gives the American and English standards for eggs; the American scale of points given is of local origin and is intended to be used merely as a suggestion.

STANDARDS FOR EGGS

American Standard		English Standard	
	Points		Points
Shape.....	30	Freshness.....	40
Color and finish.....	40	Size.....	15
Weight.....	15	Texture of shell.....	15
Condition.....	15	Uniformity of size, color, and shape...	15
		Cleanliness and bloom	15
Total	100	Total.....	100

The rules for the classification, grading, and packing of market eggs as adopted by the New York Mercantile Exchange are as follows:

RULE 1.—CLASSIFICATION AND GRADING

1. Eggs shall be classified as "fresh gathered," "held," "refrigerator," and "limed."

2. There shall be grades of "extras," "extra firsts," "firsts," "seconds," "thirds," "No. 1 and 2 dirties," and "checks."

RULE 2

1. All sales of all grades of eggs shall be at mark.

QUALITIES

2. *Fresh gathered extras* shall be free from dirty eggs, of good uniform size, and shall contain reasonably fresh, reasonably full, strong bodied, sweet eggs, at the discretion of the Egg Committee, as follows:

A—90%.

B—80%.

C—65%.

The balance—other than the loss—may be slightly defective in strength or fulness, but must be sweet. The maximum total average loss per case permitted in "extras" shall vary with the requirement of reasonably full, strong bodied eggs as follows:

A—90% full, 1 doz. maximum loss.

B—80% full, 1½ doz. maximum loss.

C—65% full, 2 doz. maximum loss.

When sold, "storage packed" extras must not contain an average of more than 12 cracked or checked eggs per case.

3. *Fresh gathered firsts* (or extra firsts) shall be reasonably clean and of good average size, and shall contain reasonably fresh, reasonably full, strong bodied, sweet eggs, at the discretion of the Egg Committee, as follows:

A—75%.

B—65%.

C—50%.

D—40%.

The balance—other than the loss—may be defective in strength or fulness, but must be sweet. The maximum total average loss per case permitted in "firsts" or "extra firsts" shall vary with the requirement of reasonably full, strong bodied eggs as follows:

A—75% full, 1½ doz. maximum loss.

B—65% full, 2 doz. maximum loss.

C—50% full, 3 doz. maximum loss.

D—40% full, 4 doz. maximum loss.

When sold, "storage packed" fresh gathered firsts (or extra firsts) must not contain an average of more than 18 cracked or checked eggs per case.

4. *Fresh gathered seconds* shall be reasonably clean and of fair average size, and shall contain reasonably fresh, reasonably full eggs, at the discretion of the Egg Committee, as follows:

A—65%.

B—50%.

C—40%.

D—30%.

The balance—other than the loss—may be defective in strength or fulness, but must be merchantable stock. The maximum total average loss per case permitted in

"seconds" shall vary with the proportion of reasonably full eggs required, as follows:

A—65% full, 2 doz. maximum loss.

B—50% full, 3 doz. maximum loss.

C—40% full, 4 doz. maximum loss.

D—30% full, 5 doz. maximum loss.

5. *Fresh gathered thirds* shall be reasonably clean and of fair average size, and shall contain reasonably fresh, reasonably full, sweet eggs, at the discretion of the Egg Committee, as follows:

A—50%.

B—30%.

C—20%.

The balance—other than the loss—may be defective in strength or fulness, but must be merchantable stock. The maximum total average loss per case permitted in "thirds" shall vary with the requirements of reasonably full, sweet eggs, as follows:

A—50% full, 4 doz. maximum loss.

B—30% full, 5 doz. maximum loss.

C—20% full, 6 doz. maximum loss.

6. *Held firsts* shall be reasonably clean, of good average size, and sweet. At least 40% shall be reasonably full and strong. The balance may be defective in strength or fulness, but not badly shrunken, excepting the loss. There may be a total average loss of two doz. per case, but if the loss exceeds that by not more than 50% the eggs shall be a good delivery upon allowance of the excess.

7. *Held seconds* shall be reasonably clean and of fair average size. May be defective in fulness, strength, and flavor, but must be merchantable stock, not musty. There may be a total average loss of 4 doz. per case.

8. *Refrigerator extras* shall be free from dirty or small eggs, reasonably full, strong, sweet, and free from mildew or foreign taste or odor.

The maximum loss shall be, at the discretion of the Egg Committee, as follows:

A—1½ doz.

B—2 doz.

Cases, fillers, and packing shall be as required for "storage packed."

9. *Refrigerator firsts* shall be reasonably clean and of good average size; they must be reasonably full, strong, and sweet, and free from mildew or foreign taste or odor.

The maximum loss shall be, at the discretion of the Egg Committee, as follows:

A—2 doz.

B—3 doz.

Cases, fillers, and packing shall be as required for "storage packed."

10. *Refrigerator seconds* shall be reasonably clean and of fair average size; they must be reasonably full, strong, and sweet, and free from mildew or foreign taste or odor.

The maximum loss shall be, at the discretion of the Egg Committee, as follows:

A—3 doz.

B—4 doz.

Cases shall be substantial, and fillers and packing reasonably sweet.

11. *Refrigerator thirds* shall be of fair appearance and may be off-flavored to some extent.

The maximum loss shall be, at the discretion of the Egg Committee, as follows:

A—5 doz.

B—6 doz.

Cases shall be substantial.

12. *Limed extras* shall be of uniformly good size, well cleaned, strong bodied, and reasonably full and sweet.

The maximum loss shall be, at the discretion of the Egg Committee, as follows:

A—1½ doz.

B—2 doz.

Cases, fillers, and packing shall be as required for "storage packed."

13. *Limed firsts* shall be of good average size, well cleaned, of good strength, reasonably full and sweet.

The maximum loss shall be, at the discretion of the Egg Committee, as follows:

A—2 doz.

B—3 doz.

Cases, fillers, and packing shall be as required for "storage packed."

14. *Limed seconds* shall be of fair average size, well cleaned, of good strength, and reasonably full and sweet.

The maximum loss shall be, at the discretion of the Egg Committee, as follows:

A—3 doz.

B—4 doz.

Cases shall be substantial, and fillers and packing reasonably sweet.

15. *Limed thirds* shall comprise stock which is rusty, weak, or shows hot weather defects, but must contain at least 50% of fairly useful quality.

The maximum loss shall be, at the discretion of the Egg Committee, as follows:

A—5 doz.

B—6 doz.

Cases shall be substantial.

16. *No. 1 dirties* may be offered in the classes of Fresh Gathered, Held, and Refrigerator. They must be of good, useful quality, sweet in flavor.

The maximum loss shall correspond with the requirements for "firsts" in the class, at the time when offered.

When sold "storage packed," No. 1 dirties must not contain more than 18 cracked or checked eggs per case.

17. *No. 2 dirties* may be offered in the classes of Fresh Gathered, Held, and Refrigerator.

The quality, if fresh gathered, shall be the same as specified for No. 1 dirties.

If held, or refrigerator, may be off-flavored, but not musty.

The maximum loss shall correspond with the requirements for "seconds" in the class, and at the time when offered.

Checked eggs may consist of blind checks and cracked eggs (not leaking). They must be sweet in flavor, and the loss must not exceed 3 doz. per case.

18. Loss, as used in these rules, shall comprise all rotten, spotted, broken (leaking), broken-yolked, hatched (blood-veined), and sour eggs. Very small, very dirty, cracked (not leaking), badly heated, badly shrunken, and salt eggs shall be counted as half loss in all grades excepting dirties and checks. * * *

19. At the discretion of the Egg Committee it may put in force two grades of firsts at the same time, one requiring a higher proportion of reasonably full, strong-bodied eggs than the other, and when this is done, the higher of the two grades shall be designated as "extra firsts."

All requirements for grades determined upon by the Egg Committee must be chosen from those specified under Rule 2.

20. The classification provided in this rule shall apply equally to hen eggs, duck and goose eggs, but in the case of duck and goose eggs the maximum loss shall be pro rata with the number of dozens contained in the packages.

RULE 3.—PACKAGES AND PACKING

1. All grades of eggs not storage packed, shall be in new or good second-hand substantial egg cases, of uniform size.

Fillers shall be of substantial quality, sweet and dry, with flats or other suitable substitutes under bottom layers and over tops, and sweet, dry excelsior or other suitable packing under bottom and over tops.

Any grade of eggs not storage packed, which shall inspect in quality according to these rules, but be deficient, not to exceed 10% in flats or other suitable substitutes on tops and bottoms, shall be a good delivery.

2. *Storage packed.* When sold as "storage packed," all grades must be in new 30 doz. cases, well seasoned, smooth, clean, and substantial, fillers dry, sweet,

medium, No. 1, or other good substantial straw board, flats under bottom layers and over tops. The packing shall be dry, sweet excelsior under bottoms and over tops, unless otherwise specified.

3. To be a good delivery, all eggs must be packed in 30 doz. cases except goose eggs, which may be packed in any style of packages containing not less than 10 doz. each, and duck eggs, which may be packed in any style of packages containing not less than 15 doz. each.

EGG PRICES

The average wholesale price of eggs in the New York market is shown in the accompanying table. This table gives a 3-yr. average price paid each week prior to 1909 for near-by fresh eggs.

MARKET PRICE OF EGGS

Month	Per Dozen			
	First Week Cents	Second Week Cents	Third Week Cents	Fourth Week Cents
January.....	32	30	29	30
February.....	29	28	30	23
March.....	23	23	17	17
April.....	18	17	17	18
May.....	18	18	18	18
June.....	18	19	19	19
July.....	19	19	21	21
August.....	21	22	23	23
September.....	24	24	24	24
October.....	25	25	25	26
November.....	29	30	33	33
December.....	32	32	34	33

The great difference in value between the average price of all grades of eggs and fresh eggs is shown in

the accompanying table giving the comparison of monthly average egg prices per dozen for all grades of eggs and for strictly fresh eggs in the New York market prior to 1909.

COMPARISON OF MONTHLY AVERAGE PRICES OF EGGS

Month	Average Price for All Grades Cents	Average Price for Strictly Fresh Eggs Cents
January.....	25.8	42
February.....	24.5	40
March.....	19.3	32
April.....	16.9	30
May.....	16.6	31
June.....	15.5	32
July.....	15.6	35
August.....	17.7	38
September.....	20.7	40
October.....	21.4	42
November.....	26.0	45
December.....	27.7	42

Markets of the World That Govern Egg Quotations. The market quotations for eggs throughout the world are governed largely by the prices paid in the densely populated centers. New York, Boston, and Chicago make the prices for America, and London, Manchester, and Berlin make the prices for Europe. Eggs are quoted by the dozen in America; in London, the quotation is by the long hundred (120). Eggs are designated in the London market according to the locality from which they are sent, and as this is, to a certain extent, an indication of their freshness and quality, it has an influence on the quotations. The highest quotations are for the best English eggs, which are fully equal to fancy hennery eggs in America; and French, Danish, and Italian eggs will grade with near-by eggs and eggs

for storage in America. The best of the eggs that are sent from Ireland to London sell for English eggs, and the rest sell for lower prices. Russian eggs grade about the same as shrunken and ungraded eggs in the New York market.

NEW YORK AND LONDON QUOTATIONS

Kind of Eggs	New York Prices per Dozen Cents	Kind of Eggs	London Prices per 120 Eggs Shillings and Pence
Fancy hennery.....	25	English.....	8/4 to 9/2
Near-by fresh.....	23	Irish.....	7/6 to 7/10
Fit for storage.....	23	French.....	8/3 to 8/9
Brown and mixed.....	22	Danish.....	8/3 to 9/6
Shrunken.....	21	Italian.....	8/0 to 8/6
Ungraded and soiled.	19	Austrian....	7/3 to 8/6
		Russian.....	7/0 to 7/3

A comparison of prices in the New York and London markets is shown in the accompanying table, which gives the quotations in the two markets for the month of May, 1909. As the English shilling is equivalent to 24 $\frac{1}{3}$ cents in American money and an English penny is equivalent to 2 cents, the first London quotation of $\frac{3}{4}$ to $\frac{1}{2}$ for 120 eggs, or 10 doz., is about equal to 20 to 22c. per dozen. The quotations given cannot be accepted as a guide for the selling price of eggs, but they furnish an approximate indication of the relative selling prices in New York and London. It will be noted by comparison that the New York prices are about 10 to 12% higher than the London prices. The fluctuations of prices in both markets at different seasons of the year are about the same.

MARKET POULTRY

Digestibility of Poultry and Other Foods.—In poultry and other meats and fish, about 70% of the protein, 95% of the fat, and 98% of the carbohydrates is digestible. The food principles in vegetable foods are not as fully digestible, for in such foods only about 84% of the protein, 90% of the fat, and 97% of the carbohydrates are digestible.

In the table giving the composition of poultry and certain other foods is shown the composition of some

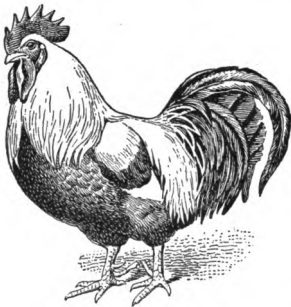

SILVER-GRAY DORKING

foodstuffs, and it will be seen from this that poultry meat compares very favorably in food value with beef, fish, eggs, milk, and potatoes. On an average, the various kinds of poultry furnish not far from 5% more protein and a little more ash than do the other kinds of meat included in the table.

On the other hand, the poultry meats

most used—chicken and fowl—contain relatively little fat and have a relatively small fuel value. Pound for pound, poultry contains a trifle more of the building materials required by the body, but furnishes less of the energy-giving materials than the fat meats. As a general thing, young fowls contain less refuse than older ones, which means that the proportion of total bone weight is smaller; their flesh also contains more water, which indicates that it is not so solid and compact as in older fowls.

COMPARISON OF POULTRY AND CERTAIN OTHER FOODS

Kind of Food	Refuse Per Cent.	Indigestible Nutrients Per Cent.	Water Per Cent.	Protein Per Cent.	Fat Per Cent.	Carbohydrates Per Cent.	Ash Per Cent.	Fuel Value per Pound Calories
<i>Chicken:</i> As purchased...	18.8	.9	55.5	17.3	6.8		.7	749.85
Edible portion.....		1.2	68.4	21.2	8.4		.8	921.71
<i>Fowl:</i> As purchased.....	25.2	1.0	47.3	14.0	12.0		.5	880.89
Edible portion.....		1.7	59.5	19.8	18.2		.8	1,297.66
<i>Turkey:</i> As purchased....	14.3	1.9	49.2	18.4	15.4		.8	1,142.08
Edible portion.....		2.2	57.4	21.5	18.0		.9	1,334.72
<i>Duck:</i> As purchased.....	15.9	1.8	51.4	14.9	15.2		.8	1,039.97
Edible portion.....		2.0	61.1	17.8	18.1		1.0	1,239.91
<i>Goose:</i> As purchased.....	11.1	1.5	48.0	14.4	24.2		.8	1,406.25
Edible portion.....		1.8	54.0	16.1	27.3		.8	1,582.52
<i>Miscellaneous foods:</i> Beef, sirloin steak, as purchased.....	12.8	1.2	54.0	16.0	15.3		.7	1,073.63
Halibut, fresh steaks, as purchased.....	17.7	.7	61.9	14.8	4.2		.7	573.26
Eggs, as purchased.....	11.2	2.3	65.5	11.5	8.8	4.9	.7	679.00
Milk.....		.6	87.0	3.2	3.8		.5	334.85
Wheat bread, white....		3.4	35.6	7.9	1.1	51.1	.9	1,184.98
Potatoes, as purchased.	20.0	.9	62.6	1.5	.1	14.3	.6	303.82

Loss of Weight in Dressing Fowls.—On an average, nearly one-third of the total weight of a fowl is lost in dressing and in preparing it for cooking. In the case of fowls thin in flesh, the loss is much greater than this. The least waste occurs in fowls that have been properly fattened. Excessively fat fowls and also those that are poor in flesh show a large proportion of waste on being dressed.

The table showing the loss in dressing fowls is a summary of an investigation at the Storrs Experiment Station, Connecticut. In this experiment fowls in all conditions—well-fattened, thin, and excessively fat—were used, and their weights at different stages in the process of dressing were noted. Consequently the results given in the table may be considered as applicable to average conditions.

LOSS IN DRESSING FOWLS

Kind of Fowls	Number of Birds	Live Weight Pounds	Weight-Bled and Plucked Pounds	Loss Per Cent.	Weight-Intestines, Head, and Feet Removed Pounds	Loss Per Cent.
Cocks.....	18	127.9	117.9	7.8	97.8	23.5
Cockerels..	278	1,773.0	1,577.5	11.0	1,312.0	26.0
Hens.....	201	1,195.0	1,103.4	7.7	906.3	24.2
Pullets....	47	261.1	240.0	8.1	193.7	25.8
Total...	544	3,357.0	3,038.8	9.5	2,509.8	25.2

The per cent. loss in dressing fowls of different breeds is given in the following table.

Classes of Market Poultry.—There are two general classes of market poultry, the heavy-weight and the medium-weight. The heavy-weight class includes such fowls as the Brahmas, Cochins, Dorkings, and Orpingtons.

LOSS IN DRESSING FOWLS OF DIFFERENT BREEDS

Breed of Fowls	Number of Birds	Live Weight Pounds	Weight—Bled and Plucked Pounds	Loss Per Cent.	Weight—Intestines, Head, and Feet Removed Pounds	Loss Per Cent.
Barred Plymouth Rocks.....	187	1,199.9	1,090.8	9.1	910.4	24.1
White Plymouth Rocks.....	125	859.1	779.4	9.3	644.7	25.0
White Wyandottes.....	103	618.2	558.3	9.7	460.8	25.5
Buff Wyandottes.....	6	39.4	35.2	10.7	28.5	27.7
Rhode Island Reds.....	18	109.7	98.0	10.7	80.2	26.9
Black Langshans.....	32	200.5	182.7	8.9	151.4	24.5
Single-Comb White Leghorns	22	88.3	78.0	11.7	62.1	29.7
Rose-Comb Brown Leghorns.	35	129.6	116.0	10.5	90.4	30.2
White Wyandotte-Light	16	112.3	100.4	10.6	81.3	27.6
Brahma cross.....	544	3,357.0	3,038.8	9.5	2,509.8	25.2
Total.....						

The medium-weight class includes such general-purpose fowls as the Wyandottes and Barred Plymouth Rocks. In addition to these fowls, broilers and other small market fowls are often made from Leghorns and crosses of Leghorns with some of the general-purpose fowls.

Classes of Broilers and Roasters.—Broilers are divided into three classes: squab broilers, spring broilers, and fryers or large broilers or small roasters. *Squab broilers* range in size from $\frac{3}{4}$ to 1 lb. each in weight. They are used by hotels and restaurants during the winter and early spring. *Spring broilers* are used a little later in the season. When plump they range in weight from 1 to $1\frac{1}{2}$ lb. The weight demanded increases as the season advances, until the 2-lb. size is most popular. *Fryers, large broilers, or small roasters* range in weight from 2 to 3 lb. Roasters are generally of two kinds: plump, meaty roasters and soft roasters.

The time required to produce broilers and roasters is shown in the accompanying table. The time required for a chick to grow to marketable size depends largely on the quality of the chick and its breed. Not all breeds mature alike, and the individuals of any one breed will not develop at a uniform rate, but when bred and fed as they ought to be the average is about as indicated in the table.

TIME REQUIRED TO RAISE BROILERS AND ROASTERS

Breeds of Fowls	Growth, in Pounds, in 8 Wk.	Growth, in Pounds, in 10 Wk.	Growth, in Pounds, in 12 Wk.	Growth, in Pounds, in 21 Wk.	Growth, in Pounds, in 26 Wk.	Growth, in Pounds, in 30 Wk.
Leghorns.....	1	1 $\frac{1}{2}$	1 $\frac{1}{4}$	4	6	7
American breeds.....	1	1 $\frac{1}{2}$	2	4	6	7
English and Belgian breeds.....	1	1 $\frac{1}{2}$	2	4	6	7
Brahmas.....	1 $\frac{1}{4}$	2	2 $\frac{1}{4}$	5	7	9

KILLING AND PLUCKING OF POULTRY

Killing.—The most satisfactory methods of killing poultry are by dislocating the neck, and by sticking in the roof of the mouth and piercing the brain with a knife.

In *killing by dislocating the neck*, the fowl is held in front of the operator with the head hanging down; both shanks are firmly grasped with the left hand; the neck of the fowl at the base of the skull is taken between the thumb and forefinger of the right hand, with the back of the hand toward the tail of the fowl and the head held firmly in the palm of the hand; the head is then pulled downwards to extend the neck to its full length; the final step in the operation is taken by pulling with a jerk the already taut neck and at the same time twisting the head upwards. This will dislocate the head from the backbone, paralyzing the fowl, snap the arteries in the neck, and pull the head away from the neck, leaving a cavity in the neck large enough to hold the blood of the fowl. In this operation no blood will escape from the body, and it is preferred by some as the best method of killing fowls intended for immediate sale. When such fowls are prepared for cooking, if the head is severed 1 or 2 in. back of where the blood has settled, all of the blood clot will be removed.

Killing by sticking in the roof of the mouth may be done with a special killing knife or with a common pocket knife that has a sharp point and blade. Both shanks of the fowl are tied with a small piece of rope and the loose end of the rope is tied to some support so that the fowl will hang head downwards and at about the height of the operator's shoulder. The head of the fowl is grasped in the left hand, the mouth pressed open, and the blade of the knife thrust through the roof of the mouth and up into the brain almost in a line with the eye; a cross-cut is made to sever the arteries. This operation paralyzes the fowl instantly, and the cutting

of the arteries allows the fowl to bleed freely from the mouth. To avoid being splashed with blood, the mouth of the fowl should be held away from the operator. This method of killing is commonly practiced in most market poultry establishments.

Plucking.— To make the best appearance when offered for sale in the market, a fowl must be plucked carefully so that the skin will not be torn. An experienced plucker will rub the feathers down the wrong way both on the back and breast, using the flat of his hand to press down and open up the plumage. When the feathers are



HOUDAN

separated in this way they may be quickly plucked from the body by holding the shanks and the tips of the feathers in the hand. The feathers should first be pulled from the back, then from the breast and body, leaving only the long, stiff feathers. These should be plucked and placed by themselves. The best plan is to put the long feathers or those having heavy quills into a box or barrel separate from the smaller or lighter feathers. With some practice

the operator will soon learn to remove all of the feathers quickly from the body of the fowl. The process should begin immediately after the fowl has been killed. By whatever method it is killed, the feathers will come away easier immediately after killing than they will after the body of the fowl has cooled and become set.

The practice of scalding before plucking is generally followed. The chief difficulty in this is that the fowls are dipped into water that is too hot and are frequently kept immersed so long that the skin is scalded and breaks and pulls from the body, leaving an ugly dark

complexion. In scalding the fowls, the water should not be boiling when they are immersed, nor should boiling hot water be poured over them. They should be immersed in water not quite boiling, and as quickly as the feathers are thoroughly soaked they should be plucked gently from the body. Great care should be taken not to tear the flesh or skin.

POULTRY PRICES

A careful inspection of poultry prices over a period of years shows plainly that market poultry of good quality will sell at the highest prices from the middle of Dec. to the end of June. This is due, to a large extent, to the scarcity of farm-grown poultry in the market during these months.

The condition in which poultry is offered for sale has an important influence on the price it will sell for. The relative selling price per pound live weight, plucked weight, and drawn weight of the same fowl is shown in the accompanying table. The plucked weight is the weight of the fowl with the feathers removed but with the head and feet left on. The drawn weight is the weight with the head, feet, and entrails removed and the fowl ready for cooking. It will be seen from this table that the selling price per pound, plucked weight, is about 33 $\frac{1}{8}$ % more than the live weight, and that the price per pound, drawn weight, is about 100% greater

MARKET VALUE OF FOWLS AT DIFFERENT STAGES

Live Weight Cents per Pound	Plucked Weight Cents per Pound	Drawn Weight Cents per Pound
9	12 $\frac{1}{4}$	18 $\frac{1}{4}$
10	13 $\frac{1}{2}$	20
11	14 $\frac{1}{2}$	22
12	16	23 $\frac{1}{2}$

than for the live weight, and about 50% greater than for the plucked weight. This increase in the selling price is due, of course, to the removal of the waste parts and also to the labor entailed. The table furnishes a guide to decide the price to be fixed on the plucked or drawn weight of any grade of poultry.

BREEDING

The most important systems of breeding poultry for exhibition are *line breeding*, *inbreeding*, *strain breeding*, and *cross-breeding*. In any system of breeding, only the best breeding fowls obtainable should ever be used in the breeding pen. All fowls having defects should be promptly discarded, even if this leaves only two or three fowls in the breeding pen. Fully enough poor specimens come from the best matings, and so few good specimens come from matings in which either of the fowls are defective that time and money is wasted in such breeding. Only fowls having the proper size,

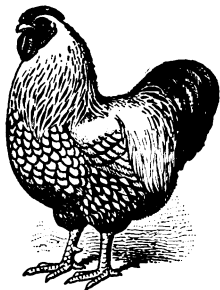

SILVER LACED WYANDOTTE shape, and color required for the variety can produce satisfactory offspring. The plan of mating fowls defective in one section with other fowls having excellent quality in the corresponding section usually results in the production of offspring having not more than medium quality in that section.

Line Breeding.—Line breeding is a system of breeding from a limited number of original fowls, in which the fowls mated are not so closely related as in inbreeding; line breeding is really a modified form of inbreeding. Line breeding is often continued for a number of years without the introduction of new blood into the

flock, but in such cases great care is taken to breed from only the healthiest and most vigorous members of the flock. To maintain the vitality of the flock, only mature hens in their second or third year of laying are bred from. The success of any work in line breeding depends on the quality of the original fowls that are selected as breeders, and the judgment with which the later breeders are selected, both for their quality and for their vitality.

Inbreeding.—Inbreeding is a system of breeding in which the fowls mated are very closely related, being direct descendants of a very few original fowls. Inbreeding differs materially from line breeding on account of the closeness of the relationship of the fowls. The best fowls produced each year are mated with breeders of the previous season and with each other, even to the extent of pairing brother with sister. Inbreeding is carried on chiefly with a view to improving color in a flock. Shape may be improved by this system of breeding, but this is not usually the case. Loss of size and deterioration of shape are undesirable features that usually attend inbreeding, and the maintenance of vitality is also a serious problem. The undesirable consequences of inbreeding can be avoided only by the most careful attention to the details of breeding and to the selection of the breeding fowls. In most cases, the introduction of new blood into the breeding stock will be necessary.

Strain Breeding.—Strain breeding is a system of breeding consisting in breeding fowls of one variety in line for a number of generations from a few original fowls; this breeding must also be conducted by one breeder, or his successors. A strain cannot be said to be established, even after three or four generations of breeding, unless the indications are plain that the original fowls selected for the foundation of the strain have been able to transmit their characters through the series of generations, and also to cause the production of offspring of better quality than themselves.

From the preceding statements, it is evident that a valuable strain can be produced only by the most careful selection of the foundation stock, and the most skilful breeding during the succeeding generations. Chance breeding cannot be relied on to produce satisfactory results.

Cross-Breeding.—Cross-breeding is of two kinds: breeding together of fowls of different breeds; and breeding together of fowls of the same variety but which come from different localities or from different strains. Most commonly, cross-breeding is understood to be the mating together of fowls of different breeds, such, for instance, as a Plymouth Rock to a Wyandotte, or a Rhode Island Red to an Indian Game. This form of cross-breeding is often utilized in the production of broilers and roasters for market, the offspring from such crosses being useless for breeding together. The other form of cross-breeding, or of breeding for an out-cross, is usually practiced in the breeding of poultry for exhibition, and for the purpose of introducing new blood

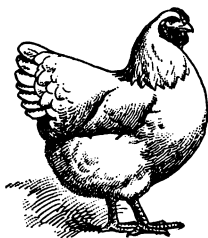

WHITE WYANDOTTE

into a strain to improve vitality.

Methods of Mating.—Mating is the act of pairing a male and a female for the purpose of producing offspring. The two general methods of mating are single mating and double mating. Single mating consists in mating together a male and a female.

When fowls are mated for the production, from the same pair, of both male and female offspring fit for exhibition, the process is called *single mating*. This is the method of mating commonly practiced in the mating of fowls of most varieties. This method of mating does not, however, produce the best results when the production of the most delicately marked fowls of the varieties most difficult to produce is desired.

The mating of one pair of fowls for the purpose of producing male offspring fit for exhibition and another pair for the production of female offspring fit for exhibition is called *double mating*. This is practiced to a great extent in the production of Barred Plymouth Rocks, Brown Leghorns, partridge-colored fowls of all breeds, and to some extent in producing fowls that have penciling or lacing in their plumage. In double mating, great care is taken to see that the male and the female blood lines are kept separate, for if blood lines are crossed, color will be injured.

ENEMIES AND DISEASES OF POULTRY

ENEMIES

GENERAL REMARKS

A *parasite* is any creature that secures the whole or part of its living from another. The parasites that attack poultry are insects.

Methods of Infestation by Parasites.—Poultry become infested with parasites in many ways, and it is advisable for the poultryman to keep a close watch to prevent such infestation. Some of the most common ways in which poultry becomes infested with parasites are: (1) by the introduction of an infested fowl into a flock; (2) by a hen infesting her chicks when they are incubated or brooded in a natural way; (3) by allowing infested fowls to roam at liberty; (4) by sparrows; (5) by the parasites crawling up on roosts that are not protected by safety appliances; (6) by the parasites dropping on the fowls from the ceilings of houses; (7) in nest boxes; (8) in dust baths.

Effects of Parasites on Poultry.—Parasites cause more disease, ill health, and death among poultry than all

other causes combined. The following are the principal specific effects resulting from parasites: (1) They reduce the vitality of poultry; (2) they lessen egg production; (3) they deduct from the table qualities of fowls intended for market poultry; (4) they interfere with the proper performance of the natural duties of incubating and brooding; (5) they cause the loss of parts of a fowl's body; (6) they infest poultry with other and additional varieties of parasites; (7) they infect poultry with fungous and bacterial diseases

Rapidity of Reproduction of Poultry Parasites.—The exact time required for poultry parasites to produce new generations cannot be stated definitely. Under favorable conditions, however, all kinds of poultry parasites are very prolific and will increase to an alarming extent. Salmon states that the third generation from a single louse may number more than 120,000, and all of these may be produced within a period of 8 wk. Such a rapid increase being possible, the result of introducing into a flock a fowl that is thoroughly infested with parasites can readily be surmised. Such a fowl is sure to do injury.

Poultry parasites multiply particularly fast in damp, filthy, unsanitary places—surroundings that are unfavorable to poultry even when not infested with parasites. Poultry parasites, however, will also develop rapidly in clean places if the air is allowed to remain hot and moist for any length of time.

PARASITES ATTACKING DOMESTIC FOWLS

The parasites that are found occasionally on domestic poultry are: Large chicken louse (*Goniocotes abdominalis*); lesser chicken louse (*Goniocotes hologaster*.) The *Goniodes dissimilis* and the *Goniocotes burnettii* are rarely found on fowls.

A louse that is sometimes found on fowls and which does considerable damage to the feathers when present in large numbers is the variable chicken louse, or feather louse (*Lipeurus variabilis*).

The parasites that frequently infest domestic poultry are: Common hen louse (*Menopon pallidum*); red mite, chicken mite, or red spider louse (*Dermanyssus gallinae*); itch, or scab, mite (*Cnemidocoptes laevis*, var. *gallinae*), scaly leg mite (*Cnemidocoptes mutans*).

The parasites infesting turkeys, peafowls, and guinea fowls, in addition to the common hen louse and the red mite are *Lipeurus polytrapezius*, *Goniodes stylifer*, *Goniocotes rectangulatus*, *Goniodes falcicornis*, and similar ones.

The parasites most commonly infesting water fowls are *Trinoton luridum*; *Lipeurus squalidus*, which is commonly found on ducks; *Trinoton lituratum*; *Ornithobius cygni*, which is commonly found on geese; and *Docophorus cygni*, which is commonly found on swans.

The parasites most commonly infesting pigeons are: Common pigeon louse (*Goniocotes compar*), *Lipeurus baculus*, *Goniodes damicornis*, and two varieties of fleas.

INSECTICIDES

The substances that are used to kill insects are called *insecticides*. The three general classes of insecticides that are employed to kill the parasites that infest poultry are powders, liquids, and fumes. The powders have to be dusted on the bodies of the parasites so that the fine particles of the material will be drawn into the breathing tubes of the insects. These tubes are thus clogged, and the insect dies of suffocation. The liquids kill because they are corrosive or because they get into the breathing tubes of the insects and suffocate. The fumes employed kill because they suffocate.

All poultry parasites except mites can be kept under control, so far as their presence on the bodies of birds is concerned, by the use of insect powders. Insect powders, however, are not so efficient for destroying parasites about poultry buildings as liquid and fume insecticides. Insecticides containing arsenic, such as Paris green, or other deadly poisons, should never be used about poultry buildings, as they are likely to poison both poultry and attendants.

Powder Insecticides.—To be suitable for killing the parasites of poultry that can be destroyed by powders, a powder must be very fine—at least as fine as ordinary road dust—perfectly dry, and not possess any adhesive qualities. Many kinds of powders are used for destroying the parasites of poultry. They consist of substances that range from the most deadly poisons to the most harmless materials, and from ill-smelling powders to those that have no odor. No advantage is gained by using either poisonous or offensive smelling powders to kill the parasites of poultry, and they are dangerous both to the poultry and the person applying them.

Some of the many kinds of insect powders are mentioned and briefly described here because one or more of them can be found in any locality. The powders described do not include those that are specially prepared and sold in packages under a trade name. Any of the following powders may safely be used for dusting on poultry of all kinds.

Aniseed powder is made from the seed of the anise plant, which grows in many parts of Europe. This powder is suitable for use about young chicks, poults, ducklings, and goslings.

Pyrethrum powder is also commonly known as *Persian* or *Dalmatian* insect powder and as *Buhach*. It is usually sold by the pound in drug stores. This powder is commonly made from the dry flowers of certain species of chrysanthemums which are grown in Persia, Dalmatia, and neighboring lands, and in California. When pure, this powder is one of the very best powders that can be used for dusting into the plumage of fowls, both old and young.

Fine tobacco dust, which is a refuse from tobacco factories, is an effective insecticide. It is suitable for dusting into nests, and will destroy body lice. Tobacco dust has the disadvantage that it will stick to the skin of the fowls. It also has a disagreeable odor, which is intensified by the heat and moisture of the bodies of the birds.

Stavesacre seed powder is made from the seed of a species of larkspur that grows in Southern Europe. It is a poisonous substance, and delphinin, a poisonous drug, is made from this seed. When fine, this powder is a good insecticide.

Dry air-slaked lime makes an effective insect powder on account of its extreme fineness.

Road dust will answer as an insecticide when used alone, provided it is very fine. It is also used as a base to mix with finely ground powders to make insecticides. To make sure that road dust is fine enough to be valuable as an insecticide, it should be passed through a very fine sieve, similar to that used by druggists for separating the coarser from the finer particles in a powder.

Compound insect powders composed as follows will be found effective:

1. Fine road dust that has been carefully sieved and mixed with an equal quantity of *Pyrethrum*

powder. This will be very effective provided the *Pyrethrum* powder is pure and the road dust very fine.

2. Equal parts of air-slaked lime, tobacco dust, and fine dust from coal ashes. If very fine and dry, this mixture will be suitable for dusting into nest boxes or on the bodies of fowls. It may, however, adhere to the bodies of the fowls and cause irritation.

Liquid Insecticides.—Liquid insecticides are more effective for application to the interior of poultry buildings than powder insecticides, for the reason that they can be sprayed into all the cracks and crevices. When thoroughly applied, a good liquid insecticide will rid



WHITE LEGHORNS

a house of practically all the parasites that are in it. Some insects such as red mites can conveniently be exterminated only by the use of liquid insecticides. When liquid insecticides of any kind are used as either a spray or a paint, on poultry buildings, they should be allowed to soak into the wood and dry thoroughly before the fowls are permitted to go inside of the building. Liquid insecticides of some kinds may also be applied to the bodies of poultry.

Some liquid insecticides are applied by themselves without dilution or combination with any other material; in the form of an emulsion with other liquids; or with other materials in solution in them. A description of the principal liquid insecticides in use at the present time follows:

Creosote is widely used as an insecticide. It is also known in some localities as *crude carbolic acid* and as *creosote stain*. Creosote is a coal-tar product. It is not an expensive material and is usually sold in paint stores. In large quantities it can be purchased at from 40c. to 50c. per gal., and in small quantities at from 80c. to \$1 per gal. Creosote is used for shingle stains and as a wood preservative for many other kinds of woodwork. If it is desired to color the inside or outside of the houses to which creosote is to be applied, dry paint can be added to it. Creosote is the best liquid insecticide for spraying on the interior of poultry houses. Two or three applications of this material will rid any building or coop of insect vermin of all kinds.

Creosote bought at different times and in different places will not always be of the same viscosity or thickness. When very thick it may need to be diluted in the proportion of 1 part of creosote to from 3 to 4 parts of kerosene oil, in order to get it in the proper condition for spraying. Thinner samples of creosote may need to be diluted with only 2 parts of kerosene oil to make it suitable for spraying. For painting roost poles and nest boxes, the thinner kind of creosote is commonly used without any dilution; the thicker kind is usually

diluted with 2 parts of kerosene oil when used for this purpose. Roost poles may also be satisfactorily painted with a wash made up of equal parts of creosote and hot water. When roost poles and nest boxes are treated with this mixture, they should be allowed to dry in the sun before being put back in the house; when the roost poles are put back in the house their ends should be painted with a coat of the undiluted thick creosote. A mixture of $2\frac{1}{2}$ gal. of creosote, $2\frac{1}{2}$ gal. of water, and 1 lb. of washing soda will also make an effective wash for nests, roosts, and brood coops. If this is used hot and applied in a spray, its effectiveness will be increased.

After a house has been thoroughly freed of parasites, the roost poles and the interior of the nest boxes should be coated with one of the above mixtures of creosote once a week for a month, and occasionally thereafter. This work should always be done before noon so that the creosote will have time to dry before night.

Crude petroleum is an inflammable oily liquid from which a number of other oils that are used for commercial purposes are obtained by processes of refining. It is also called *coal oil*, *earth oil*, *mineral oil*, *natural oil*, *rock oil*, and *Seneca oil*. Crude petroleum is a dark brown to greenish liquid.

Kerosene is an inflammable oil distilled from crude petroleum or any mineral hydrocarbon. Kerosene is suitable for spraying the interior of poultry houses, but is not well suited for applying to the bodies of fowls. Inflamed eyes, blisters, and sore spots on the skin will result when kerosene is applied direct. It is absolutely unfit to use on the bodies of young chicks.

Bensine is a colorless, inflammable, and volatile liquid obtained from distillation of crude petroleum. While it is often used as an insecticide, it is dangerous to handle because of its inflammability.

Gasoline is also a colorless, volatile, and inflammable liquid obtained from the distillation of crude petroleum. It is dangerous to handle for the same reason that benzine is dangerous.

Turpentine is a product of such trees as the pine and other similar trees. It is much used in the making of paints and varnishes and also in medicine. It is inflammable and will irritate the skin.

Creoline, a liquid manufactured especially for use as an insecticide, is effective in killing the insect enemies of poultry. Creoline may be used in the interior of poultry houses diluted in the proportion of 3 fluid oz. of creoline to 1 gal. of water.

Carbolic acid is largely used in the destruction of poultry parasites. A solution made of $1\frac{1}{2}$ fluid oz. of carbolic acid to 1 gal. of water is strong enough for this purpose. Carbolic acid is sometimes added to whitewash so that sanitary conditions can be improved at the same time that an insecticide is applied. When used in this way, however, carbolic acid does not have as effective insecticidal properties as when it is used without whitewash.

Milk emulsion is usually first made up in a concentrated or stock solution, or cream solution as it is sometimes called, and then diluted just before it is applied. To make the stock solution, add 2 gal. of kerosene to 1 gal. of milk and churn or mix thoroughly with a force pump or other agitator. This stock solution should be diluted in the proportion of 1 gal. of the stock solution to 4 gal. of warm water. Crude petroleum, benzine, gasoline, or turpentine may be substituted for kerosene in this formula. Kerosene, however, can usually be purchased cheaper than the other liquids except crude petroleum.

Soap emulsion is also usually first made up in a stock solution and then diluted just before it is to be applied. To make a stock solution of soap emulsion, dissolve 1 lb. of hard soap in 1 gal. of hot water; when the soap has all dissolved and while the solution is hot, add 2 gal. of kerosene; mix thoroughly with a force pump or an agitator of some kind. When to be used for spraying the interior of poultry houses, this stock solution should be diluted in the proportion of 1 gal. of the stock solution

to 4 gal. of water. Crude petroleum, benzine, gasoline, or turpentine may be substituted for kerosene in this formula also.

Liquid lice killer is a name frequently applied to an insecticide made from kerosene oil and powdered naphthalene flakes or balls, in the proportion of 2 lb. of naphthalene to 1 gal. of kerosene. The can containing this solution should be covered so that the liquid will not leak out of it, and the solution should be agitated frequently by shaking. The solution should be allowed to remain in this can about a week, when it should be poured into another receptacle, so that another batch can be mixed if necessary. If 2 fluid oz. of creoline or of creosote are added to the clear solution, the effectiveness of the solution will be improved. The cans containing this solution should be kept in a temperature that never goes below 40° F. or the naphthalene will go out of solution and appear in flakes. The solution should be kept for about 24 hr. in a warm place before it is used, so that it will be at about 70° to 80° F. when it is applied. This solution should never be kept close to a fire, nor should any attempt be made to heat it over or near a fire, as it is inflammable. This liquid lice killer may be used for either painting or spraying the interior of poultry houses and brood coops.

Compound liquid insecticides made up according to the following formulas may be used with safety on the bodies of young chicks: 1 oz. of oil of sassafras to 2 or 3 oz. of sweet oil; 1 oz. of oil of aniseed to 3 oz. of sweet oil.

Lard can also be rubbed on the heads and throats of young chicks for use as an insecticide.

Whitewash is not effective as an insecticide unless it is mixed with carbolic acid in the proportion of 1½ fluid oz. of carbolic acid to 1 gal. of whitewash. Even when containing carbolic acid, however, it cannot be depended on to kill mites. If applied hot, the effectiveness of this mixture will be increased. Whitewash applied by itself will not kill insects unless it happens

to so completely cover them that the creatures will drown in it. Whitewash can be recommended to help maintain sanitary conditions about a poultry house, but unfortunately when it is used it often gives the poultryman a false sense of security against parasites and frequently causes him to neglect the proper measures to exterminate the insect enemies of his poultry.

Fume Insecticides.—Fume insecticides are produced by burning various substances. Fumes that are extremely poisonous should not be used for killing poultry parasites, as there is no necessity for their use, and persons, animals, and the poultry may be accidentally exposed to them. The following can be recommended as effective on parasites, and not necessarily fatal to other creatures if inhaled in small quantities, though they will prove fatal to any person, animal, or bird if inhaled in sufficient quantities:

Sulphur fumes can be produced by burning sulphur. Either lump sulphur, which is frequently called brimstone, sulphur candles, or powdered sulphur can be used for this purpose. The powdered sulphur will produce fumes more rapidly than the lump sulphur. The sulphur should be placed in an iron pot or pan to avoid fire and should be moistened with alcohol or some other inflammable liquid to make it burn more freely.

Tobacco fumes may be produced by burning any kind of tobacco. Such fumes are usually produced by burning the waste leaves or stems of the tobacco plant, as these can be purchased cheaply. The tobacco stems or leaves should be placed in an iron receptacle of some kind to avoid the danger from fire and should also be moistened with alcohol or some other inflammable liquid to make it burn quickly.

Creosote fumes or *liquid lice-killer fumes* are sometimes used for killing the parasites on a few fowls confined in a small space.

INSTRUMENTS FOR APPLYING INSECTICIDES

Powder Guns.—Insect powders can be applied by hand, but they are more effectively applied by the use of powder guns. A small powder gun is shown in Fig. 1. This will answer when only a few fowls are to be dusted, but where there are a large number of fowls to dust, a larger powder gun will be required. A bellows powder gun is shown in Fig. 2. With this it will be

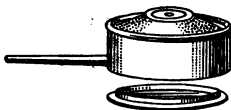

FIG. 1

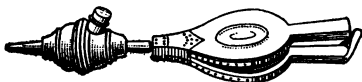

FIG. 2

possible to dust a large number of fowls in a short time. This can be used at night by going about among the fowls and quietly inserting the point of the gun among the feathers of the fowls while on the roost, and in this way dust them thoroughly.

Sprayers.—Liquid insecticides can be most effectively and economically applied in spray form. Where there is only a small surface to go over, a small hand-spraying outfit similar to that shown in Fig. 3 will answer.

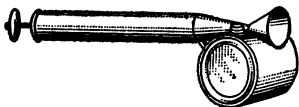

FIG. 3

Where a large amount of surface has to be covered, a spraying outfit like that shown in Fig. 4 will be found more convenient. There are many makes of these com-

pressed-air sprayers on the market. Those with galvanized-iron receptacles for the liquid will answer for

spraying insecticides but will not prove satisfactory for spraying Bordeaux mixture on plants. By using spray pumps to apply insecticides, a large quantity of liquid is saved as compared with applying them by means of a brush, and the insecticide is also applied more effectively. When applied in a fine spray, it penetrates into the cracks and crevices in the building and forms an even covering over the flat surfaces.



FIG. 4

KILLING OF PARASITES

A constant watch must be kept for parasites, because from the moment chicks come from the shell they are menaced by insect vermin. The most practical way of meeting the problem is continually to practice preventive measures.

If poultry parasites are allowed to become numerous they will sap the vitality of the fowls, and although the parasites themselves may be gotten rid of, it will be impossible to restore the physical condition of the fowls. For application to poultry houses, liquid and fume insecticides are most effective, but usually liquid insecticides are the more convenient to apply. Powder insecticides are ordinarily effective on the bodies of fowls, but it must be borne in mind that they will not kill all classes of parasites.

Houses that are maintained in a cleanly condition, well lighted with sunlight, and free from dampness will never be badly infested with parasites, if they are given regular sprayings with some good liquid insecticide. Nothing can take the place of sanitary conditions as a preventive measure, but sanitary conditions combined with regular spraying is most effective.

Prevention of Infestation by Fowls From Other Flocks.
To avoid the chance of carrying parasites into a house

or to a flock that is free from parasites, all fowls brought in from other flocks should be kept in a sort of quarantine by themselves and specially treated for a number of days. The place of quarantine should be a small coop or cage that is free from parasites. For a period of about 10 da. some effective powder insecticide should be frequently dusted into the feathers of such fowls. To do this, the fowl should be held in one hand by the shanks, with the head hanging down, and the insect powder should be worked into the feathers of every part of the body and down on to the skin with the fingers of the other hand. In especially bad cases, a thorough washing should follow this dusting.

Method of Ridding a Poultry House of Parasites.—The thorough cleaning of a poultry house that has become badly infested with parasites is a difficult problem and drastic measures are required. If the building is a cheap affair, like a small coop, it is often best to burn it, but burning would be too expensive in the case of a large poultry house. Before attempting to clean a poultry house, all the fowls should be removed to other quarters, dusted with insect powder and kept by themselves until the house cleaning is completed. To get a badly infested poultry house in good sanitary condition and free from parasites will require several days. The following treatment will be found effective, but in exceptionally bad cases a repetition of the treatment may be necessary.

1. The house should be thoroughly fumigated. After removing the poultry, stop up every crack and crevice, so that the fumes will not escape. A number of substances can be used for fumigation, but sulphur and tobacco are the ones that can be recommended. If either of these are used they should be burned in some metallic receptacle such as an iron pot or kettle, to avoid fire. If these substances are moistened with alcohol or some other inflammable material they will burn more freely. Whatever material is burned to produce the fumes, enough of it should be used so that the interior of the

building will be filled with enough fumes to darken it. The building should be kept tightly closed for 24 hr.

2. The interior of the house should be dusted with dry air-slaked lime. To do this a person should take a bucket, bag, or pailful of the fine lime and start at the end of the house farthest from the door, and walk slowly backwards toward the door, scattering the lime with the right hand in the same way that seed is sown. The lime should be thrown against the ceiling, side walls, nest boxes, roosting places, etc. The air should be filled with a cloud of lime dust. This dust will settle gradually into every crack and crevice of the house. While the lime dust is being scattered, the house should be closed as tightly as possible. About a half bushel of lime dust will answer for a poultry house 20 ft. wide and 40 to 50 ft. long. A thin cloth that the operator can see through should be tied over the eyes, nose, and mouth to prevent the lime dust from getting into them. Any parasites that may have escaped the fumes of the sulphur or tobacco will more than likely be killed by the lime dust. The house should be closed again for 24 hr. to allow the lime dust to settle thoroughly.

3. The house should then be brushed or swept clean. The ceiling, walls, floor, and every appliance and fixture inside the house should be carefully brushed. No dust or dirt should be left. The straw from the nest boxes, and the straw and dirt from the floor should be taken outside, saturated with kerosene, and burned. After all that will burn has been burned, the rest should be buried deep in the ground.

4. The house should be thoroughly sprayed both inside and out with one of the liquid insecticides described. Creosote and liquid lice killer are to be preferred, in the order named. The liquid insecticide applied at this time should be allowed to dry thoroughly.

5. A second application of the liquid insecticide should be made to the interior of the house, the nest boxes, and roosting poles before the fowls are allowed

to return. This application should be made on the morning of the day the fowls are to be returned to the house; after the liquid has dried sufficiently, fresh straw should be placed in the nest boxes.

6. The fowls should be thoroughly dusted with insect powder immediately before they are allowed to return to the house. They should be returned to the house at dusk with the powder in their feathers so that they can roost the first night without shaking out the powder.

7. Sanitary conditions must be maintained continually in the house and a strict watch must be kept for the appearance of parasites, both on the fowls and about the house. If this is not done the house is likely to be reinfested with parasites. If parasites appear the house should be thoroughly cleaned and sprayed again. To maintain cleanliness the interior of the buildings, the side walls, ceilings, roosting places, nest boxes, etc. should be brushed frequently with a stiff broom, and all filth should be systematically removed from the floor before it has a chance to accumulate in any quantity.

ANIMALS DESTRUCTIVE TO POULTRY

Nearly all flesh-eating animals attack poultry when the occasion offers. The animals that do the most harm to the average poultry flock are wildcats, raccoons, opossums, skunks, weasels, minks, rats, dogs, and cats. It is said that the tiger of India and the smaller members of the feline family hunt the peafowl and the pheasant. Where foxes are found in the neighborhood they will also attack poultry. The great proportion of animals destructive to poultry hunt by night, and hence if all openings in the poultry houses are closed with wire netting, practically all of the animals most likely to be attacked would be secluded.

For the capture or destruction of animals destructive to poultry the usual spring and box traps are used.

BIRDS DESTRUCTIVE TO POULTRY

It is difficult to determine just which birds are destructive to poultry, because many birds that live on rodents, such as field mice, rats, etc., will attack poultry when short of other food. As a general rule, however, birds are not very destructive to poultry, because even the birds that attack domestic fowls the most frequently come far from being the worst enemies of poultry. One rat, for instance, will often destroy more chicks in a single night than a pair of hawks will carry off in a month, and the insect enemies of poultry do more damage than all other agencies combined.

Falcons, hawks, and owls are the principal birds of prey that attack poultry and may be separated into four classes, grading from the least destructive to the most destructive as follows:

The hawks and owls least destructive to poultry are:

1. The large rough-legged hawk, the squirrel hawk, and the white-tailed, Mississippi, swallow-tailed, and English kites. These birds will not disturb or hunt for poultry so long as they can find a satisfactory supply of other food to supply their wants. They are generally considered as being entirely beneficial to mankind.

2. According to Dr. A. K. Fisher the majority of hawks and owls are usually beneficial to mankind, but will often kill poultry when the occasion offers. He names the following as belonging to this class: Marsh hawk, Harris's hawk, red-tailed hawk, short-tailed hawk, white-tailed hawk, red-shouldered hawk. Swainson's hawk, short-winged hawk, broad-winged hawk, Mexican black hawk, Mexican goshawk, sparrow hawk, barn owl, long-eared and short-eared owls, great gray owl, western owl, Richardson's owl, screech owl, snowy owl, hawk owl, and other smaller species.

3. Fisher also classes the following birds as doing about as much good by destroying other creatures as they do harm by destroying poultry: Golden eagle, bald eagle, pigeon hawk, Richardson's hawk, falcons, and the great horned owl.

4. Birds that are very destructive to poultry and not of much benefit through destroying other creatures are: Gray falcon, duck hawk, sharp-shinned hawk, Cooper's hawk, and goshawk.

The birds that are classed as least destructive to poultry subsist almost entirely on rodents that destroy field crops and trees, but notwithstanding the fact that they prefer this kind of food they cannot be trusted where young chicks are being raised. Under starving conditions all of these birds will kill the young of chickens, turkeys, and water fowls. The sparrow hawk, the smallest and most beautiful of all the above birds, lives almost entirely on insects and field mice, but will, if tempted by their presence, kill young chicks.

In addition to the above birds, ravens, blackbirds, and crows will destroy young poultry. It is not unusual for the raven and the crow to fly away with chicks that are 2 or 3 wk. old. This, however, will occur only where the poultry have the range of the farm near the nesting places of these birds.

Well-built houses are a good protection against birds of prey. Scarecrows and hawk traps are also sometimes effective. The presence of a few guinea fowls and a well-trained dog will often keep a fair-sized farm free from birds of prey. Neither guinea fowls nor dogs will do any harm to birds of prey, but the guinea fowls will make a loud outcry whenever birds of prey appear, and



WHITE MINORCA

the dog that is trained for the purpose will bark at the noise and will chase the birds of prey away.

DISEASES

GENERAL REMARKS

A *disease* is any derangement of a living organism, but the term *ailment* is usually applied to slight disorders. Though there are many diseases of poultry, and some serious ones, comparatively few fowls are diseased, when the large numbers of fowls in the country are considered, and poultry that is kept in sanitary quarters and has proper food is the least likely to become diseased. Hence, the importance of preventive measures.

Poultry in poor health will exhibit a dull, sluggish, and listless appearance, which is the strongest evidence of a lack of vitality, and will go to roost early and remain there in the morning until long after the other fowls are out looking for food. When they do leave the roosts they will walk about as if they were not strong enough to drag their legs and feet after them. Fowls in poor health will have a bloodless appearance, will have an absence of healthy brightness in their eyes, faces, combs, and wattles, and will show a general lack of condition, which is always accompanied by a lack of appetite and a failure to assimilate properly the food they eat. Hens in poor health will lay but few eggs. Whenever fowls have had their vitality reduced so that they exhibit the symptoms described they will be susceptible to the attacks of all kinds of diseases.

There are few symptoms that are of practical value in the diagnosis of the diseases of poultry, for the reason that many symptoms are common to several different diseases. A few general symptoms are, however, of value. Fowls that are diseased become listless; they are inclined to stay apart from other fowls, and will stand in out-of-the-way places or beside a fence sunning themselves, their heads hanging and their feathers

ruffled. It is natural for fowls to sun themselves, but there is a marked difference between the healthy fowl basking in the sun for recreation and the sick fowl standing there in the hope of warming its body. Disease in poultry is always accompanied by a loss of appetite and generally by frequent voidance of the bowels.

The temperature of normal fowls ranges from 106° to 107.5° F., but the temperature of fowls is rarely taken, chilliness being usually accepted as an indication of fever. The heart beat of fowls is quite rapid, varying from 110 to 140 per minute. The rapidity, however, is not of so much importance as the regularity. The normal breathing rate of fowls is from 50 to 60 respirations per minute. When the respiratory organs are diseased, the respirations are quickened. The regularity or irregularity of the heart beat or of respiration will be plainly heard if the ear is placed against the backbone or the ribs.

Preventive measures are the best treatment for poultry troubles. The fowls should be handled in such a way that they will contract as few diseases as possible, and the slightest ailment should be treated before it has a chance to gain headway. This requires constant attention, but this is the only way to success.

None but very simple treatment is ordinarily necessary for poultry, and any ailment that will not yield readily to simple treatment is usually so serious that even if a fowl is enabled to recover from it, the results will not be satisfactory, for the vitality of the fowl will be seriously impaired. Hence, the practical poultryman, except in the case of particularly valuable fowls, usually kills any ailing fowls that do not recover quickly from simple treatment.

Medicine is most satisfactorily administered to a flock of fowls by being fed mixed in a warm or slightly warm mash. Pills are usually the most convenient form in which to administer medicine to individual fowls. When liquids are poured down a fowl's throat care should be taken to avoid strangulation.

FUNDAMENTAL PRINCIPLES OF TREATMENT

There are a few fundamental principles of treatment that it would be well for every poultryman to have continually in his mind. Morse's maxims cover this ground so well that they are given here:

"Clean out by means of Epsom salts, administered in an evening mash, estimating one-third of a teaspoonful to each adult bird. When disease is raging this may be practiced with the sick two or three times a week until there is an abatement of the outbreak. Even the well birds should receive one such dose at the beginning of an outbreak of disease. After disease has swept through a flock, until one is certain that it has been entirely eradicated, it is well to give the flock at least one dose monthly during the cooler weather and twice a month during the heated term.

"Clean up the poultry houses by sprinkling powdered, air-slaked lime over the runs, dropping-boards, and floors. This should be practiced at the time of giving the salts, as the lime will destroy the parasites that are deposited in the droppings.

"Clean the water supply by adding to the drinking water enough permanganate of potash to turn the water a claret red; that would ordinarily be as much as you can spread on a silver 10c. piece to the gallon of water. Instead of this, iron sulphate may be added in the proportion of 10 gr. to 1 gal. of water. Or, instead of either, 1 teaspoonful of strong carbolic acid (not crude) may be added to 1 gal. of water. This should be practiced constantly during the prevalence of disease. Healthy fowls not threatened with disease do not need it.

"Clean eggs by dipping them in 90% alcohol, just before placing them in the incubator. Instead of the alcohol, a 3% solution of some good coal-tar disinfectant may be used, with this exception, that instead of dipping, as in the use of alcohol, they should be wiped with the coal-tar disinfectant. The purpose of this rule is to remove from the shell of the egg the various

contaminating microbes that are deposited on the shell in its passage through the cloaca.

"By all means furnish your poultry with nothing but clean food. Moldy food is certain to produce disease and death. However, circumstances sometimes arise in which it appears impossible to avoid the use of food that has been exposed to the conditions favorable to the production of mold. In such circumstances, destroy the mold by the application of strong heat. Do not think that this suggestion is a happy thought to permit you to lessen your expenses by buying seconds, thirds, etc. in the feed line. If you practice it, it will be to your certain loss. An emergency suggestion is never a rule to be regularly carried out.

"Clean incubators and brooders by thoroughly scrubbing them with hot water and common soap. This practice, alone, has helped to cut down the cases of white diarrhea and brooder pneumonia. Having once used the incubators and brooders, remember that danger, disease, and death lurk in them until they are disinfected.

"Breed from the youngest females consistent with the needs of good breeding. Investigators have recently shown that there are fewer cases of egg infection by bacteria in the eggs that come from virgin pullets. A study of the anatomy of fowls and the physiology of fertilization makes plain at once how all kinds of bacteria may be introduced into the egg tube by the male bird in the act of copulation. Once in the egg tube it is not difficult for the bacteria to eventually reach the ovary and thus we may have infection of eggs in the ovary and in the upper part of the egg tube."

SIMPLE REMEDIES FOR POULTRY

Every poultryman should have at hand a few simple remedies that may be safely used in the treatment of poultry diseases and ailments. Many of the common remedies kept in the home for use with children will be valuable for poultry. The following materials are all convenient for the poultryman to have on hand:

Epsom salts, called also *bitter salt*, is a white, hydrated, crystalline salt known chemically as *magnesium sulphate*. It is used as a purgative in doses of $\frac{1}{8}$ teaspoonful to each fowl.

Castor oil is a thick yellowish-white oil expressed from the castor bean. It is used as a purgative.

Olive oil, called also *sweet oil*, is an oil expressed from the ripe fruit of the olive. It serves the purpose of butter in some countries, but in most parts of the civilized world is used chiefly in salad dressings. Olive oil is the most nearly perfect laxative for use with poultry, as it is both healing and nutritious, thus possessing an advantage over castor oil. A tablespoonful of olive oil can be safely administered.

Camphor is a gumlike, translucent, crystalline compound with a penetrating, fragrant odor; it is distilled from the wood and bark of the camphor tree. It may be used as a medicine for poultry to allay irritation, as in colds and in cases of slight diarrhea.

Copper sulphate, called also *bluestone*, is a blue crystalline substance that is used as an astringent and stimulant, but not more than from $\frac{1}{8}$ to $\frac{1}{4}$ gr. should be administered more than once a day to any fowl.

Iron sulphate, called also *copperas*, is a green, crystalline substance that is used for the same purpose as copper sulphate and can be administered in doses of $\frac{1}{4}$ to $\frac{1}{2}$ gr.

Douglas mixture is used as a tonic for both poultry and pigeons, and is made by mixing $\frac{1}{2}$ lb. of iron sulphate with 1 oz. of sulphuric acid dissolved in 2 gal. of water. This may be used in the drinking water—2 tablespoonfuls of the mixture to each pint of water.

Table salt is sparingly used to season mash foods for poultry. A large quantity of salt will kill poultry, and it is better to give them none than too much. Less salt should be used to season food for poultry than is needed for human beings.

Rhinitis tablets, half strength, are an excellent remedy for a cold in its early stages. They are given to

poultry that have slight colds—two tablets two or three times a day for from 1 to 3 da.

Homeopathic remedies are used by many poultrymen for their poultry with satisfactory results. Such remedies should be given to poultry in quantities about as recommended for children.

Healing powders for applying to sores of any kind are useful to have on a poultry establishment. Equal parts of burnt alum and zinc oxide; or zinc oxide, powdered magnesia, and Venetian red are effective for this purpose. Burnt alum and the mixture of burnt alum and zinc oxide are excellent for use on any kind of sores. The zinc oxide and the powdered magnesia are very healing and painless. The Venetian red is slightly caustic and may be used where a light cauterization is needed.

Hydrogen peroxide, a clear solution that looks like water, is useful for cleansing and disinfecting ulcers or other sores on poultry.

Paraffin oil is a mineral oil derived from petroleum. It may be used for relief in cases of scaly leg and bumblefoot and may be applied to injuries of the shank, but should not be applied to the skin of the body or to the feathers.

Ointments are sometimes needed for irritations of the skin. Fresh zinc-oxide ointment is useful for this purpose, but when it becomes rancid it is unfit for use. An ointment made of equal parts of glycerine and rose water mixed in a mortar with zinc oxide until the whole assumes a thick mass, may also be used.

Iodine, turpentine, creoline, zenoleum, and tincture of iron are effective for destroying warts on poultry.

Tonics for preventing illness should never be given to poultry. Fowls in good health do much better without them. A tonic for young or half-grown chicks that have been weakened from any cause may be given in pill form according to the following formula: 2 dr. of iron citrate and 30 gr. of quinine sulphate, mixed into a mass with sirup of gum arabic so as to make

enough for 60 pills. One of these pills may be given night and morning for 3 da.

AILMENTS AND TREATMENT

Colds, Canker, Catarrh, and Roup.—The most common ailments of fowls are colds, canker, catarrh, and roup. All of these troubles are likely to come from exposure to damp or cold at seasons of the year when the temperature rises and falls quickly. Fowls are just as likely to take a cold in July and Aug. as in midwinter; they are especially likely to take cold on rainy days in the summer when they go to roost with wet plumage.

As a matter of fact, colds, canker, catarrh, and roup are often merely stages of the same disease. A cold may begin by a slight discharge from the nostrils, accompanied, perhaps, by watering of the eyes. Canker and catarrh, which are inflammations of the mucous membrane, are mild forms of diphtheria in which patches may grow on the inside of the throat and on the tongue or at the opening of the windpipe. These conditions follow one another quickly, unless prompt attention is given to the first symptoms of cold. The earlier forms of the disease do not seem to be contagious, but roup is contagious.

So many remedies are used in the treatment of these diseases that it is difficult to choose between them. The best remedy of all, perhaps, is permanganate of potash administered in the drinking water. The bathing of the head, face, throat, and nostrils with warm water in which some antiseptic solution is mixed, and the maintenance of perfect cleanliness in their surroundings is also advisable. The giving of internal remedies is very unsatisfactory, and any attempt to cure fowls afflicted with roup by any such means is almost useless. Fowls badly affected with roup should be promptly killed, their bodies buried, and the premises cleaned and disinfected with creosote or some other similar material. Permanganate of potash should be given to

the rest of the flock in their drinking water. A saturated solution may be made by placing 1 oz. of the crystals of permanganate of potash in a 2-oz. bottle of water. One teaspoonful of this saturated solution will be sufficient for 1 gal. of drinking water. A warm mash with a little ginger and red pepper added as a tonic may also be given with advantage.

Gapes.—Gapes is a disease caused by parasites or gape worms growing and adhering to the inner lining of the windpipe. This causes the chicks to gasp for breath; they open their mouths wide and sneeze or cough in an effort to throw the parasite out of the windpipe.

Among the remedies used for this is the feeding of asafetida, garlic, or onion tops in soft food. A teaspoonful of powdered asafetida to a pint of food will be plenty of this. Garlic and onion tops as much as they will eat will not injure them. Another means of relief is to introduce a feather down the throat and into the windpipe, the point of the feather being dipped in sweet oil before being introduced to the windpipe.

Bronchitis.—Bronchitis is a disease of the lining of the air tubes. Fowls that take cold are apt to have irritation of the bronchial tubes. When this becomes aggravated a rattling in the throat is apparent. Treatment is difficult. One drop of tincture of aconite may be given every hour until four or five doses have been administered. The fowl should be fed on warm bread and milk or a warm mash. When the rattling in the throat becomes aggravated there is but little chance for relief. The use of pills made of iron, quinine, and strychnine of the same strength that would be given to a 10-yr.-old child may be administered one each morning and evening.

Diseases of the Intestines.—Diseases of the intestines are caused by improper feeding, poorly kept or unsanitary houses, yards, and buildings, or long-continued exposure to damp and cold. These intestinal irritations cause diarrhea, dysentery, and like ailments, which may bring about what is known as *going light*. The

only safety against such ailments is perfect cleanliness, protection from cold and damp, and proper feeding.

Fowls that are attacked with looseness of the bowels or diarrhea may be treated by separating them from the rest of the flock, cutting off their supply of green food, and giving them water to drink in which a teaspoonful of tincture of iron has been mixed in each quart of water, feeding them warm mash composed of either stale bread, ground oats, and wheat bran equal parts, or of ground oats, wheat middlings, and wheat bran equal parts, either to be moistened with hot milk or hot water and seasoned with a teaspoonful of red pepper to each quart of mash.

Of recent years the scourge of white diarrhea has spread throughout the world. Some persons claim that nearly one-half of all the little chicks hatched are lost through this ailment. Whether or not so large a percentage of all chicks hatched die from this disease, it is a fact that entirely too many die in this way and that nearly all of the little chicks that die of looseness of the bowels have white diarrhea. The symptoms of white diarrhea are unmistakable. It usually attacks little chicks within the first week after they come from the shell. They shiver, hang down their wings, close their eyes, and stand about and peep in a most painful manner, and the discharges from their bowels is like a mixture of milk and lime. Other kinds of diarrhea and looseness of the bowels may be caused by cold, exposure to damp, or eating food that ferments in the bowels. Diarrhea from these causes does not make little chicks nearly so sick as does white diarrhea.

The cure for all these troubles is care and management. If little chicks are exposed to too much heat under the brooder or are chilled at night under the brooder, if they run out in the damp and wet and take cold, or if any of them eat bad food they are almost certain to be afflicted with looseness of the bowels. This can be cured or prevented by avoiding the troubles that cause the ailment and by a system of perfect sanitation

and cleanliness and the feeding of proper kinds of food. Looseness of the bowels of this kind can usually be cured by feeding equal parts of bread crumbs and rice boiled in milk. If there is sufficient moisture in the rice to moisten the bread, no more moisture is needed. If a little more moisture is needed, use hot milk. This treatment can be safely given to all little chicks troubled with looseness of the bowels. It will not hurt the chicks with white diarrhea. There is, however, no known cure for little chicks that are afflicted with white diarrhea.

Diseases of the Legs and Feet.—*Leg weakness, rheumatism, and gout* are troubles that cause lameness in fowls. Lameness may also come from corns or bumblefoot. Rheumatism and gout are often called leg weakness, although the leg weakness may be due to any one of a number of causes, as for instance too high a temperature in the brooder, to the chicks being kept too long on board floors, to insufficient nutrition, or to a lack of bone-forming material in the food. In most cases dietetic and hygienic treatment will prove sufficient.

Rheumatism and gout are kindred diseases caused by the fowls being exposed to dampness and by being shut up in badly ventilated houses. In fact, nine-tenths of all poultry troubles come from damp and unsanitary houses; if the houses were kept perfectly clean, dry, and free from insects, fowls would have but few ailments. There is no cure for rheumatism and gout, and scarcely any relief.

Scaly leg is a disease of the shanks caused by little mites that come from damp and filthy conditions. The mites get under the scales on the shanks and toes and cause swellings on these parts. Scaly leg may be quickly cured if treated at the beginning, but it is hard to eradicate at an advanced stage. It may be treated by rubbing the shanks thoroughly each day with an application of lard and kerosene until the growths are cleaned off. The most effective way of dealing with the trouble is to sell off the afflicted fowls for market

poultry and put the houses and surroundings in a sanitary condition.

Bumblefoot is an ulcer on the bottom of the foot of a fowl and is usually caused by a bruise. It may be treated by applying some kind of ointment or healing salve or by cauterizing with strong iodine or a saturated solution of permanganate of potash.

Chicken Pox.—Chicken pox is an ailment that comes usually in the fall of the year. The first appearance is noticed from the little black specks growing on the face and eyes, usually of young fowls. These continue to grow until they close the eyes completely and the fowls die of starvation, because they cannot see to eat. This ailment is the most prevalent in warm or tropical climates, where it is called sorehead. Frequently the entire head becomes raw, and when in this condition the fowl is so afflicted with flies, bugs, and mosquitoes that it is almost eaten up. The only treatment to be relied on is cleanliness and the bathing of the afflicted parts with a 5% or a 10% solution of creoline in water.

Bad Habits.—Egg eating and picking of sore places on the bodies of one another are bad habits acquired by fowls kept in confinement with nothing to do. There does not seem to be any remedy for these bad habits when they are once acquired. In some instances they may be checked by transferring the fowls from place to place or by giving them perfect freedom.

POULTRY JUDGING

METHODS OF JUDGING

In America there are three methods of judging: (1) By the *official score card* of the American Poultry Association; (2) by the *decimal score card*; and (3) by *comparison*.

The practice of judging by score card was begun and has continued in the United States and Canada ever since the compilation of the first Standard by the American Poultry Association. A few shows that are held during Nov. and a large number that are held between Dec. and April are judged by the score-card method. The shows that are held from April to Nov. are judged by comparison. The score-card method of judging has been recognized by the American Poultry Association since its origin.

The decimal score card was introduced by I. K. Felch in 1890, and since that time both the official and the decimal score cards have been used. Although the decimal score card has never been recognized by the American Poultry Association, its use continues and its advocates are increasing in number.

Although comparison judging has been used for so long in the placing of awards, in fact, much longer than the score-card method, it did not have the sanction of the American Poultry Association until 1904. Judging by comparison is practiced each year at all shows held prior to Nov. 1 throughout the United States and Canada. Nearly all the larger exhibitions are judged under the comparison system.

The advantages of each method of judging depend on the ability of the judges accurately to determine how nearly the fowls under consideration approach the requirements of the standard. The use of the score card is considered of the greatest advantage to the amateur,

OFFICIAL SCORE CARD OF THE
Fancier's Poultry Association

DATE _____ VARIETY _____

OWNER _____ SEX _____

ADDRESS _____ BAND NO _____

ENTRY NO _____ WEIGHT _____

	Shape	Color	Remarks
Symmetry _____			
Weight or Size _____			
Condition _____			
Head and Beak _____			
Eyes _____			
Comb _____			
Wattles & Ear Lobes _____			
Neck _____			
Wings _____			
Back _____			
Tail _____			
Breast _____			
Body and Fluff _____			
Legs and Toes _____			
*Hardness of Feather _____			
†Crest and Beard _____			

Total Cuts _____ Score _____

*Applies to Games and Game Bantams

†Applies to Crested Breeds

_____ Judge

_____ Secretary

FIG. 1

who gains knowledge by a careful study of his own fowls in comparing them with the decisions of the judge, which are shown in detail on the cards, which go to the exhibitors. Comparison judging, however, is equally beneficial, provided the exhibitor is present and can understand the reasons for the various awards and rejections. Comparison judging becomes of more general use in neighborhoods where poultry shows have been held annually for a considerable length of time. Score-card judging is in more common use in localities where the practice of holding poultry shows is in its infancy. More shows are judged by score cards throughout the United States and Canada than are judged by comparison. Comparison judging is really an advanced system of judging that can be employed by those who are familiar with the distinctions considered of the greatest importance.

SCORE CARDS

A copy of the official score card of the American Poultry Association is shown in Fig. 1. The only change needed to make this score card local is to print at the top in place of "Fancier's Poultry Association," the name of the local association using it. This card gives a list of the parts of a fowl in respect to which it is to be scored, and a space is provided for noting the score for each part. A definite number of points is assigned to each part, the total number of points indicating perfection in all parts being 100. The figures scored after each part indicate the degree to which it approaches perfection according to standard requirements, and the total score shows how closely a fowl approaches perfection in all respects, which is 100 points. This method is a mathematical analysis of the defects found in a fowl, and enables a judge to make a discount for each.

The score card was designed for judging poultry at exhibitions. The object was not only to decide the

THE DECIMAL SCORE CARD

Date _____

Breed _____

Sex _____ Entry No. _____

Coop No. _____ Ring No. _____ Weight _____

Owner or Exhibitor, Copyright by I. K. Felch	Each Section 10 Points	CONDITION WEIGHT or SIZE		DIRECTIONS FOR USING THIS CARD.—To cut for weight, comb, head, legs, check (X) the features defective and cut in the column. For shape, make cut above the dotted line. For color, below the line. Shape being more defective than color, cut in space for shape, but low enough to include the dotted lines. Color being the greater evil, commence the figure just above the dotted line and carry deep down into color space. This secures despatch in use for exhibitions.
	COMB, or CREST AND COMB			
	HEAD AND ADJUNCTS	BEAK EYE EAR LOBE WATTLES		
	NECK	Shape Color	
	BACK	Shape Color	
	BREAST	Shape Color	
	BODY and FLUFF	Shape Color	
	WINGS	Shape Color	
	TAIL	Shape Color	
	LEGS and TOES	Shape Plum'g Color		
Total Defects			Score	

_____ judge
 _____ President
 _____ Secretary

FIG. 2

awards, giving the highest scores and the best prizes to the fowls least defective, but to give every fowl exhibited a rating in terms of the standard requirements and in comparison with competing fowls of the same sex and variety.

This system can be used also by fanciers and breeders as a guide in computing values in sale fowls, and in selecting breeding and exhibition fowls.

A copy of the decimal score card is shown in Fig. 2. This card provides ten divisions for the features in respect to which a fowl is to be scored, and the perfect score for each feature is 10 points. Provision is made where necessary for scoring features separately in respect to shape and color. The decimal score card differs materially from the official score card, which provides for scoring more features, and these are valued differently for different breeds.

The arguments for or the objections against the decimal system that have arisen have been directed to the fact that no two breeds can be valued the same. Those who favor the decimal system claim that a perfect back in a Plymouth Rock is of equal value to the back of a Partridge Cochins or a Game Bantam, and that neither should have the advantage over the other in the general division of points; that backs for Plymouth Rocks, Cochins, or Bantams can be valued at 10 points as well as to have the back of each fowl estimated at a different percentage. There is evidence of value in the decimal method of calculation from the fact that the monetary system of several countries and the metric system are based on the decimal system. When matters of such vast importance can be conducted best under a decimal system, there should be no hesitation in conceding that the same system will apply equally well in poultry judging. The adoption of the official score card of the American Poultry Association seems to have been based more on the preference of the members of that organization than on a consideration of its relative convenience.

COMPARISON CARD

Variety _____ Judge _____
 Sex and Age _____ At Exhibition held at _____

Date _____

Entry or Coop Number	Symmetry, Shape, or Station	Color of Plumage	Comb, Wattles, and Ear Lobes or Dubbing	Size, Condition Legs and Toes, or Toe-Feathering	Rank or Award	Remarks

FIG. 3

A convenient comparison-judging score card is shown in Fig. 3. Any number of lines needed to complete an entry may be added to this card. The comparison method of judging consists in a careful examination of every section of the fowl, and a determination of the quality by this means, the final placing of awards being decided without numerical estimates. In fact, to judge by comparison is to select the best, by applying, by means of sight estimates, the criteria of perfection established by the Standard.

Comparison judging gives due credit to superior value in individual fowls. No other system gives consideration to unusual quality as equitably as given under the comparison system.

When properly applied, comparison judging can be made more equitable in placing awards than any other system; for selecting the best fowls in the classes, no system is superior to it. The main objection, and, in fact, the only real objection that can be made against it, is that no record is made, nor is there any reason apparent to the absent exhibitor for the award of prizes. A record by scores and the results published conveys a numerical value for individual fowls to the mind of the absentee. In the score card he has comparative numerical values of the fowls that were outside the list of awards.

JUDGING OF FARM FLOCKS AT FAIRS AND SHOWS

M. C. Kilpatrick, Bureau of Animal Industry, Pennsylvania State College, has shown marked interest in having farmers show their poultry at county fairs. He suggests that the flock to be exhibited shall consist of 6 females and 1 male, that each flock be placed in a small coop or runway, where they can be readily viewed, and that the accompanying score card shall be used to judge them.

SCORE CARD FOR FARM FLOCK

GENERAL-PURPOSE TYPE

	PERFECT JUDGE'S	
	SCORE	SCORE
Head: Small, with small combs and wattles; beak, short, stiff, and strong; bright, full eye; face, comb and wattles bright in color and of fine texture	5	—
Neck: Rather short, neat, tapering to head	2	—
Wings: Small and neat	2	—
Back: Of good length, rather broad.....	6	—
Breast: Large, full, rounding, well developed	6	—
Body: Very deep, broad and compact, well fleshed; keel straight and long, well rounded out with flesh; should resemble a parallelogram in shape....	30	—
Skin: Smooth and of fine texture; yellow skin preferred	4	—
Flesh: Firm, evenly distributed; deep, especially in regions of desirable cuts; should give indication of tendency to fatten easily	10	—
Shanks: Short, stiff, and clean.....	3	—
Plumage: Abundant, bright, and well kept; free from dark pin feathers.....	2	—
Disposition: Docile; quiet but active....	2	—
Vitality: Strong; fowls should give evidence of perfect health, freedom from vermin, etc., and must be neat and clean in appearance	10	—
Size: Females shall weigh not less than 5 lb. each, males not less than 7 lb...	8	—
Uniformity: Flock to consist of 6 females and 1 male; females as uniform as possible in type, size, color of plumage, etc.; male, same color as females	10	—
Disqualification: Any evidence of disease, low vitality, scaly leg destroying the natural color of the shank, roach back, crooked toe, or wry tail. Fowls badly infested with lice shall also be disqualified.		

EGG TYPE

PERFECT JUDGE'S
SCORE SCORE

Head: Bright in color, of moderate size, short, broad, and neat; beak, short, stiff, and strong; eye, bright, fully filling the socket, giving an impression of alertness and brightness; comb well developed, medium to large in size, full of blood, and of fine texture	8	_____
Neck: Of medium length, neat and trim	3	_____
Back: Long and reasonably broad.....	8	_____
Body: Compact, broad, and deep, especially in abdomen and fluff, giving plenty of room for vital organs; well rounded out with flesh; plump, yet not fat; good width between pelvic bones, 1½ in. or better, with good distance between rear joint of keel bone and pelvic arch; wings of medium size	20	_____
Breast: Shallower than rear, presenting a wedge shape when viewed from above. Should be rounded, of medium size, giving good lung capacity	8	_____
Shanks and toes: Shanks, stocky, not rangy; of medium length. The fowl should stand up stiff and straight, with body well supported on the tops of the legs, the fowl standing firmly on the toes. Shanks to have full, highly colored skin, loose around the shank; should carry some flesh. Toenails, short and straight.....	5	_____
Tail: Full and flowing, not pinched or stinted; a tendency to be carried high	2	_____
Plumage: Glossy, flowing, abundant, bright, and well kept.....	2	_____
Disposition: Always busy, singing constantly, docile, elusive. The male should be courteous to the hens and exhibit great courage	2	_____
Flesh: Hard, firm, muscular, showing little tendency to lay on fat.....	5	_____
Vitality: Strong, as evidenced by general appearance and condition of the fowl, giving evidence of perfect health, freedom from lice, etc.; must be neat and clean in appearance.....	12	_____

	PERFECT JUDGE'S	
	SCORE	SCORE
Size: Of medium size, female ranging from 3½ to 6 lb.; male, from 4½ to 7 lb.	5	_____
Eggs: Eggs to be of good size, weighing not less than 26 oz. per doz.; must be uniform in shape, size, and color; white eggs to have the preference over brown or tinted eggs, other things being equal; eggs not to be considered unless all flocks are laying during the competition	10	_____
Uniformity: Flock is to consist of 6 females and 1 male; females should be as nearly alike as possible in type, size, plumage, etc.; male should be of same color as females.....	10	_____
Disqualification: Any evidence of disease or low vitality, scaly leg, destroying the natural color of the shank, roach back, or wry tail. Fowls badly infested with lice shall also be disqualified.		

POULTRY SHOWS AND ASSOCIATIONS

BEGINNING OF POULTRY SHOWS

The first poultry exhibition is thought to have been the one held in the Zoological Gardens of London, England, in 1846; the first poultry show held in Birmingham, England, was in 1849. The first poultry exhibition held in America is accredited to Boston in 1849. The first American poultry show to attract world-wide attention was held in the American Museum, New York City, in February, 1854, under the management of P. T. Barnum. The second show was held a year later at the same place. This show was really the beginning of live interest in the breeding of fowls for exhibition in America.

From 1860 to 1865, but little interest was taken in poultry exhibitions in America. From then to the present time they have increased so fast as to surprise the world. During the show season of 1911 and 1912 more than 700 poultry exhibitions were held in the United States and Canada, and more than 200 in England.

The great shows of England are the Dairy, the Birmingham, and the Crystal Palace shows. These three are held usually between Oct. 15 and Nov. 20. The Crystal Palace show of London, England, has for many years been considered the greatest of poultry shows, but within the last few years the New York and Boston shows have come to be considered equal in importance to the Crystal Palace exhibition.

POULTRY-SHOW RULES

Non-members of the American Poultry Association must make application in writing to the secretary, S. T. Campbell, Mansfield, Ohio, for permission to use the copyrighted rules for holding shows, at least 30 da. before the time for printing the premium list. Application for permission to use the rules is considered to be a guarantee that the rules will be strictly observed.

GENERAL RULES

I. Entries

1. Breeders, fanciers, sportsmen, and amateurs are most cordially invited to compete for premiums of this Association.

2. Entries will positively close on [date], but should be sent as long before that date as possible. This rule will be strictly adhered to.

3. The building will be open for the reception of specimens at 8 A. M., Monday, [date], and those not received by 10 A. M., Tuesday [date], will be debarred from competition.

4. The entry fee for poultry in the open class is \$1 per bird; pens, \$2—4 females, 1 male; pet stock, 50c.

5. Birds entered in the open classes cannot compete in the pens.

6. There must be three (3) entries in each and all the classes of poultry or first prize money will be withheld. Where there are less than three entries in a class, second prize money will be paid for first prize winner.

7. Individual season tickets will be issued free of charge to all exhibitors whose entry fee amounts to \$2. Any exhibitor whose entry fee does not amount to \$2 can secure ticket by paying the difference.

8. No specimens will be allowed in the hall except those which have been duly entered in the books of the Association, and the entry fee and express charges paid.

II. *Transportation*

1. Shipping tags will be sent to each exhibitor, which must have the sender's name and address legibly written thereon, and the name of the express company for their return delivery. If from accident the shipping tags do not arrive in time, send exhibits without them, and the secretary will make duplicates.

2. Unhealthy specimens will not be exhibited, but will be returned to the owners at their expense.

3. When more than one specimen is sent in the coop, each entry must be properly divided and separately labeled.

4. All specimens sent will be properly cared for and returned at the close of the exhibition. It will therefore be unnecessary for the owners to accompany them.

III. *Care and Condition*

1. All specimens shall be exhibited in their natural condition, with the exception of games and game bantams. Any violation of this rule shall exclude the specimen from competing and cause the withholding of all premiums awarded the owner of such birds.

2. The association will be pleased to undertake the sale of specimens for the exhibitor, free of charge, selling price to be stated on entry blank. All sales must be reported at the office as soon as made.

3. During the exhibition, no specimens can be removed except by order of the secretary. Any fowl showing disease will be removed and cared for.

4. All signs or advertising matter on coops must be neat and attractive and meet the approval of the secretary.

IV. *Awarding Prizes*

1. The judges shall be selected for their known familiarity with the classes on which they are invited to award premiums.

2. The reports of the judges shall be made in writing, upon blanks provided by the secretary, and will be final, after having been approved by the secretary and board of directors.

3. Immediately after the awards of the judges have been supervised and approved, a card stating the premium will be placed upon each winning coop, where it is to remain until the close of the show.

4. No one will be allowed in the aisles while judging is going on, except the board of directors and the employes of the association.

5. A display shall consist of at least ten entries and will be decided thus: First prize to count 6 points; second, 4; third, 3; fourth, 2; fifth, 1. Pens, points double. In case of a tie, the largest entry will decide.

6. Prizes in cash, special prizes, ribbons, etc., for all exhibits, including pens, will be awarded. Blue ribbon for first prize, red for second, yellow for third, fourth, and fifth. Lost prize ribbons will be duplicated at 15c. each.

MEMBERSHIP IN AMERICAN POULTRY ASSOCIATION

Membership in the American Poultry Association is governed by the following rules taken from the constitution of that organization:

ARTICLE III

Membership

SECTION 1. The members of this association shall consist of five classes, as follows:

(a) *Life*.—Individual membership shall be for life, for which a fee of \$10, payable with the application, shall be charged. The applicant shall be eligible to all rights and privileges of membership immediately following his election by the executive board.

(b) *Associate*.—Any poultry association or society, organized for the purpose of holding annual poultry exhibitions, may become an associate member of this association on payment of a fee of \$10, such membership to be approved by the executive board, and shall be entitled to one representative, having one vote, at meetings of this association. Such associations or societies, on becoming associate members of the American Poultry Association, shall be amenable to its rules and regulations governing poultry associations and shows.

(c) *Clubs*.—Any specialty club, organized in the interest of any breed or variety of standard-bred poultry, may become a member of this association on payment of a fee of \$10, such membership to be approved by the executive board, and shall be entitled to one representative, having one vote, at meetings of this association.

(d) *Society*.—Any society, organized in the interest of poultry culture, may become a member of this association on payment of a fee of \$10, such membership to be approved by the executive board, and shall be entitled to one representative, having one vote, at meetings of this association.

(e) *Branch*.—Any state or province, or any district composed of any combination of adjoining states or provinces, not exceeding six in number, may be organized into one branch association, subject to the constitution and by-laws and the rules and regulations of the American Poultry Association. The membership of branch associations shall be made up of life associate or society members of the American Poultry Association. Each branch association, through its properly accredited representative, who must be a member of the branch association, shall be entitled to one vote at meetings of the American Poultry Association for each five of its members who are not present at roll call.

SEC. 2. All applications for membership of classes (a), (b), (c), and (d) must be made in writing; be addressed to the secretary of the American Poultry Association; bear the indorsement of two members of the association, and receive a majority vote of the executive board, either by mail or in regular or special session. Should the vote on new members be by mail, the secretary shall duly advise all members of the executive board in form and manner required by said board, and in the event that any member of the executive board, within 20 da., objects to an applicant being admitted to membership, such application shall be acted upon by the executive board in regular or special session. No applications shall be approved unless the prescribed membership fee has been paid. Should the applicant fail of approval the fee shall be returned. An application for branch membership must state, over the signature of its secretary, the number of names of its members who are life members of the American Poultry Association.

SEC. 3. The credentials of representatives of branch associations and of associate, club, and society membership, must reach the secretary's hands before the opening roll call of meetings attended by such representatives, otherwise they shall not be entitled to take part in the proceedings as representatives.

SEC. 4. The representative of any club or society must show by his credentials that said club or society has held a regularly called meeting, as provided for by its constitution and by-laws, within 1 yr. from the date of the meeting of this association, in which he seeks to take part, and a certified copy of said constitution and by-laws must have been filed with the secretary of the American Poultry Association at the time of the filing of the application for membership.

SEC. 5. In advance of each annual meeting the secretary shall drop from the roll call all members of the association who are 2 yr. in arrears in the payment of their dues.

SEC. 6. Fifty per cent. of each life, associate, or society membership fee, coming to the secretary of the American Poultry Association through any branch association, for membership in the American Poultry Association, shall, upon the election of the applicant, be returned to the branch from which it came.

REVISION OF THE AMERICAN STANDARD OF PERFECTION

Revision of the American Standard of Perfection is governed by the following extract from the constitution of the American Poultry Association:

ARTICLE X

Revision of Standard

SECTION 1. A general revision of the American Standard of Perfection shall take place once in 5 yr. and not oftener.

SEC. 2. No changes shall be made in any part of the Standard of Perfection unless written notice, specifying word for word the proposed change or changes, shall have been filed with the secretary at least 90 da. before the annual meeting at which the changes are to

be acted upon, in which case the secretary, in announcing the next annual meeting, shall notify all members of the proposed change or changes, specifying the same, word for word. The provision of this section shall not apply to changes made at the meeting at which a general revision shall take place.

SEC. 3. New breeds or varieties shall be admissible to the Standard of Perfection only at the time of general revision. Corrections may be made and omissions supplied by a majority vote at any annual meeting of the association, on recommendation of the standing committee on revision; provided, written notice, specifying word for word the proposed corrections or omissions, shall have been filed with the secretary 90 da. before the date of the annual meeting at which same is to be considered, and that a printed notice specifying such corrections shall have been mailed by him to each member of the association at least 60 da. before the date of said annual meeting.

ADMISSION OF NEW BREEDS AND VARIETIES TO AMERICAN STANDARD OF PERFECTION

New breeds and varieties are admitted to the American Standard of Perfection under the regulations given in the following extract from the constitution of the American Poultry Association:

ARTICLE XI

New Breeds and Varieties

SECTION 1. Before a new breed or variety can be admitted to the American Standard of Perfection it must comply with the following requirements, to-wit:

(a) It must be able to produce 50% of the specimens reasonably true to the type and characteristics of the breed or variety, as set forth in the proposed standard, and must have been exhibited in at least two

generations, both male and female, at not less than one show conducted under American Poultry Association rules in each of three successive annual seasons.

(b) Written statement of one or more poultry judges who are members of the A. P. A. and who officiated at this show, setting forth the qualifications of the specimens for admission to the Standard shall be furnished by said judge to the secretary of the American Poultry Association, who shall forward a copy of the same to the exhibitor of the birds concerned.

(c) If application is made for admission of a new breed, the breed must possess such new breed characteristics as to give it a very distinct character of its own, and if application is made for admission of a new variety, the variety must truly possess all the type characteristics of the breed of which it is a variety. Extraordinary care shall be exercised to prevent multiplicity of varieties.

SEC. 2. A petition addressed to the American Poultry Association shall be presented.

(a) This petition shall contain a description of the breed or variety seeking admission, together with all ascertainable facts regarding its origin and breeding, and a prayer for its admission.

(b) Affidavits of not less than five breeders of the breed or variety shall be presented, containing statements of the percentage of specimens breeding reasonably true to type and characteristics of the breed or variety as above required.

(c) The proposed standard for the breed or variety shall be presented at the same time with the petition, but may be amended by the petitioner or the association before the admission of the breed or variety. This standard shall be read at the meeting at which admission of the breed or variety is sought.

(d) At least ninety (90) days prior to the meeting of the association at which admission to the Standard of Perfection is sought, the papers required in the application shall be filed with the secretary, who shall give to

all members of the association sixty (60) days' notice of the pendency of such application.

SEC. 3. If upon consideration of all the evidence, the association is satisfied that the breed or variety is worthy of recognition in the Standard of Perfection; that it has, in fact, the qualities and characteristics set forth in the application; that all claims and characteristics set forth in the application are justified; and that all requirements for its admission have been complied with, a majority vote of the members present and voting by written ballot shall admit the breed or variety to the Standard of Perfection.

STANDARD AND NON-STANDARD VARIETIES OF POULTRY

Show-room classifications are not the same in all countries or even in all parts of the same country. In America they are usually made to conform to the breeds and their varieties as listed in the American Standard of Perfection. But in addition to such varieties, some show-room classifications will include a few of the non-standard varieties, and the greater number of them will permit classes for any of the non-standard varieties, either of a particular breed or of many breeds.

The list of breeds and varieties of poultry in the accompanying table includes only those that are known to reproduce their kind of a settled type of form and color. In the column headed Standard Varieties are listed the varieties of fowls included in the American Standard of Perfection; in the column headed Non-Standard Varieties are listed the varieties not included in that publication, but which are bred in the United States and other countries, many of them being standard varieties in other countries. In compiling this list, a slight deviation from a set rule has been made. The Antwerp Brahma has been listed under the Asiatic fowls as a non-standard variety. To be strictly correct,

BREEDS AND STANDARD AND NON-STANDARD VARIETIES OF POULTRY

Classes and Breeds	Standard Varieties	Non-Standard Varieties	Color of Eggshell
<i>American fowls:</i> Plymouth Rock.....	Barred Buff Columbian Partridge Silver Penciled White	Black Buff Barred Pea-Comb Rose-Comb	Brown or tinted Brown or tinted Brown or tinted Brown or tinted Brown or tinted
Wyandotte.....	Black Buff Columbian Golden Laced Partridge Silver Laced Silver Penciled White	Buff Columbian Cuckoo Pyle Colored Violet White-Laced Buff	Brown or tinted Brown or tinted Brown or tinted Brown or tinted Brown or tinted Brown or tinted Brown or tinted Brown or tinted
Rhode Island Red.....	Rose-Comb Single-Comb	Pea-Comb White	Brown or tinted Brown or tinted
Dominique.....	Rose-Comb		Brown or tinted
Java.....	Black Mottled		Brown or tinted Brown or tinted
Jersey Blue.....	Pea-Comb	Blue	Brown or tinted
Buckeye.....			Brown or tinted
<i>Asiatic fowls:</i> Brahma.....	Light Dark	Antwerp Buff	Brown or tinted Brown or tinted

Cochin.....	Black Buff Partridge White Black White	Cuckoo	Brown or tinted Brown or tinted Brown or tinted Brown or tinted Brown or tinted
Langshan.....		Blue Buff	
<i>Belgian fowls:</i>		Ermine—White Black-Red	Brown White
Antwerp Brahma.....		Black	White
Ardenne.....		Mottled	White
Brabant.....		Black	White
Brackel.....		Black-Headed Blue	White White
		Chamois	White
		Golden	White
		Silver	White
		White	White
		Black	White
		Golden	White
		Silver	White
		Silver-Gray	White
		Blue	Pale yellow
Bruges.....		Cuckoo	White
Campine.....		Ermine	Tinted
		Golden	Tinted
Flemish.....		Black	Tinted
Herve.....		Cuckoo	Brown or tinted
Huttegem.....			Brown or tinted
Malines.....			

BREDS AND STANDARD AND NON-STANDARD VARIETIES OF POULTRY
(Continued)

Classes and Breeds	Standard Varieties	Non-Standard Varieties	Color of Eggshell
<i>Belgian fowls—(Continued)</i> Malines		Silvered Black Turkey-Headed White	Brown or tinted Brown or tinted Brown or tinted
<i>Dutch fowls:</i> Breda.....		Black Blue Cuckoo White Numerous varieties	White White White White White White White White White White
Drente.....	Black Golden Penciled Golden Spangled Silver Penciled Silver Spangled White		
Hamburg.....			
Owl-Bearded Dutch.....	Rose-Comb	Numerous varieties	White White White Tinted Tinted
Red Cap.....	Colored Silver-Gray White	Cuckoo Rose-Comb Silver-Gray Red Blue Columbian Cuckoo	White White White Tinted Tinted
<i>English fowls:</i> Dorking.....	Single-Comb Black Single-Comb Buff Single-Comb White		
Orpington. /.....			

BREEDS AND STANDARD AND NON-STANDARD VARIETIES OF POULTRY
(Continued)

Classes and Breeds	Standard Varieties	Non-Standard Varieties	Color of Eggshell
<i>Miscellaneous fowls—(Continued):</i>			
Frizzle.....	Red White		Tinted Tinted
Naked Neck.....		Numerous colors	Tinted
Rumpless.....		Numerous colors	Tinted
Silky.....		Numerous varieties	Tinted
Sultan.....	White		Tinted
Yokohama, Tosa, or Phoenix.....		Numerous varieties	Tinted
<i>Bantam fowls:</i>			
Booted.....	White Dark	Black and other varieties	Tinted Tinted
Brahma.....	Light Black		Tinted Tinted
Cochin.....	Buff Partridge White Birchen	Cuckoo	Tinted Tinted
Exhibition Game Bantam	Black Black-Breasted Red	Old-English Wheaten	White or slightly tinted White or slightly tinted Slightly tinted

Brown-Red	White or slightly tinted
Golden Duckwing	White or slightly tinted
Red Pyle	White or slightly tinted
Silver Duckwing	White or slightly tinted
White	White or slightly tinted
Black	White or slightly tinted
Black-Tailed	White or slightly tinted
White	White or slightly tinted
Bearded White	White or slightly tinted
Buff Laced	White or slightly tinted
Non-Bearded	White or slightly tinted
Black	White or slightly tinted
White	White or slightly tinted
Golden	White or slightly tinted
Silver	White or slightly tinted
Japanese.....	Buff
Polish.....	Duckwing
Rose-Comb.....	Splashed
Sebright.....	White-Crested Black
	Golden
	Silver

BREDS AND STANDARD AND NON-STANDARD VARIETIES OF POULTRY

(Continued)

Classes and Breeds	Standard Varieties	Non-Standard Varieties	Color of Eggshell
<i>Miscellaneous bantams:</i>			
Andalusian.....		Blue	White or slightly tinted
Aseel.....		Black-Red	Tinted
Frizzle.....		Numerous varieties	Tinted
German.....		Numerous varieties	Tinted
Langshan.....		Black	Tinted
Leghorn.....		Numerous varieties	Tinted
Malay.....	Black-Red	Numerous varieties	Tinted
Minorca.....		Black	Tinted
Nankin.....		Buff	Tinted
Rumpless.....		Numerous colors	Tinted
Scotch Gray.....		Cuckoo	Tinted
Silky.....	White		Tinted
Spanish.....		Black	Tinted
Sultan.....		White	Tinted
Yokohama.....		Numerous varieties	Tinted
<i>Ducks:</i>			
Aylesbury.....	White		White or tinted with green
Call.....	Gray		Tinted
	White		Tinted
Cayuga.....	Black		Green
Crested.....	White		Tinted
East India.....	Black		Green

Huttegem.....	Fawn-White	Broken colors, Blue-white	Tinted
Indian Runner.....	Colored	White	White
Khaki.....	White	Buff (female is penciled)	Tinted
Muscovy.....	White		White
Orpington.....	White	Buff	Tinted
Partridge.....	Colored	Partridge colored	Tinted
Pekin.....	Blue		White
Rouen.....	Gray		Greenish tint
Swedish.....	Brown		Blue tinted
<i>Geese:</i>	White		
African.....	Colored	Buff colored	White
Buff.....	White		White
Chinese.....	White		White
Egyptian.....	Colored		Tinted
Embsden.....	White		White
Toulouse.....	Gray		White
Wild, or Canadian.....	Gray, marked with black		Tinted
<i>Guinea fowls:</i>			
		Gray	Speckled
		Pearl	Speckled
		Vulturine	Speckled
		White	Speckled
		Black-Winged	Speckled
		Common	Speckled
		Javan	Speckled
		White	Speckled
<i>Peafowls:</i>			

BREEDS AND STANDARD AND NON-STANDARD VARIETIES OF POULTRY
(Continued)

Classes and Breeds	Standard Varieties	Non-Standard Varieties	Color of Eggshell
<i>Turkeys:</i>	Black Bourbon Red Bronze Buff Narragansett Slate White	Cambridge Bronze Ronquieres Fawn Gray .	Speckled Speckled Speckled Speckled Speckled Speckled Speckled

NOTE.—Bantam fowls of the same breed are apt to lay either white or tinted eggs. Ducks of the same breed may lay either white or tinted eggs; some have a greenish and others a bluish tint. The eggs of geese may be white, grayish white, or cream colored.

this variety is not a true Brahma of the accepted type, but a Belgian variety, and for the sake of convenience and uniformity it is listed as both an Asiatic and a Belgian fowl. In this table the name used for each variety is the name commonly applied to it in its native country.

AMERICAN POULTRY SPECIALTY CLUBS

Following is a list of the American Poultry Specialty Clubs, with the name and address of the secretary for each for 1912. The latest address of the secretary of any club may be obtained from S. T. Campbell, Secretary of the American Poultry Association, Mansfield, Ohio.

American Black Minorca Club, Frank McGrann, Secy., Lancaster, Pa.

American Bourbon Red Turkey Club., E. J. Reed, Secy., Oblong, Ill.

American Buff Leghorn Club, Geo. S. Barnes, Secy., Marshall, Mich.

American Buff Plymouth Rock Club, William A. Stolts, Secy., R. F. D. No. 19, Indianapolis, Ind.

American Buff Wyandotte Club, Henry R. Ingalls, Secy., Greenville, N. Y.

American Buttercup Club, I. F. Tillinghast, Secy., Factoryville, Pa.

American Campine Club, M. R. Jacobus, Secy., Ridgefield, N. J.

American Columbian Plymouth Rock Club, Edw. B. Kaple, M. D., Secy., Elbridge, N. Y.

American Cornish Club, F. H. Williams, Secy., Minneapolis, Minn.

American Dominique Club, A. Q. Carter, Secy., Freeport, Me.

American Dorking Club, Robt. Officer, Secy., N. Grafton, Mass.

American Exhibition Game and Game Bantam Club, C. F. Schenker, Secy., 141 E. 25th St., New York, N. Y.

202 *POULTRY SHOWS AND ASSOCIATIONS*

American Langshan Club, Rees F. Matson, Secy., Greencastle, Ind.

The American Houdan Club, John T. Heizer, Pres., Columbus, O.

American Leghorn Club, W. W. Babcock, Secy., Bath, N. Y.

American Orpington Club, Frank W. Gaylor, Secy., Mt. Vernon, N. Y.

American Partridge Plymouth Rock Club, S. A. Noftzger, Secy., North Manchester, Ind.

American Barred Plymouth Rock Club, A. C. Smith, Secy., Waltham, Mass.

American White Wyandotte Club, Geo. W. Dakin, Secy., Roxbury, Mass.

American White Orpington Club, F. S. Dullington, Secy., Box 328, Richmond, Va.

The Ancona Club of America, Geo. Johnson, Secy., 377 So. Detroit Ave., Toledo, O.

Blue Andalusian Club, E. L. C. Morse, Secy., 7411 Bond Ave., Chicago. Ill.

Buff Minorca Club of America, S. O. Lindgren, Pres., Kingsburg, Cal.

Canadian Barred Plymouth Rock Club, F. R. Boyce, Secy., London, Ont.

Canadian Leghorn Club, Wm. Cadman, Secy., St. Thomas, Ont.

Canadian White Plymouth Club, P. Dill, Secy., Seaforth, Ont.

Canadian White Wyandotte Club, J. F. Daly, Secy., Seaforth, Ont.

Columbian Wyandotte Breeders' Association of America, Philip Koehlinger, Secy., Ft. Wayne, Ind.

Hamburg Fanciers' Club, W. L. Allen, Secy., 62 Franklin St., Boston, Mass.

International Ancona Club, J. W. McNary, Secy., Bannock, O.

International Bantam Breeders' Club, Mrs. A. J. Kimmey, Morgan Park, Ill.

International Waterfowl Association, Theo. F. Jager, Secy., Pittsford, N. Y.

International Rose-Comb Black Minorca Club, Lloyd C. Mishler, Secy., North Manchester, Ind.

National Bronze Turkey Club, E. F. Pullins, Secy., Rensselaer, Ind.

National Columbian Wyandotte Club, Geo. F. Eastman, Secy., Granby, Mass.

National Exhibition Game and Game Bantam Club, E. J. Dietz, Secy., Downer's Grove, Ill.

National Partridge Wyandotte Club, William Erfurth, Secy., South Chicago, Ill.

National Red Feather Club, Edgar L. Andrews, Secy., Ithaca, N. Y.

National Rose-Comb Rhode Island Red Club, W. F. Burleigh, Secy., Larrabee's Point, Vt.

National Rose-Comb White Leghorn Club, Lincoln, Ill.

National Single-Comb Rhode Island Red Club, Cedar Rapids, Ia.

National Single-Comb White Leghorn Bantam Club, C. H. Yates, Secy., Greenville, S. C.

National Single-Comb Buff Orpington Club, V. O. Hobbs, Secy., Trenton, Mo.

National Single-Comb White Leghorn Club, F. O. Groesbeck, Secy., Hartford, Conn.

National White Wyandotte Club, L. J. Demberger, Secy., Stewartsville, Ind.

National White Indian Runner Duck Club, J. H. Reynolds, Secy., Box 300, Atlanta, Ga.

New England White Wyandotte Club, Arthur G. Duston, Secy., South Framingham, Mass.

Partridge Wyandotte Club, H. R. Hildreth, Secy., Worcester, Mass.

Plymouth Rock Club of Southern California, H. D. Armstrong, Secy., 603 W. 41st Drive, Los Angeles, Cal.

Rhode Island White Club, Mrs. C. M. Vertrees, Secy., Cecelian, Ky.

Rhode Island Red Club of America, W. H. Card, Secy., Manchester, Conn.

Silver Penciled Wyandotte Club, G. S. Boiler, Secy., Little Valley, N. Y.

Silver Wyandotte Club, Henry Steinmesch, Secy., 220 Market St., St. Louis, Mo.

Waterfowl Club of America, Mrs. W. P. Mastern, Secy., Pleasant Valley, N. Y.

Western Black Minorca Club, O. H. Wilson, Secy., 1268 So. Logan Ave., Denver, Colo.

White Plymouth Rock Club, Charles H. Ward, Secy., Bethel, Conn.

STANDARD WEIGHTS OF POULTRY

The accompanying table gives the standard weights of all poultry having standard weights, the average weight of those standard fowls that do not have standard weights, and the average weights of non-standard poultry. At the end of the table is a list of notes giving, among other things, the disqualifying weights of bantam fowls.

The weights given for non-standard fowls and for fowls that do not have standard weights have been gathered, so far as possible, from records printed in countries where the fowls have originated and where they are best known and most plentifully bred. Fowls of all breeds that are intended to be of a medium size or larger average heavier in weight in England than in America. The Mediterranean, the American, the English, and the French fowls average heavier in England than in America. The English prefer general-purpose fowls and select to have them as heavy as possible consistent with the dual purpose of table poultry and egg production. In America, the Mediterranean fowls have been kept within the weights considered best suited for fowls bred for egg production. The American breeds have been controlled within the proportions considered best suited for general-purpose breeds.

STANDARD WEIGHTS OF POULTRY

FOWLS

Classes and Breeds	Cock Pounds	Hen Pounds	Cockerel Pounds	Pullet Pounds
<i>American fowls:</i>				
Plymouth Rock.	9½	7½	8	6
Wyandotte.....	8½	6½	7½	5½
Rhode Island				
Red.....	8½	6½	7½	5
Dominique.....	7	5	6	4
Java.....	9½	7½	8	6½
*Jersey Blue.....	10	8	7	5
Buckeye.....	9	6	8	5
<i>Asiatic fowls:</i>				
Light Brahma ..	12	9½	10	8
Dark Brahma ..	11	8½	9	7
Cochin.....	11	9½	9	7
Langshan.....	9½	7½	8	6½
<i>Belgian fowls:</i>				
*Antwerp Brahma	12	9½	10	8
*Ardenne.....	15 to 6½	24 to 5		
*Brabant.....	8	6	7	5
*Braekel.....	16 to 8	24 to 6		
*Bruges.....	18 to 10	27 to 9		
*Campine.....	14½ to 5	23½ to 4		
*Flemish.....	16½ to 9	24½ to 6		
*Herve.....	13 to 4	22 to 3		
*Huttegem.....	19 to 11	27 to 9		
*Malines.....	19 to 11½	28 to 10	10	8
<i>Dutch fowls:</i>				
*Breda.....	16 to 9	25 to 6½		
*Drente.....	15 to 5½	24 to 4½		
*Hamburg.....	5	4		
*Owl-Bearded				
Dutch.....	7½	5½	6½	4½
Red Cap.....	7½	6	6	5
<i>English fowls:</i>				
*Colored Dorking	9	7	8	6
Silver-Gray				
Dorking.....	8	6½	7	5½
White Dorking .	7½	6	6½	5
Orpington.....	10	8	8½	7
*Scotch Dumpy..	18	25 to 6		
*Scotch Gray....	19 to 11	27 to 9		

TABLE—(Continued)

Classes and Breeds	Cock Pounds	Hen Pounds	Cockerel Pounds	Pullet Pounds
<i>English fowls—</i> (Continued):				
*Sussex.....	10½ to 11½	8½ to 9½	9 to 10	7 to 8
<i>French fowls:</i>				
Crevecoeur.....	8	7	7	6
7Houdan.....	7½	6½	6½	5½
La Flèche.....	8½	7½	7½	6½
*La Bresse.....	15 to 6½	24½ to 5½		
*Bourbourg.....	16¾ to 9	26 to 7		
*Faverolle.....	7 to 8½	6 to 7	6 to 7	5 to 6
<i>Game fowls:</i>				
3Exhibition Game	17 to 9	25 to 7		
Cornish, or In-				
dian, Game...	9	7	8	6
White-Laced				
Red Cornish..	8	6	7	5
*Malay.....	9	7	7	5
*Sumatra.....	15 to 6	24 to 5		
*Aseel.....	16	25		
*Old-English....	14½ to 7	24 to 5		
<i>German fowls:</i>				
Lakenfelder....	15 to 6	23½ to 4½		
<i>Mediterranean</i>				
<i>fowls:</i>				
*Ancona.....	16	25		
Andalusian....	6	5	5	4
*Leghorn.....	15½ to 7	24½ to 5½		
Single-Comb Mi-				
norca.....	9	7½	7½	6½
Single-Comb				
White and				
Rose-Comb				
Black Minorca	8	6½	6½	5½
Spanish.....	8	6½	6½	5½
*Polish fowls:....	15½ to 6½	21 to 5		
<i>Miscellaneous fowls:</i>				
*Frizzle.....	9½	7½	8	6
*Naked Neck....	9½	7½	8	6
*Rumpless.....	7	5	6	4
*Silky.....	6	4	5	3
*Sultan.....	15	24		
*Yokohama, Tosa,				
or Phoenix....	14½ to 6	22½ to 4		

TABLE—(Continued)
BANTAM FOWLS

Classes and Breeds	Cock Ounces	Hen Ounces	Cockerel Ounces	Pullet Ounces
<i>Standard bantam fowls:</i>				
*Booted.....	26	22	22	20
*Brahma.....	30	26	26	24
*Cochin.....	30	26	26	24
<i>Exhibition Game Bantam.....</i>				
	22	20	20	18
*Japanese.....	26	22	22	20
*Polish.....	26	22	22	20
*Rose-Comb....	26	22	22	20
*Sebright.....	26	22	22	20
<i>Miscellaneous bantams:</i>				
*Andalusian....	26	22	22	20
*Aseel.....	26	24	24	22
*Frizzle.....	30	26	26	24
*German.....	30	26	26	24
*Langshan.....	30	26	26	24
*Leghorn.....	26	22	22	20
*Malay.....	26	24	24	22
*Minorca.....	30	26	26	24
*Nankin.....	30	26	26	24
*Rumpless.....	30	26	26	24
*Scotch Gray...	30	26	26	24
*Silky.....	30	26	26	24
*Spanish.....	26	22	22	20
*Sultan.....	30	26	26	24
*Yokohama.....	30	26	26	24

DUCKS

Classes and Breeds	Adult Drake Pounds	Adult Duck Pounds	Young Drake Pounds	Young Duck Pounds
Aylesbury.....	9	8	8	7
*Call.....	12½ to 3	*2 to 2½		
Cayuga.....	8	7	7	6
Crested.....	7	6	6	5
East India.....	7	6	6	5
*Huttegem.....	7	6	6	5
Indian Runner...	4½	4	4	*3½

TABLE—(Continued)

Classes and Breeds	Adult Drake Pounds	Adult Duck Pounds	Young Drake Pounds	Young Duck Pounds
*Khaki.....	7	6	6	5
Muscovy.....	10	7	8	6
*Orpington.....	7	6	6	5
*Partridge.....	7	6	6	5
Pekin.....	9	8	8	7
Rouen.....	9	8	8	7
Swedish.....	8	7	6½	5½

GEESE

Classes and Breeds	Adult Gander Pounds	Adult Goose Pounds	Young Gander Pounds	Young Goose Pounds
African.....	20	18	16	14
*Buff.....				
Chinese.....	12	10	10	8
Egyptian.....	10	8	8	6
Embden.....	20	18	18	16
Toulouse.....	25	20	20	16
Wild, or Canadian	12	10	10	8

TURKEYS, GUINEA FOWLS, AND PEAFOWLS

Classes and Breeds	Cock Pounds	Hen Pounds	Cockerel Pounds	Pullet Pounds
<i>Turkeys:</i>				
Black.....	27	18	18	12
Bourbon Red...	30	18	22	14
Bronze.....	1736	20	25	16
Buff.....	27	18	18	12
*Cambridge				
Bronze.....	118 to 24	112 to 16		
*Fawn.....	118 to 20	112 to 16		
*Gray.....	28	16	18	10
Narragansett...	1830	18	20	12
*Ronquieres.....	30	18	20	12
Slate.....	27	18	18	12
White.....	28	18	20	14
<i>Guinea fowls:</i>				
All varieties....	14 to 6	13 to 5		
<i>Peafowls:</i>				
All varieties....	112 to 18	17 to 12		

NOTES ON STANDARD WEIGHTS OF POULTRY

- *Non-standard breed.
- ¹Cock and cockerel.
- ²Hen and pullet.
- ³No standard weights.
- ⁴At 10 mo.
- ⁵Penciled Hamburgs. In other Hamburg varieties the fowls are somewhat heavier.
- ⁶Colored Dorking cocks often weigh from 12 to 14 lb.; hens and cockerels, from 9 to 10 lb.; and pullets, from 7 to 8 lb.
- ⁷It is not unusual for Houdans to exceed these weights.
- ⁸Standard height, cock, 26 in.; hen, 18 in.; cockerel, 18 in.; pullet, 15 in.
- ⁹Disqualifying weights for Booted Bantams: cocks, 28 oz.; hens, 24 oz.; cockerels, 24 oz.; pullets, 22 oz.
- ¹⁰Disqualifying weights for Brahma Bantams: cocks, 34 oz.; hens, 30 oz.; cockerels, 30 oz.; pullets, 28 oz.
- ¹¹Disqualifying weights for Cochin Bantams: cocks, 34 oz.; hens, 30 oz.; cockerels, 30 oz.; pullets, 28 oz.
- ¹²Disqualifying weights for Black-Tailed Japanese Bantams: cocks, 30 oz.; hens, 26 oz.; cockerels, 26 oz.; pullets, 24 oz.
Disqualifying weights for White Japanese Bantams: cocks, 30 oz.; hens, 26 oz.; cockerels, 26 oz.; pullets, 24 oz.
Disqualifying weights for Black Japanese Bantams: cocks, 30 oz.; hens, 26 oz.; cockerels, 26 oz.; pullets, 24 oz.
- ¹³Disqualifying weights for Polish Bantams: cocks, 30 oz.; hens, 26 oz.; cockerels, 26 oz.; pullets, 24 oz.
- ¹⁴Disqualifying weights for Rose-Comb Bantams: cocks, 28 oz.; hens, 24 oz.; cockerels, 24 oz.; pullets, 22 oz.
- ¹⁵Disqualifying weights for Sebright Bantams: cocks, 30 oz.; hens, 26 oz.; cockerels, 26 oz.; pullets, 24 oz.
- ¹⁶English standard weights for Malay Bantams: cocks, 3½ lb.; cockerels and hens, 3 lb.; pullets, 2 lb.
- ¹⁷Weight of adult Bronze turkey cock; yearling cock weighs 33 lb.
- ¹⁸Weight of adult Narragansett turkey cock; yearling cock weighs 25 lb.

MARKING OF POULTRY FOR IDENTIFICATION

MARKING OF FOWLS

To attain the greatest success in breeding poultry, whether for egg production, market purposes, or fancy stock, a poultryman must know the pedigree of the fowls mated, and in order to be able to identify each fowl, some system of marking chicks must be adopted.

A system of toe markings that can be used for a limited number of fowls is shown in Fig. 1. As shown in the illustration, fifteen different combinations can be made by punching holes in the toes of chicks. A number of forms of punches are made for this purpose; several of these are shown in Fig. 2 (a), (b), (c), (d), and (e). Care must be exercised to entirely remove the severed portion of the web to prevent it from growing together again. The wound will heal in a few days.



In building up a strain of good layers, the beginning is usually made by marking chicks from the most prolific layers. The same principle is applied in the establishment of a good strain of market poultry. These markings are used on the progeny of selected stock only and serve as a guide for the selection of the pullets that should be saved for winter layers. Those that have toe markings should be kept, no matter what their appearance may be, for in this way only can a good start be made.

FIG. 1 Records can be kept quite as readily with chicks artificially hatched as with hen-hatched chicks. The partitioned incubator egg tray can be used for holding the eggs from selected hens. The eggs are marked

with numbers before they are placed in the incubator for hatching. On the eighteenth day of incubation, the numbered eggs are transferred from the regular egg tray into the special tray. When hatched in this tray, the chicks cannot get out of it. After they have been marked, the chicks may be placed in a brooder with other chicks with no danger of their identity becoming lost. Separated trays can be used in any incubator. Partitions can be made of tin or wood, and they can be placed in the egg trays to separate the eggs as well as the chicks when they are hatched. When they are used, the unmarked chicks must not be allowed to drop into the nursery; if this is permitted, their identity will be lost.

To keep a correct record of chicks hatched by hens, each hen should have eggs from only one hen given her for hatching.

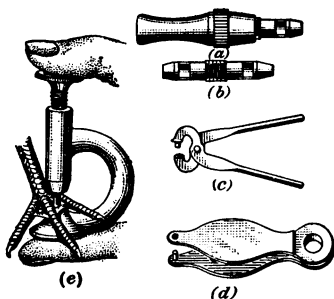

FIG. 2

The toe-marking system is satisfactory for a small number of selected fowls, but when the breeding operations are on an extensive scale some other system of marking must be adopted. Bands of some kind for attaching to the shanks, as shown in Fig. 3, are satisfactory for marking fowls and permit of sufficient

variations. Several forms of aluminum bands are shown in Fig. 4. The small band shown in (a) is suitable

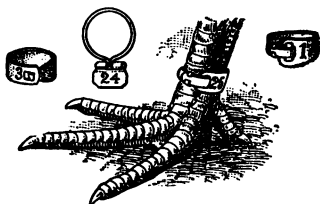

FIG. 3

for placing around the shank of a chick, and later, when the shank grows too large for this band, it may be removed and fastened through the web of the wing. The band shown in (b) is used for chicks also, but is

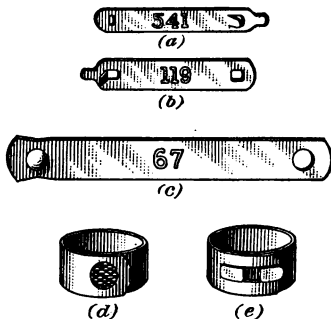

FIG. 4

rather too wide to insert in the web of the wing. After a fowl reaches its full growth, a band like that shown in

(c), which may be sealed, may be fastened about the shank. This band, fastened with a rivet, is shown in (d). The fastening is done very easily with a pair of pincers, as shown in Fig. 5. After being well fastened



FIG. 5

or sealed, such a band will last the lifetime of a fowl, unless removed by cutting. All of these bands may be stamped with any number or other characters desired. A type of aluminum band known as an interlocking band is shown in Fig. 4 (e).

Colored celluloid bands are used for marking fowls kept in large flocks. They are most useful when used in connection with the metal bands and serve as a means of quick identification for various large groups

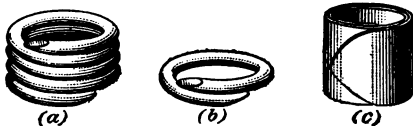

FIG. 6

of fowls when they are kept in big flocks; that is, all the chicks hatched in one year may have a blue band; those hatched the next year, a red band; the next, a yellow band; and so on. In this way the age of fowls

may be told at a glance. The bands may be used also to identify strains or families of fowls. Though they have their usefulness in this way, they are not an absolutely accurate means of identifying fowls; in addition they are liable to be lost from the shank; in such cases, if no other band were used, the identity of a fowl would be lost. Three celluloid markers are shown in Fig. 6. The ring shown in (a) encircles the shank a number of times. One end of this is hooked about the shank and then the rest is wound around much in the same manner that a key is worked on a key ring. The ring shown in (b) is a small one of the same type as that shown in (a). In (c) is shown a flat celluloid band. Poultry supply houses sell celluloid rings and bands in as many as eight different colors.

MARKING OF PIGEONS

To build up the productiveness of a flock of pigeons and to maintain the quality of the squabs, it is necessary to mark breeding pigeons in such a way that their identity can be easily determined. This is usually done by fastening a suitably marked band of some kind about the shank of each bird. A careful record of each breeding pigeon should be kept in a record book. This record should include the ancestors of each bird, their egg production, the time it takes for them to hatch their squabs, the time it takes for them to rear their squabs to a marketable size, and notes as to the quality of their squabs. With this information systematically arranged it will be possible to prevent harmful inbreeding and to mate the offspring of different pigeons in such a way as to improve the productiveness and quality of the flock.

Bands suitable for marking breeding pigeons can be obtained in several styles from dealers in poultry supplies. Some of these bands are made so that they indicate only the year in which the breeders were first mated. This is usually done in one of two ways, either by having

different-colored bands for each year, samples of which are shown in Fig. 7, or by stamping the year on the band,

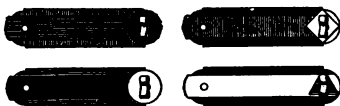

FIG. 7

as shown in Fig. 8. The colored bands are usually more easily distinguished at a little distance than those stamped with figures. Other shank bands, in addition to indicating the year in which the breeders were first mated, have a numeral or some other mark that indicates



FIG. 8

the ancestors of the birds. Such bands, however, are used principally in the breeding of exhibition pigeons, the system being too complicated for the producer of commercial squabs.

In marking breeding pigeons, it is customary to place the band on the right shank of male birds and on the left shank of female birds. Squabs that are to be kept for breeders should have a band placed on them as soon as they are ready to leave the nest. At this time it is impossible to determine the sex, but the band can be placed on either shank to preserve the identity of the squabs, and can be shifted, if necessary,



FIG. 9

when the sex can be determined. Two shank bands attached to birds are shown in Fig. 9; the one shown in (a) is attached to the right shank of a male pigeon, and that shown in (b) is attached to the left shank of a female pigeon.

In Fig. 10 is shown a device for holding pigeons while bands are being placed on their shanks. Such a device



FIG. 10

is particularly useful when the band must be placed on the bird by one person. In using this device the pigeon is pushed gently, head down, into the cone, where it is held without injury. The band is then fastened about the shank and the pigeon released from the cone.

CALENDAR FOR THE POULTRY- MAN'S YEAR

OCTOBER

October is usually the beginning of the poultryman's year. Ring out the old and ring in the new is usually practiced at this time. All of the old fowls that are useless should be marketed; the flock should be separated and the old hens and young pullets placed in different apartments.

As the weather grows colder, more precaution must be taken to prevent ailment from creeping into the flock. All specimens, old or young, which lack size, strength, or vitality should be culled out from the flock; nothing but strong, healthy specimens should remain.

The poultry buildings should be of such a character that no drafts of air can blow through them. All air and ventilation should come in from the front of the building.

NOVEMBER

The spring-hatched pullets should be laying at this time, and the best of egg-producing rations should be fed to them and to the old hens as well.

The growing green food having disappeared, a plentiful supply of sprouted oats, alfalfa hay, and other green foods should be provided to take its place. The floor of the poultry house should be well covered with dry litter and the green food should be thrown on it. This will encourage the fowls to work for all the food they get, and in this way they will be made active and more healthy. Fowls that are too weak to work for a living are usually poor layers and might as well be sold to market.

An additional culling of the flock should be made at this time. No male over 2 yr. old should be kept. The earliest and best cockerels of the year are best for breeding purposes.

No hen or pullet that does not show the proper indication for egg production should be kept after this period.

November and December are the early winter months during which time all hens and pullets should begin to lay. If they have been carefully fed they will do so.

Hens and pullets should have a good egg-producing diet at this time. One of the necessities of poultry during winter months is that they shall be protected from the elements, have plenty of exercise of some kind, and be fed on a liberal grain ration composed of the grains best suited to egg production. A liberal supply of green food, also, should be fed during the winter months.

DECEMBER

This month is the most severe on poultry and the most trying on poultrymen of all months of the year. The houses should be kept warm and dry and free from drafts; all cracks and openings should be carefully covered or stopped up to prevent drafts through the houses.

Hens will lay but few eggs at this time, when the price is high and the eggs most desirable. For this reason every effort possible should be made to make the hens lay. The only way to secure a good supply of eggs for market at this time is to have a thorough knowledge of the possibilities of egg production through scientific management and feeding. No one not fully informed on these matters can hope to have a full egg supply from hens or pullets during midwinter months.

Plenty of green food, well-selected grains, the proper quantity of nourishing food, and fresh water are necessities at this time.

JANUARY

Poultry work requires constant attention during this month.

Cull out the less perfect fowls and sell all those not intended for producing market eggs or for breeding.

During the last part of January look over the fowls and become acquainted with those suitable for breeding, so that no time will be lost when the season for mating arrives.

Fowls will need more fattening food, such as corn and barley. A good plan to follow during the winter is to feed a grain ration composed half of corn and the other half of equal parts of wheat, oats, and barley.

Twice a week or every other day feed green cut bone.

Dry mash is one of the most popular kinds of food for poultry during the winter months. One-third of a winter dry-mash mixture should consist of corn meal and the rest of wheat bran and wheat middlings and some ground oats. The same ration should be fed during Jan., Feb., and March, especially in parts of the world where these months are cold and stormy.

Supply fowls with plenty of green foods, such as turnips, rutabagas, cabbage, lettuce, cut clover, hay, cut alfalfa, etc.

FEBRUARY

Winter is coming to a close, and spring-like diseases will prevail in some localities. Farthest north, cold weather will continue for some time.

Houses should be protected from spring rains, snow and sleet; either glass windows or curtain fronts make good protection.

It is now time to mate fowls for the production of eggs for hatching; select the best of all and keep them separate for special breeding. No sick fowls nor fowls that have deformities or that lack superior quality should ever be used in the breeding pen. The best of all the fowls on any farm will produce many culls; this is reason enough for using only the selected specimens for breeding.

A liberal supply of green food is always beneficial at this time, because such food increases the density of the albumen of an egg, and the heavier or more dense the albumen of the egg the greater strength it will have for nourishing a chick in the embryo state.

MARCH

March is the most uncertain month of the year. Weather conditions cannot be depended on. March winds are the most piercing of the year, and the fowls must be protected from the elements.

Little chicks should be kept under hovers that are inside of a building that is tight enough to protect them from the elements. March chicks make Nov. layers.

Incubators should now be in action. Nests made for sitting hens should be deep so as to provide a comfortable nest for the hen. Always dust the body of a sitting hen with insect powder. Persian insect powder is the best. Dust it down well into the feathers and close to the skin of the fowl. This dusting should be renewed every 3 or 4 da. for 1 wk. or 10 da.

A soap box 18 in. or 2 ft. square with some sand or earth in the bottom and dry hay or straw packed well down on top of this, provides an excellent nest for a sitting hen.

The nest for a sitting hen should always be placed where she will have plenty of room, light, and shelter from the elements, yet be confined where she cannot run away from the eggs. She should be watched and put back on the eggs if she seems to neglect them.

APRIL

April is usually the most favorable month of the year for hatching chicks; at this time the grass and all vegetables are sending up new growth, and there is plenty of natural food for the little chicks.

April is the month when all incubators should be filled with eggs for hatching, and all broody hens should have a clutch of eggs.

See to it that the brooding hens are well fed while doing their family duty. Laying hens should have more green food at this time than before. Corn bread is good food for the mother hen and little chicks. To make such corn bread mix 1 teaspoonful of baking powder into a mixture composed of 1 pt. of corn meal, $\frac{1}{2}$ pt. of wheat bran, 4 oz. of good meat scrap, and a little

bone meal, and add a pinch of salt. Stir the mass up, moistening it well with milk or water, milk preferred, and bake in the oven. When well baked and cool, it can be crumbled and fed to the little chicks.

April, May, and June are the spring months in northern latitudes. Less fattening grain should be fed during this period; some wheat and less corn should be fed to the poultry, and they should have an increased supply of green food; if bugs and worms are not plentiful on the range, they should have animal food of some kind.

Young chicks and growing stock should be fed liberally during this period; they cannot have too much wholesome grain. Some dry mash is helpful; if it is desirable to grow them quickly for market purposes, wet mash may be used.

MAY

Both old fowls and young chicks should have greater freedom during the month of May than during the preceding months.

All parts of the poultry houses, the nest boxes, and

the runways should be thoroughly cleaned. Brush the ground thoroughly with a stiff broom; after the top cover has been swept away, dig up the soil and turn it under.

Chicks of the Asiatic, American, and English breeds should be hatched prior to the middle of May; those of the Mediterranean breeds should be hatched before the end of May. Chicks of all kinds will do well if hatched after June 1, but they are seldom of much value to the poultryman except for table purposes.



INDIAN RUNNER DRAKE

JUNE

In some localities the weather will be very warm during the month of June. Shade is an important consideration at this time, and where it does not exist naturally it must be supplied artificially.

During this month less fattening foods than given in preceding months will answer, and less corn and more wheat and oats should be fed. Dry mash that contains but little corn meal should be used.

The warmer the weather the more green food and pure fresh water will be needed for the fowls. No fat meat, but some lean meat should be fed to the laying hens during this month.

June is apt to be the last month of the year in which chicks are hatched and the eggs from which they are hatched should be strong and full of vitality to infuse abundant health and vigor into the chicks. If the fowls can have free range through the fields and woods at this time it will be of benefit to them.

JULY

Cool, shady places and freedom from the irritation of overheated houses and insect vermin should be the order of the day.

Poultry must have shade at this time to protect them from the glaring rays of the sun, which will scorch and blister their backs and make life a burden to them.

On the farms, all the male fowls should be taken away at this time and sold. They are of no further use after the hatching season is over.

Thousands of eggs shipped to market during the heated term are destroyed because the eggs begin to hatch. This will occur in the egg boxes traveling on trains when the temperature is above 100° F. If no males are kept with the hens, especially on farms in the southern climates, there will be fewer spoiled eggs in transit.

If all the hens can be turned into a wood or on land from which grain has been harvested it will be beneficial to them.

Plenty of fresh, cool water for drinking and a clean place for roosting must be provided during the heated term.

Insect vermin, including lice and mites, will throng the poultry in the poultry houses during the heated term, unless prevented through cleanliness and care.

July and August are the hardest months of the year in the latitude where heat is intense during that period. During the hot period fowls should have principally wheat and oats—ground oats, wheat bran, and wheat middlings as a dry mash.

Fowls intended for market during fall months should be fed liberally during this period with fattening food and be sold to market as soon as they are well fattened.

Shade is an absolute necessity during the heated period. If natural shade does not exist artificial shade of some kind must be provided.

Fowls should be in full molt at this time. Hens that are overly fat do not molt quickly; hens that are very thin in flesh are slow to molt. Fowls in good condition usually molt the best; those that are too fat should have less to eat; those that are thin in flesh should be fed liberally; those that molt well should be protected from cold drafts and have a good, nourishing ration. Fowls that have free range will need only proper grain diet.

AUGUST

During the heated term of dog days, old and young fowls of all kinds, including turkeys and water fowls, suffer intensely from heat, and plenty of green food, grit, and fresh water should be provided.

At this time all old fowls, male and female, past 2 yr. old should be sold. The hens would lay but few eggs from now until winter, and as market poultry they will probably bring more than at any other time for the next 3 mo.

Continued cleanliness in and about the poultry houses, freedom from insect vermin, and free reign are the necessities at this time.

SEPTEMBER

September is the turning point in the life of both young and old fowls. The old fowls are in molt and the young fowls finish their coat of feathers at this time, and they must be well cared for and fed. They must be built up for the coming winter, and for this reason should have more nourishing, more strengthening, and more fattening foods than they have had during the summer.

Cold rains, changeable weather, and cool winds may be injurious to poultry at this time. Colds, catarrh, and

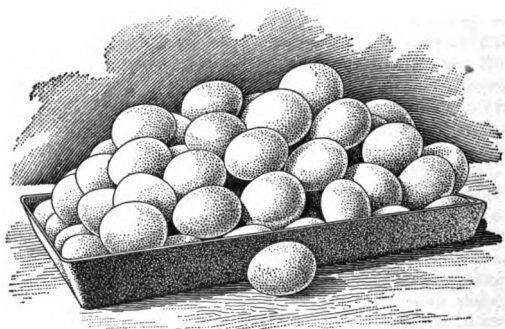

INDIAN RUNNER DUCK EGGS

roup may injure the fowls. A change from outdoor life or from closed coops into unclean poultry buildings may do great injury to them.

All of the buildings should be swept out perfectly clean, and all cracks and crevices should be brushed and freed absolutely from dust, dirt, and lurking vermin. The floors, doors, and windows should be put in good repair and the inside of the buildings sprayed with some material that is both healthy and a perfect insect destroyer and disinfectant. Plenty of green food

and an increased quantity of animal food should be fed at this time.

September is the beginning of the fall, and at this time hens lay but little. Early-hatched pullets should begin to lay; these should have special care and feeding. All poultry should be fed at this time with reference to the winter egg production.

MISCELLANEOUS INFORMATION

How to Ascertain the Age of Fowls.—It is difficult for an amateur to decide the age of fowls. Experienced poultrymen are at times unable to decide from outward appearance. But few rules are safe to follow; some of them, however, may be depended on.

The surface of the skin under the wing of a pullet will be interspersed or marked with rose-colored veins; these are totally absent in hens that are more than 12 mo. old. The skin of pullets will be fairly well covered with long, silky hair; this disappears directly after the first molt.

In an adult hen the skin will be white and free from either veins or hairs. If these are absent it can be seen at a glance that the fowl, if a hen, must be more than 1 yr. old.

The points of the pelvic bones grow much closer together in a pullet than in a hen, yet this cannot always be depended on, as the cause of the spreading of the pelvic bone is prolific egg production. Hens that never lay may have the points of the pelvic bones close together, even though very old. Usually, however, this test can be depended on.

The scales and skin on the shanks and feet of young fowls are usually smooth and tender, and the toenails are longer and more pointed than the toenails of older fowls. The scales and skin on the shanks and feet of older fowls become rough and turn a whitish gray with age. Scaly legs and roughness of any kind on the

shanks and feet indicate an age of more than a year, in all kinds of poultry, including turkeys, ducks, and geese.

The faces of poultry more than 1 yr. old lose their smooth finished appearance and become wrinkled and drawn. The eyes and eyelids of fowls more than 1 yr. old do not have the fresh appearance of young poultry.

One of the best indications of the age of fowls is the appearance of the secondaries. At the conclusion of the first complete molt, which occurs when the fowl is about 12 mo. old, the secondaries alter in shape and



FIG. 1

show evidence of the dividing line between the young and the old fowl. This change of the secondaries cannot be readily described. The wings of pullets and of old hens must be held alongside of one another and compared and studied in order to appreciate the marked change that occurs in the shape or form of these feathers.

Proper Way to Hold a Fowl.—When a fowl is carried about or held in the hands it should be held in a position that is comfortable for it and cleanly for the person holding it. When a fowl is held by the shanks and feet with the head hanging down, it suffers considerable pain, and if the crop contains water, the water will

run out through the gullet and partly strangle the bird.

One of the most cleanly ways to carry a fowl is shown in Fig. 1. The thighs are held in the hand with one finger in between them to avoid too much pressure on the bones, and the breast of the fowl rests on the forearm of the person holding it. The fowl suffers no inconvenience, and there is little danger of the clothing of the holder being soiled by voidings from the bird.

When the fowl is held as shown in Fig. 2, the feet of the fowl are free to rub against the clothing of the holder, and any filth from it will be liable to drop on



FIG. 2

and smear the clothing of the person holding the bird.

The rule to observe in carrying a fowl is to carry it with the head toward and the tail away from the holder.

Proper Way to Hold a Squab.—Great care should be exercised in picking up squabs, as it is very easy to injure them. Squabs should be picked up by gently passing the fingers of the right hand under the crop and breast, placing the left hand on the back, and sliding the bird into the palm of the right hand without gripping it with the fingers. Care should be taken to see that the crop of the bird is not injured. When the

crop of a squab is full it is heavy and apt to be injured if held tightly. It is not necessary to close the fingers



FIG. 3

about. The proper way in which a squab should be held is shown in Fig. 3. In Fig. 4 is shown a squab being held by the fingers. This is the improper way to hold squabs under ordinary circumstances, because there is a tendency to squeeze them too tightly, but it is sometimes necessary to hold very lively squabs in this manner.

Proper Way of Catching and Holding Pigeons.—Catching and holding pigeons should be done with care, or

the birds may be injured. Pigeons should never be roughly handled or held by the feet or by the wings alone. The proper method of holding a pigeon is shown in Fig. 5. As shown, the hand is placed around the rear portion of the

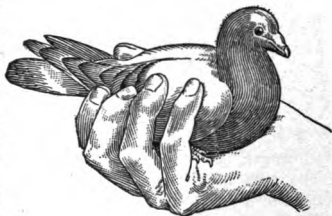

FIG. 4

body, the wings and tail are held gently but firmly by the hand, and the shanks are held between two fingers to prevent them from moving. When pigeons are held in this way they will be comfortable and will not struggle to free themselves, hence the wing and tail feathers of the birds will not become broken, and females will not be

injured during their egg-laying period. If female pigeons are chased in a pigeon house and roughly grabbed with the hands or caught in a dip net, they are very likely to be injured, especially if this is done during their egg-laying period. In pigeon houses that are so built that the birds are able to roost high overhead, no attempt should be made to catch them except at night, and then a box or a step ladder should always be used to stand on.

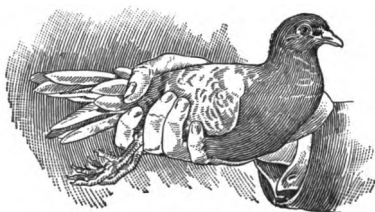

FIG. 5

Legal Weights per Bushel of Various Commodities. Following are given the legal weights per bushel of various commodities for which bushel weights have been adopted in but one or two states and legal weights per bushel for commodities for which legal weights have been widely adopted.

Alsike (or Swedish) seed, 60 lb. (Md. and Okla.).

Beggar weed seed, 62 lb. (Fla.).

Bermuda grass seed, 40 lb. (Okla.).

Blackberries, 30 lb. (Ia.); 48 lb. (Tenn.); dried, 28 lb. (Tenn.).

Blueberries, 42 lb. (Minn.).

Bromus inermis, 14 lb. (N. Dak.).

Bur clover, in hulls, 8 lb. (N. C.).

Cabbage, 50 lb. (Tenn.).

Canary seed, 60 lb. (Tenn.); 50 lb. (Ia.).

Cantaloup melon, 50 lb. (Tenn.).

Castor seed, 50 lb. (Md.).

NOTES RELATING TO PRECEDING TABLE

- ¹Not defined.
²Small white beans, 60 lb.
³Green apples. [wurzels.
⁴Sugar beets and mangel
⁵Shelled beans, 60 lb.; velvet beans, 78 lb.
⁶White beans.
⁷Wheat bran.
⁸Green unshelled beans, 56 lb.
⁹English blue-grass seed, 22 lb.; native blue-grass seed, 14 lb.
¹⁰Also castor seed.
¹¹Soybeans, 58 lb. [30 lb.
¹²Green unshelled beans,
¹³Soybeans.
¹⁴Free from hulls.
¹⁵Commercially dry, for all hard woods.
¹⁶Fifteen lb. commercially dry, for all soft woods.
¹⁷Standard weight in borough of Greensburg.
¹⁸Dried beans.
¹⁹Red and white.
²⁰Corn in ear, 70 lb. until Dec. 1 next after grown; 68 lb. thereafter.
²¹Sweet corn.
²²On the cob.
²³Indian corn in ear.
²⁴Unwashed plastering hair, 8 lb.; washed plastering hair, 4 lb.
²⁵Corn in ear, from Nov. 1 to May 1 following, 70 lb.; 68 lb. from May 1 to Nov. 1.
²⁶Indian-corn meal.
²⁷Cracked corn.
²⁸Shelled.
²⁹Free from hulls.
³⁰Standard weight bu. corn meal, bolted or unbolted, 48 lb.
³¹Except the seed of long staple cotton, of which the weight shall be 42 lb.
³²Green unshelled corn, 100 lb.
³³Green cucumbers.
³⁴See also "Pop corn," "Indian corn," and "Kafir corn."
³⁵Green peaches.
³⁶Green pears.
³⁷Malt rye.
³⁸Top sets; bottom sets, 32 lb.
³⁹Shelled, 56 lb.
⁴⁰Shelled, dry.
⁴¹Strike measure.
⁴²Bottom onion sets.
⁴³German and American.
⁴⁴Shelled.
⁴⁵Peaches (peeled); unpeeled, 32 lb.
⁴⁶Cowpeas.
⁴⁷Roasted; green, 22 lb.
⁴⁸Not stated whether peeled or unpeeled.
⁴⁹Top onion sets.
⁵⁰Including split peas.
⁵¹In the ear.
⁵²Slaked lime, 40 lb.
⁵³German, Missouri, and Tennessee millet seeds.
⁵⁴Matured onions.
⁵⁵Bottom onion sets, 32 lb.
⁵⁶Matured.
⁵⁷Matured pears, 56 lb.; dried pears, 26 lb.
⁵⁸Black-eyed peas.
⁵⁹Barley malt.
⁶⁰Includes Rice corn.
⁶¹Rice corn.
⁶²Sorghum saccharatum seed.
⁶³Red top grass seed (chaff); fancy, 32 lb.
⁶⁴Seed.
⁶⁵Irish potatoes.
⁶⁶Free from hulls.
⁶⁷Ground salt, 70 lb.
⁶⁸India wheat, 46 lb.
⁶⁹In some states herd's grass is a synonym for timothy; in other states for red top.

The states of Idaho, New Mexico, Utah, and Wyoming have no standard for bushel weights.

- Cement, 80 lb. (Tenn.).
Cherries, 40 lb. (Ia.); with stems, 56 lb. (Tenn.); without stems, 64 lb. (Tenn.).
Chufa, 54 lb. (Fla.).
Cotton seed, staple, 42 lb. (S. C.).
Culm, 80 lb. (Md.).
Currants, 40 lb. (Ia. and Minn.).
Feed, 50 lb. (Mass.).
Fescue, seed of all the, except the Tall and Meadow fescue, 14 lb. (N. C.).
Fescue, Tall and Meadow fescue grass seed, 24 lb. (N. C.).
Grapes, 40 lb. (Ia.); with stems, 48 lb. (Tenn.); without stems, 60 lb. (Tenn.).
Guavas, 54 lb. (Fla.).
Hominy, 60 lb. (Ohio); 62 lb. (Tenn.).
Horseradish, 50 lb. (Tenn.).
Italian rye-grass seed, 20 lb. (Tenn.).
Japan clover in hulls, 25 lb. (N. C.).
Johnson grass, 28 lb. (Ark.); 25 lb. (N. C.).
Kale, 30 lb. (Tenn.).
Land plaster, 100 lb. (Tenn.).
Lentils, 60 lb. (N. C.).
Lucerne, 60 lb. (N. C.).
Lupines, 60 lb. (N. C.).
Meadow seed, tall, 14 lb. (N. C.).
Meal (?), 46 lb. (Ala.); unbolted, 48 lb. (Ala.).
Middlings, fine, 40 lb. (Ind.); coarse middlings, 30 lb. (Ind.).
Millet, Japanese barnyard, 35 lb. (Mass. and N. H.).
Mustard, 30 lb. (Tenn.).
Mustard seed, 58 lb. (N. C.).
Oat grass seed, 14 lb. (N. C.).
Plums, 40 lb. (Fla.); 64 lb. (Tenn.); dried, 28 lb. (Mich.).
Prunes, dried, 28 lb. (Idaho); green, 45 lb. (Idaho).
Radish seed, 50 lb. (Ia.).
Raspberries, 32 lb. (Ia. and Kan.); 48 lb. (Tenn.).
Rhubarb, 50 lb. (Tenn.).

- Sage, 4 lb. (Tenn.).
Salads, 30 lb. (Tenn.).
Sand, 130 lb. (Ia.).
Seed of brome grasses, 14 lb. (N. C.).
Spinach, 30 lb. (Tenn.).
Strawberries, 32 lb. (Ia.); 48 lb. (Tenn.).
Sugar cane seed (amber), 57 lb. (N. J.).
Sunflower seed, 24 lb. (N. C.).
Teosinte, 59 lb. (N. C.).
Velvet grass seed, 7 lb. (Tenn.).
Vetches, 60 lb. (N. C.).

POULTRY STATISTICS

VALUE OF POULTRY AND POULTRY PRODUCTS

According to the returns of the census of 1910, the value of the poultry on farms of the United States on Apr. 15, 1910, was \$154,663,220, the value of the poultry produced on farms in 1909 was \$202,506,272, and the value of the eggs produced in the same year was \$306,688,960, a total value of \$663,858,452 for poultry and poultry products for the year. These figures do not represent the value of all the poultry and poultry products of the country, for the reason that the census covers only the farms, no returns being made of the poultry and eggs produced in cities, towns, and villages, and about 12% of the farms failed to make returns. It has been estimated from this that the total value of the poultry and poultry products of the United States for the year 1909 was not far from \$750,000,000.

The total value of the poultry and poultry products of the United States for the year ending June 30, 1912, has been estimated by the United States Department of Agriculture and the commission houses of the country to be approximately \$950,000,000.

POULTRY ON FARMS IN THE UNITED STATES

The following table from the 1910 census gives the numbers of the various kinds of poultry reported in 1910 and 1900 as being on farms in the United States on the dates the censuses were taken, and also the value of the various kinds of poultry and the number of farms reporting each kind in 1910.

Number of Farms Reporting Poultry.—The total number of farms reporting poultry in 1910 was 5,585,032, or 87.8% of all farms in continental United States. Only 6,507 of the farms reporting poultry failed to report chickens. Turkeys were reported from 871,123 farms, or 13.7%; ducks from 503,704, or 7.9%; geese from 662,324, or 10.4%; guinea fowls from 339,538, or 5.3%; and pigeons from 109,407, or 1.7%.

Number and Value of Fowls.—The number of fowls reported in 1910 was 295,880,000, and their total value was \$154,663,000, or an average value of 52c. Nearly 95% of all the fowls were chickens; they numbered 280,345,000, and their value was \$140,206,000, the average value being 50c. Turkeys numbered 3,689,000 and were valued at \$6,606,000, the average value being \$1.79. The ducks reported numbered 2,907,000, and were valued at \$1,567,000, with an average value of 54c. Of geese the total number was 4,432,000, and the value \$3,195,000, or an average value of 72c. In 1910 there were also reported 1,765,000 guinea fowls, valued at \$613,000; 2,731,000 pigeons, valued at \$762,000; and 6,458 peafowls, valued at \$18,300. Ostriches to the number of 5,361 were reported, with a value of \$1,696,000, or over \$300 each. The ostriches were reported from five states: Arizona, Arkansas, California, Florida, and Texas.

Changes in Number and Value of Fowls, 1900 to 1910. The total number of fowls in the United States increased from 250,624,000 in 1900 to 295,880,000 in 1910, a gain of over 45,000,000, or 18.1%. The figures for the two censuses are comparable, despite the change in date of enumeration, fowls under 3 mo. old being excluded

POULTRY STATISTICS

POULTRY ON FARMS IN THE UNITED STATES

Kind	1910 (Apr. 15)			1900 (June 1)		Per Cent. Increase in Number, 1900 to 1910 ¹
	Farms Reporting		Number of Fowls	Value	Average Value	
	Number	Per Cent. of all Farms				
Total.....	5,585,032	87.8	295,880,190	\$154,663,220	\$.52	18.1
Chickens.....	5,578,525	87.7	280,345,133	\$140,205,607	\$.50	20.0
Turkeys.....	871,123	13.7	3,688,708	6,605,818	1.79	-44.1
Ducks.....	503,704	7.9	2,906,525	1,567,164	.54	-39.3
Geese.....	662,324	10.4	4,431,980	3,194,507	.72	-21.9
Guinea fowls.....	339,538	5.3	1,765,031	613,282	.35	
Pigeons.....	109,407	1.7	2,730,994	762,374	.28	
Peafowls.....	1,807	(⁴)	6,458	18,328	2.84	
Ostriches.....	29	(⁴)	5,361	1,696,140	316.38	683.8

¹ A minus sign (-) denotes decrease.² Included with chickens.³ Not reported⁴ Less than one-tenth of 1 per cent.

in both cases. The number of turkeys, ducks, and geese, however, decreased very materially in nearly every section of the country. The aggregate increase in fowls was, therefore, due to the increase in the number of chickens, which rose from 233,566,000 to 280,345,000, or 20%. The percentage of decrease for turkeys was 44.1, for ducks, 39.3, and for geese 21.9. Comparable figures for the minor classes of fowls—guinea fowls, peafowls, and pigeons—are not available for 1900. The number of ostriches reported in 1900 was only 684, or about one-eighth as many as in 1910.

The percentage of increase in value of poultry was over four times as great as that in number, amounting to 80.2%. The average value per fowl thus rose from 34c. in 1900 to 52c. in 1910.

NUMBER AND VALUE OF ALL FOWLS ON FARMS IN THE UNITED STATES

The following table from the 1910 census shows for continental United States, for the nine geographic divisions of the country, and for each state, the number and value of all fowls on farms in the United States in 1910 and 1900 and the per cent. of increase in value for the decade.

Every geographic division reports an increase during the decade in number of fowls on farms. The greatest actual additions appeared in the East North Central and West North Central divisions, and these two divisions also had a greater percentage of increase than any of the others except the rapidly growing Mountain and Pacific divisions. For the two North Central divisions combined the number of fowls increased 22.7%; for the Mountain and Pacific divisions combined, 55.9%; for the East and West South Central divisions combined, 4.3%; for the New England division, 7.2%; for the Middle Atlantic division, 15.7%; and for the South Atlantic division, 13.8%.

The number of chickens increased during the decade in every one of the geographic divisions, but the number

NUMBER AND VALUE OF ALL FOWLS ON FARMS IN THE UNITED STATES

Division or State	All Fowls ¹				Per Cent. of Increase
	Number		Value		
	1910	1900	1910	1900	
United States.....	295,880,190	250,624,038	\$154,663,220	\$85,807,818	80.2
<i>Geographic Divisions:</i>					
New England.....	7,078,636	6,060,246	\$5,238,461	\$3,611,668	45.0
Middle Atlantic.....	26,004,625	22,473,907	17,775,385	10,095,094	76.1
East North Central.....	71,941,382	61,558,039	39,070,998	20,819,906	87.7
West North Central.....	88,684,488	69,298,838	44,226,368	22,596,723	95.7
South Atlantic.....	27,858,263	24,472,713	13,631,507	8,545,899	59.5
East South Central.....	26,918,569	25,851,926	11,873,198	8,063,673	47.2
West South Central.....	31,501,899	30,170,335	11,910,631	7,612,990	56.5
Mountain.....	6,708,606	3,265,650	4,656,963	1,362,014	241.9
Pacific.....	10,183,722	6,926,384	6,279,709	3,099,851	102.6
<i>New England:</i>					
Maine.....	1,735,962	1,585,564	\$1,131,921	\$756,153	49.7
New Hampshire.....	924,859	877,939	649,121	467,104	39.0
Vermont.....	938,524	843,163	607,787	421,195	44.3
Massachusetts.....	1,798,380	1,690,693	1,492,961	1,018,119	46.6
Rhode Island.....	415,209	520,514	368,018	305,047	20.6
Connecticut.....	1,266,702	1,098,373	988,653	644,050	53.5

Middle Atlantic:						
New York.....	10,678,836	9,352,412	7,879,388	4,310,755	82.8	
New Jersey.....	2,597,448	2,076,514	2,221,610	1,300,853	70.8	
Pennsylvania.....	12,728,341	11,044,981	7,674,387	4,483,486	71.2	
East North Central:						
Ohio.....	17,342,289	15,018,352	9,532,672	5,085,921	87.4	
Indiana.....	13,789,109	11,949,821	7,762,015	4,222,409	83.8	
Illinois.....	21,409,835	17,737,262	11,696,650	6,415,033	82.3	
Michigan.....	9,967,039	8,405,060	5,610,958	2,685,829	108.9	
Wisconsin.....	9,433,110	8,447,544	4,468,703	2,410,714	85.4	
West North Central:						
Minnesota.....	10,697,075	8,142,693	4,646,960	2,274,649	104.3	
Iowa.....	23,482,880	20,043,343	12,269,881	6,535,464	87.7	
Missouri.....	20,897,208	16,076,713	11,870,972	5,720,359	107.5	
North Dakota.....	3,268,109	1,489,380	1,485,463	477,358	211.2	
South Dakota.....	5,251,348	3,178,285	2,356,465	856,966	175.0	
Nebraska.....	9,351,830	7,812,239	4,219,158	2,374,930	77.7	
Kansas.....	15,736,038	12,556,185	7,377,469	4,356,997	69.3	
South Atlantic:						
Delaware.....	876,081	665,282	560,146	357,475	56.7	
Maryland.....	2,908,958	2,305,645	1,858,570	1,158,020	60.5	
District of Columbia.....	8,349	8,293	6,477	3,108	108.4	
Virginia.....	6,099,581	5,041,470	3,395,962	1,886,768	80.0	
West Virginia.....	3,310,155	3,053,071	1,628,700	963,805	69.0	
North Carolina.....	5,053,870	4,379,961	2,212,570	1,434,158	54.3	
South Carolina.....	2,946,414	2,908,319	1,206,615	889,953	35.6	
Georgia.....	5,328,584	4,926,452	2,088,653	1,458,055	43.3	
Florida.....	1,326,271	1,184,220	673,814	394,557	70.8	
East South Central:						
Kentucky.....	8,764,204	7,855,468	4,461,871	2,723,221	63.8	
Tennessee.....	8,056,145	6,971,737	3,757,337	2,275,864	65.1	

NUMBER AND VALUE OF ALL FOWLS ON FARMS IN THE UNITED STATES
(Continued)

Division or State	All Fowls ¹				Per Cent. of Increase
	Number		Value		
	1910	1900	1910	1900	
<i>East South Central—(Continued):</i>					
Alabama.....	5,028,104	5,186,536	\$1,807,239	\$1,409,269	28.2
Mississippi.....	5,070,116	5,838,185	1,846,751	1,655,319	11.6
<i>West South Central:</i>					
Arkansas.....	5,788,570	6,092,876	2,063,432	1,540,006	34.0
Louisiana.....	3,542,447	4,299,479	1,326,614	1,057,889	25.4
Oklahoma.....	8,501,237	4,916,598	3,713,943	1,416,127	162.3
Texas.....	13,669,645	14,861,382	4,806,642	3,598,968	33.6
<i>Mountain:</i>					
Montana.....	966,690	556,679	628,436	296,806	111.7
Idaho.....	1,053,876	540,009	598,190	203,127	194.5
Wyoming.....	341,050	149,564	194,078	60,397	221.3
Colorado.....	1,721,445	1,017,120	1,012,251	393,219	157.4
New Mexico.....	531,625	163,015	256,466	62,419	310.9
Arizona.....	268,762	174,972	1,545,966	103,298	1,396.7
Utah.....	691,941	556,753	327,908	186,922	75.4
Nevada.....	133,217	107,538	93,668	55,826	67.8
<i>Pacific:</i>					
Washington.....	2,272,775	1,356,715	1,367,440	614,838	122.4
Oregon.....	1,823,680	1,373,203	1,067,743	582,524	83.3
California.....	6,087,267	4,196,466	3,844,526	1,902,489	102.1

¹ Includes number and value of pigeons, peafowls, and ostriches in 1910, and number and value of ostriches in 1900. Pigeons and peafowls not enumerated prior to 1910. * Includes Indian Territory.

of turkeys, ducks, and geese decreased in every division, except that there were increases of turkeys and geese in the Mountain division and a slight increase in ducks in the Middle Atlantic division.

Ten Leading Poultry States.—Of the ten states leading in total value of poultry on farms, Iowa has the largest total value of poultry, amounting to \$12,269,881, and Missouri ranks second, with \$11,870,972. The eight states next in order are Illinois, \$11,696,650; Ohio, \$9,532,672; New York, \$7,879,388; Indiana, \$7,762,015; Pennsylvania, \$7,674,387; Kansas, \$7,377,469; Michigan, \$5,610,958; and Texas, \$4,807,642. In these ten states together the value of poultry is about \$86,482,000, or 55.9% of the total value of poultry in continental United States.

DISTRIBUTION OF FOWLS IN THE UNITED STATES

The accompanying table from the 1910 census shows the per cent. distribution of all fowls in the United States in 1910 and 1900. It will be seen that the greater number of fowls is raised in the East North Central and the West North Central divisions of the United States, for of the total number of fowls in continental United States in 1910, considerably over one-half, or 54.3%, were in the two North Central divisions. About one-fifth, or 19.8%, were in the two South Central divisions; somewhat over one-tenth, or 11.2%, in the New England and Middle Atlantic divisions; somewhat less than one-tenth, or 9.4%, in the South Atlantic division; and 5.4% in the two Western divisions—the Mountain and Pacific.

The distribution of chickens among the several geographic divisions naturally corresponds very closely to the distribution of the total number of fowls, since chickens constitute much the greater proportion of all fowls. In the case of the other classes of fowls, the two North Central divisions have a somewhat smaller proportion of the total for the country than in the case

POULTRY STATISTICS

PER CENT. DISTRIBUTION OF TOTAL NUMBER OF FOWLS IN THE UNITED STATES

Division or Section	Per Cent. of Total Number in United States											
	All Fowls		Chickens and Guinea Fowls		Turkeys		Ducks		Geese			
	1910	1900	1910	1900	1910	1900	1910	1900	1910	1900	1900	
United States.....	100.0	100.0	100.0	100.0	100.0	100.0	100.0	100.0	100.0	100.0	100.0	100.0
New England.....	2.4	2.6	2.4	2.8	.7	.7	1.8	1.9	.6	.5	2.1	2.1
Middle Atlantic.....	8.8	9.0	8.7	9.2	6.8	7.3	12.7	7.6	1.9	1.9	16.4	16.4
East North Central.....	24.3	24.6	24.7	24.9	19.0	22.8	18.8	21.3	14.4	14.4	17.0	17.0
West North Central.....	30.0	27.6	30.3	28.0	22.6	23.8	27.9	29.2	21.7	21.7	16.0	16.0
South Atlantic.....	9.4	9.8	9.2	9.5	14.3	12.3	11.4	9.6	15.3	15.3	27.0	27.0
East South Central.....	9.1	10.3	8.8	9.8	13.1	12.0	11.9	11.7	25.9	25.9	18.6	18.6
West South Central.....	10.6	12.0	10.5	11.7	16.8	16.4	12.0	14.6	18.6	18.6	3.3	3.3
Mountain.....	1.9	1.3	1.9	1.3	2.4	1.2	1.5	1.1	.6	.6	2.1	2.1
Pacific.....	3.4	2.8	3.4	2.8	4.3	3.4	2.2	3.1	1.0	1.0	36.0	36.0
The North.....	65.5	63.8	66.1	64.8	49.1	54.6	61.1	60.0	38.6	38.6	61.6	61.6
The South.....	29.2	32.1	28.5	31.1	44.2	40.8	35.2	35.9	59.8	59.8	2.4	2.4
The West.....	5.4	4.1	5.4	4.1	6.7	4.6	3.7	4.2	1.6	1.6	62.0	62.0
East of the Mississippi.....	54.0	56.2	53.9	56.2	53.9	55.1	56.5	52.0	58.1	58.1	38.0	38.0
West of the Mississippi.....	46.0	43.8	46.1	43.8	46.1	44.9	43.5	48.0	41.9	41.9		

AVERAGE VALUE PER FOWL OF ALL FOWLS IN THE UNITED STATES

Division	Average Value of all Fowls		Average Value, 1910							
	1910	1900	Chickens	Turkeys	Ducks	Geese	Guinea Fowls	Pigeons	Peafowls	Ostriches
	United States.....	\$0.52	\$0.34	\$0.50	\$1.79	\$0.54	\$0.72	\$0.35	\$0.28	\$2.84
New England.....	.74	.55	.73	3.08	.98	2.12	.68	.56	9.83	
Middle Atlantic.....	.68	.45	.67	2.49	.80	1.65	.49	.41	4.56	
East North Central.....	.54	.34	.53	1.90	.59	1.03	.33	.22	2.34	
West North Central.....	.50	.33	.48	1.88	.51	.90	.34	.16	2.69	
South Atlantic.....	.49	.35	.46	1.72	.46	.59	.35	.33	2.30	427.17
East South Central.....	.44	.31	.42	1.64	.38	.48	.30	.22	2.15	393.08
West South Central.....	.38	.25	.36	1.24	.37	.52	.29	.16	2.81	338.88
Mountain.....	.82	.42	.55	2.11	.77	1.69	.63	.27	5.35	211.96
Pacific.....	.62	.45	.57	2.24	.74	1.30	.72	.29	4.87	

of chickens; of turkeys, 41.6% were reported from these two divisions; of ducks, 46.6%; and of geese, only 36.1%. The two South Central divisions combined had 44.5% of the total number of geese, a very much larger percentage than in the case of chickens.

AVERAGE VALUE PER FOWL OF ALL FOWLS IN THE UNITED STATES

The preceding table from the 1910 census shows the average value of fowls on farms in the United States. In the case of chickens, turkeys, and ducks, the average values in 1910 were lowest in the West and South Central divisions, and the highest in New England. New England also shows the highest average value for geese, and the lowest is in the East South Central division. The average value of fowls of all classes combined shows a marked increase from 1900 to 1910 in every geographical division of the United States.

PRODUCTION OF POULTRY AND EGGS IN THE UNITED STATES

PRODUCTION ON FARMS ACCORDING TO CENSUS

As given by the 1910 census, the production of poultry and eggs on farms in the United States in 1909 is shown in the accompanying table. Special attention is called to the fact that the statistics in this table include only the poultry and eggs produced on farms in 1909, the value of poultry at any particular date not being considered; and special attention is also called to the fact that the production on farms only was taken, as no enumeration was provided by law for cities, towns, or villages.

Increase in Value of Poultry and Eggs.—The total number of farms reporting fowls raised in 1909 was 5,655,754, or 88.9% of all farms in the United States; and the number of such fowls was 488,468,354, or an average

of 86.4 fowls per farm. No report was published in 1900 showing the number of farms reporting or the number of fowls raised in 1899, but the total value was given as \$136,830,152, as against a value in 1909 of \$202,506,272. It will thus be seen that the value of poultry produced in 1 yr. shows an increase during the decade of over \$65,500,000, or 48.0%.

The last census shows that in 1909 there were produced in the United States 1,591,311,371 doz. eggs, valued at \$306,688,960. The production in 1899 was 1,293,662,433 doz. eggs, and the value was \$144,240,541. While the production of eggs during the 10 yr. increased but 23.0%, the value more than doubled, the exact amount of gain being \$162,448,419, or 112.6%.

Production of Poultry and Eggs by Divisions.—Of the nine main geographic divisions into which the census divides the country, the East and West North Central divisions combined reported over 46.3% of all poultry, and 52.7% of the eggs produced in 1909. The latter division ranks first, with a total of 123,853,667 fowls raised, having a value of \$52,337,180. The eggs produced in this division amounted to 446,336,192 doz., valued at \$77,493,327. The average value per fowl was 42c., and the average value per dozen of eggs was 17c.

The East North Central division raised 102,496,192 fowls in 1909, valued at \$47,972,887. The average value per fowl was 47c. During the same year 392,304,118 doz. eggs were produced, with a total value of \$75,237,900, or an average value per dozen of 19c.

The three Southern divisions, comprising the South Atlantic, the East, and the West South Central, together reported over 39% of all poultry raised in 1909. Of these the South Atlantic produced the greatest number, 70,792,154, having a total value of \$24,413,963, or an average of 35c. per fowl. In the same year there were produced in this division 136,073,767 doz. eggs, with a total value of \$26,545,679, or an average of 20c. per doz.

The West South Central division is fifth in rank in the production of poultry and third in that of eggs, but

FOWLS AND EGGS PRODUCED ON FARMS IN THE UNITED STATES IN 1909

Division or State	Fowls Raised			Eggs Produced		
	Farms Reporting	Number	Value	Farms Reporting	Dozens	Value
United States.....	5,655,754	488,468,354	\$202,506,272	5,634,780	1,591,311,371	\$306,688,960
<i>Geographic Divisions:</i>						
New England.....	158,807	11,139,439	\$7,361,038	157,498	55,078,175	\$15,155,991
Middle Atlantic.....	434,672	36,313,031	21,527,077	433,672	161,921,598	37,507,52
E. North Central....	1,055,125	102,496,192	47,972,887	1,052,789	392,304,118	75,237,900
W. North Central....	1,015,619	123,853,667	52,337,180	1,013,815	446,336,192	77,493,327
South Atlantic.....	985,833	70,792,154	24,413,963	978,590	136,073,767	26,545,679
E. South Central....	907,570	61,199,837	19,128,878	904,856	129,133,681	22,283,364
W. South Central....	817,435	59,066,127	17,681,375	814,587	165,557,865	26,395,765
Mountain.....	129,988	8,799,190	4,373,143	129,052	35,504,102	8,582,548
Pacific.....	150,705	14,808,717	7,710,731	149,921	69,401,873	17,486,834
<i>New England:</i>						
Maine.....	49,641	2,601,733	1,454,815	49,165	14,935,959	3,792,335
New Hampshire....	22,158	1,394,654	879,014	21,951	7,499,470	2,043,338
Vermont.....	28,157	1,282,524	759,362	28,041	7,037,082	1,715,221
Massachusetts.....	30,458	3,212,339	2,411,078	30,151	14,145,240	4,280,445
Rhode Island.....	4,652	602,335	482,015	4,603	2,894,081	848,527
Connecticut.....	23,741	2,045,854	1,374,754	23,587	8,566,343	2,476,125
<i>Middle Atlantic:</i>						
New York.....	196,664	13,980,792	8,403,162	196,290	72,349,034	17,101,732
New Jersey.....	30,652	4,847,288	3,846,029	30,463	14,842,859	3,903,005
Pennsylvania.....	207,356	17,484,951	9,277,886	206,919	74,729,705	16,502,815

<i>East North Central:</i>									
Ohio.....	255,797	23,433,005	10,997,633	255,347	100,889,599	19,748,658			
Indiana.....	203,862	23,067,814	10,726,137	203,576	80,755,437	15,287,205			
Illinois.....	238,768	32,352,888	15,404,028	237,928	100,119,418	18,940,454			
Michigan.....	191,583	12,877,537	6,191,440	191,174	59,915,851	11,734,799			
Wisconsin.....	165,115	10,764,948	4,653,649	164,764	50,623,813	9,526,784			
<i>West North Central:</i>									
Minnesota.....	143,722	11,862,787	4,714,919	143,460	53,807,974	9,767,410			
Iowa.....	206,638	29,990,147	13,914,985	206,389	109,760,487	19,235,600			
Missouri.....	261,189	31,913,210	14,572,585	260,812	111,816,693	19,345,602			
North Dakota.....	62,022	4,043,481	1,530,402	61,808	17,294,322	3,045,687			
South Dakota.....	62,145	6,186,427	2,355,567	62,034	25,067,489	4,244,291			
Nebraska.....	116,515	15,274,150	5,866,508	116,249	46,929,923	7,990,377			
Kansas.....	163,388	24,583,465	9,382,214	163,063	81,659,304	13,864,360			
<i>South Atlantic:</i>									
Delaware.....	10,181	1,562,370	838,533	10,142	4,448,482	968,970			
Maryland.....	46,462	5,949,459	3,011,382	46,346	15,533,732	3,235,759			
Dist. of Col.....	162	15,614	9,102	161	51,945	15,277			
Virginia.....	173,929	16,290,508	6,145,236	169,621	35,100,693	6,882,276			
West Virginia.....	89,996	5,543,096	2,238,696	89,750	19,159,008	3,672,193			
North Carolina.....	226,845	15,227,685	4,496,767	226,116	23,556,124	4,256,769			
South Carolina.....	148,552	8,811,348	2,548,179	147,919	11,049,468	2,162,797			
Georgia.....	248,072	14,930,716	4,119,870	247,183	20,793,359	3,971,760			
Florida.....	41,634	2,461,358	1,006,198	41,352	6,380,956	1,379,878			
<i>East South Central:</i>									
Kentucky.....	234,257	19,247,287	6,937,008	233,480	44,313,377	7,605,116			
Tennessee.....	225,076	17,415,208	5,774,175	224,480	42,043,104	7,258,146			
Alabama.....	225,009	12,467,486	3,168,471	224,359	22,234,713	3,762,445			
Mississippi.....	223,228	12,069,856	3,249,224	222,537	20,542,487	3,657,657			

POULTRY STATISTICS

FOWLS AND EGGS PRODUCED ON FARMS IN THE UNITED STATES IN 1909
(Continued)

Division or State	Fowls Raised			Eggs Produced		
	Farms Report- ing	Number	Value	Farms Report- ing	Dozens	Value
<i>West South Central:</i>						
Arkansas.....	186,359	10,808,758	\$2,868,562	185,627	27,054,674	\$4,459,272
Louisiana.....	100,235	6,337,010	1,943,515	99,562	14,657,544	2,448,502
Oklahoma.....	170,158	16,264,003	5,388,133	169,657	46,000,600	7,544,445
Texas.....	360,683	25,656,356	7,481,165	359,741	77,845,047	11,943,546
<i>Mountain:</i>						
Montana.....	17,914	1,432,741	797,450	17,808	6,004,051	1,610,766
Idaho.....	23,884	1,653,272	800,700	23,749	6,492,270	1,548,431
Wyoming.....	7,526	519,169	260,538	7,448	2,091,716	501,386
Colorado.....	35,102	2,706,945	1,393,039	34,902	10,652,396	2,444,006
New Mexico.....	20,538	932,045	367,907	20,305	2,976,233	683,441
Arizona.....	5,179	392,286	225,640	5,112	1,744,081	530,746
Utah.....	17,822	971,917	412,359	17,719	4,672,866	999,959
Nevada.....	2,023	190,815	115,510	2,009	870,489	263,813
<i>Pacific:</i>						
Washington.....	45,703	3,722,257	1,873,608	45,485	16,472,575	4,311,291
Oregon.....	37,696	2,655,492	1,416,608	37,579	11,906,903	2,912,849
California.....	67,306	8,430,968	4,420,515	66,857	41,022,395	10,262,694

the Middle Atlantic division reports a higher total value of eggs than any of the southern divisions. In the former, the number of fowls raised was 59,066,127, valued at \$17,681,375. The eggs produced amounted to 165,557,865 doz., and the value to \$26,395,765. The average value per fowl was 30c.; and of eggs, 16c. per doz.

The poultry production in the Middle Atlantic division, 36,313,031 fowls, was valued at \$21,527,077, or an average of 59c. per fowl; and the 161,921,598 doz. eggs produced were valued at \$37,507,552, or an average of 23c. per doz.

Production of Poultry and Eggs by States.—The production of fowls and eggs on farms by states during 1909 is shown in the table.

Seven states in the country raised over 20,000,000 fowls in 1909, namely: Illinois, Missouri, Iowa, Texas, Kansas, Ohio, and Indiana, their combined production comprising over 39% of the poultry produced in the United States. Only four states, however, reported a production of over 100,000,000 doz. eggs: Missouri, Iowa, Ohio, and Illinois, their combined product representing over 26% of the total.

Illinois raised 32,352,888 fowls in 1909, with a total value of \$15,404,028, an average of 48c. per fowl. The production of eggs amounted to 100,119,418 doz., valued at \$18,940,454, an average value of 19c. per doz.

The production of poultry in Missouri amounted to 31,913,210 fowls, valued at \$14,572,585, or an average of 46c. per fowl. This state reported a production of 111,816,693 doz. eggs, having a total value of \$19,345,602, or an average value of 17c. per doz.

Iowa with a production of 29,990,147 fowls, ranks third among the states. The total value of its poultry was \$13,914,985, or an average of 46c. per fowl. A total of 109,760,487 doz. eggs were produced in 1909, valued at \$19,235,600, or an average of 18c. per doz.

The 23,433,005 fowls raised in Ohio were valued at \$10,997,633, the average value per fowl amounting to 47c. This state produced 100,889,599 doz. eggs, having a total value of \$19,748,658, or an average value of 20c. per doz.

**RECEIPTS OF EGGS AT SEVEN LEADING MARKETS IN THE UNITED STATES,
1891-1911**

Year	Boston Cases	Chicago Cases	Cin- cin- nati Cases	Mil- wau- kee Cases	New York Cases	St. Louis Cases	San Fran- cisco Cases	Total Cases
1891	641,203	1,508,417	262,694	90,558	1,867,881	501,313	169,022	5,040,888
1892	688,227	1,955,696	272,661	80,395	2,022,008	469,216	176,964	5,665,167
1893	718,653	1,718,061	318,881	83,432	2,113,180	562,359	157,190	5,671,756
1894	781,918	2,097,179	321,011	97,557	2,323,511	598,773	162,712	6,382,661
1895	781,812	2,115,974	267,494	102,773	2,243,349	654,938	164,407	6,330,747
1896	875,518	2,301,499	361,265	106,565	2,633,932	796,490	164,732	7,240,001
1897	912,712	1,962,134	339,457	115,866	2,719,987	894,906	181,407	7,126,289
1898	898,216	2,147,950	306,423	115,652	2,542,090	898,984	203,380	7,103,695
1899	900,219	2,096,100	389,543	110,696	2,624,424	751,224	237,355	7,109,561
1900	986,367	2,475,473	414,623	118,036	2,799,937	920,682	183,563	7,898,681
1901	1,040,555	2,783,709	493,218	128,179	2,909,194	1,022,646	277,500	8,655,001
1902	1,053,165	2,659,340	464,799	114,732	2,743,642	825,999	285,058	8,146,735
1903	1,164,777	3,279,248	338,327	129,278	2,940,091	959,648	335,228	9,146,597
1904	1,122,819	3,113,858	377,263	166,409	3,215,924	1,216,124	319,637	9,532,034
1905	1,395,385	3,117,221	420,604	159,990	3,477,638	980,257	307,243	9,858,338
1906	1,709,531	3,583,878	484,208	187,561	3,981,013	1,023,125	137,074	11,106,390
1907	1,594,576	4,780,356	588,636	176,826	4,262,153	1,288,977	379,439	13,070,963
1908	1,436,786	4,569,014	441,072	207,558	3,703,990	1,439,868	347,436	12,145,724
1909	1,417,397	4,557,906	519,652	160,418	3,903,867	1,395,987	340,185	12,295,412
1910	1,431,686	4,492,483	504,739	169,352	4,377,413	1,368,280	469,698	12,813,651
1911	1,441,748	4,707,335	605,131	170,850	5,016,721	1,736,803	588,052	14,256,640

Averages:									
1891-1895...	722,363	1,879,065	288,548	90,943	2,113,946	557,320	166,059	5,818,244	
1896-1900...	912,807	2,196,631	362,262	113,327	2,664,074	852,457	194,087	7,295,645	
1901-1905...	1,155,340	2,990,675	418,842	139,718	3,057,298	1,000,935	304,933	9,067,741	
1906-1910...	1,517,995	4,396,727	507,661	180,343	4,045,687	1,303,247	334,766	12,286,426	
1911, by m'nths:									
January.....	26,708	150,534	19,412	2,973	255,316	72,347	35,310	562,600	
February.....	66,674	190,203	60,007	4,784	367,755	144,652	42,634	876,709	
March.....	157,773	522,578	101,662	16,137	636,407	249,572	68,783	1,752,912	
April.....	233,114	769,663	104,818	31,272	775,904	270,878	71,950	2,257,599	
May.....	294,577	812,434	78,024	39,381	847,759	237,454	72,884	2,382,513	
June.....	224,638	693,276	45,301	20,790	550,088	189,960	54,492	1,778,545	
July.....	128,364	456,327	30,949	14,169	343,439	122,804	51,928	1,147,980	
August.....	118,686	429,900	26,134	16,556	398,670	111,117	56,657	1,157,720	
September...	68,961	281,388	29,071	10,111	320,830	95,537	37,568	843,466	
October.....	53,137	199,827	36,467	6,496	256,233	85,121	32,438	669,719	
November...	36,741	125,268	25,686	4,754	135,594	85,358	31,149	444,550	
December...	32,375	75,937	47,600	3,427	128,726	72,003	32,259	392,327	

EGG PRODUCTION AS INDICATED BY MARKET RECEIPTS

According to the census figures, the production of eggs increased 23% from 1899 to 1909; but the commercial movement shows a much greater increase. Seven cities combined (New York, Boston, Chicago, St. Louis, Cincinnati, Milwaukee, and San Francisco), as shown in the preceding table, received about 369 million doz. eggs in 1909, an increase of 70% over their receipts in 1899. Population had increased between 1900 and 1910 about 21% in the United States, but 31% in the seven cities named above. The receipts at these seven cities in 1909 were equivalent to about 23% of the production as reported by the census, as compared with 16% in 1899.

MONTHLY RATE OF EGG PRODUCTION AND MARKETING AND VARIATIONS IN PRICES

Monthly Rate of Egg Production.—As shown in the following table, the production of eggs varies considerably from month to month. A record made from a large number of flocks in the past several years, covering various portions of the United States, shows that for every 1,000 eggs produced in a year approximately 66 are laid in Jan., 71 in Feb., 124 in Mar., 134 in Apr., 133 in May, 107 in June, 96 in July, 86 in Aug., 62 in Sept., 42 in Oct., 31 in Nov., and 48 in Dec. A good laying hen ought to produce 200 eggs a year, but the average run of hens do not produce much, if any, more than 100 a year.

Monthly Rate of Marketing of Eggs.—For every 1,000 eggs marketed (based upon receipts at New York, St. Louis, and Milwaukee in the last 10 yr.) approximately 33 are marketed in Jan., 47 in Feb., 128 in Mar., 168 in Apr., 153 in May, 119 in June, 87 in July, 76 in Aug., 64 in Sept., 53 in Oct., 39 in Nov., and 33 in Dec.

Variations in Prices of Eggs.—If the sum of the monthly index figures of prices (average prices of fresh

**MONTHLY RATE OF PRODUCTION, MARKETING, AND VARIATION IN PRICES
OF EGGS**

Month	Mean Relative Production	Mean Relative Marketing			Average Farm Price in U. S.	Mean Relative Price of Fresh Eggs in 12 Cities	
	Per Cent.	1902-1911 Per Cent.	1893-1901 Per Cent.	1880-1892 Per Cent.	1909-1911 Cents per Doz.	1902-1911 (1)	1880-1893 (1)
January.....	6.6	3.3	4.5	3.3	30.3	126.0	131.9
February.....	7.1	4.7	5.7	5.5	25.6	105.9	113.2
March.....	12.4	12.8	13.4	12.5	19.8	84.8	87.4
April.....	13.4	16.8	15.2	14.0	16.8	78.0	75.0
May.....	13.3	15.3	13.2	12.2	17.0	77.8	75.0
June.....	10.7	11.9	10.4	10.3	17.1	77.2	76.8
July.....	9.6	8.7	8.2	8.1	17.0	80.4	74.5
August.....	8.6	7.6	7.0	7.3	17.4	89.6	83.0
September.....	6.2	6.4	6.3	7.0	19.0	100.7	99.0
October.....	4.2	5.3	6.1	8.1	21.5	112.0	112.8
November.....	3.1	3.9	5.6	7.2	24.5	128.2	128.8
December.....	4.8	3.3	4.4	4.5	28.7	134.8	136.0
Year.....	100.0	100.0	100.0	100.0	19.3		

¹ Mean monthly price = 100.

eggs at 12 cities, 1902-1911) for the year is represented by 1,000, the index price will be approximately 105 for Jan., 89 for Feb., 71 for Mar., 66 for Apr., 65 for May, 64 for June, 67 for July, 75 for Aug., 84 for Sept., 94 for Oct., 107 for Nov., and 113 for Dec.

Letting 100 represent the average price paid to farmers of the United States in the month when prices are lowest, the average on the first of each month in the last 3 yr. was 180 on Jan. 1, 153 on Feb. 1, 118 on Mar. 1, 100 on Apr. 1, 102 on May 1, 102 on June 1, 101 on July 1, 104 on Aug. 1, 113 on Sept. 1, 128 on Oct. 1, 146 on Nov. 1, and 171 on Dec. 1. In quality country-shipped eggs are frequently freshest in spring when prices decline rapidly and poorest in late summer and fall when prices tend upwards, causing a disposition to hold.

In Jan., 1910, and again in June, 1910, the United States Department of Agriculture made an investigation through its agents, in 63 cities throughout the United States, concerning the price which retail dealers were paying for eggs and the price which consumers were paying for fresh eggs; at the same time inquiries were made through correspondence with crop reporters of the Bureau of Statistics adjacent to these cities concerning the prices received by producers. From the reports received it appears that in June, 1910, consumers paid an average of 24c. per doz.; retail dealers paid 19.8c., and near-by producers received 18.7c; in Jan., 1910, consumers paid 38.1c., retailers paid 32c., and near-by producers received 30.4c. The average price to producers for the entire United States in the middle of June, 1910, was about 18.3c., and in the last week of Jan., 1910, about 29c.

Influence of Cold Storage on Egg Prices.—Cold storage of eggs has developed into an important trade factor in the last 15 yr. approximately. It is generally assumed that its influence is toward a leveling of prices; that is, tending to raise prices of eggs in the spring, when they are plentiful and cheap, and to keep down

the price in winter when the natural supply is small and prices high. An examination of egg quotations in the New York market in the last 30 yr., dividing them into two periods of 15 yr. each, shows that for the grade classed as "State" the range in the more recent period was 14.8c. per doz. (i. e., from 31.3c., the average Dec. price, to 16.5c., the average Apr. price); while in the earlier period the difference was only 12.8c. (from 27.9c., the average Dec. price, to 15.1c., the Apr. price), prices being highest in Dec. and lowest in April. If the grade called "Westerns," is selected, it is found that the range in price in the recent period is 11.5c. (26.5c. in Dec., 15c. in Apr.), whereas in the earlier period the range was 11.9c. (26.6c. in Dec., 14.7c. in Apr.). If an examination is made of the Cincinnati quotations for 30 yr., divided likewise into two periods of 15 yr. each, the range in the recent period is 12.1c. (from 24.9c., the highest monthly average, to 12.8c., the lowest), whereas in the earlier period the range was only 11c. (from 21.8c. to 10.8c.). It does not appear from these figures that there has been a marked leveling or narrowing of prices between the two periods. If the statistics of movement, however, be examined, it is found that relatively more eggs are marketed in the spring months in proportion to the total yearly marketings in recent years than formerly. The receipts of eggs at New York during Mar., Apr., and May for the 15 yr. 1896-1910 were about three times greater than similar receipts in Nov., Dec., and Jan.; whereas for the preceding 15-yr. period a similar comparison shows the receipts in Mar., Apr., and May only two and two-tenths times larger than in the corresponding Nov., Dec., and Jan. Coincident with the development of the cold-storage business has been increasing facilities for transporting eggs long distances, thus broadening the sources of supply of cold-storage centers; large quantities of eggs are now shipped from Kansas and other western points to New York, and this has probably resulted in offsetting the expected tendency of cold

WHOLESALE PRICE OF EGGS PER DOZEN, 1896-1911

Date	Chicago		Cincinnati		St. Louis		Milwaukee		New York	
	Fresh		Average Best Fresh		Average Best Fresh		Fresh		Average Best Fresh	
	Low Cents	High Cents	Low Cents	High Cents	Low Cents	High Cents	Low Cents	High Cents	Low Cents	High Cents
1896.....	7½	22	7	17	6	19	7½	22	10½	25
1897.....	8	22	7	17	6	18	8	20	9½	25
1898.....	8½	26	8	20	8	20	8½	23	10	27
1899.....	10	35	8½	24	9	22	10	30	12½	35
1900.....	10	26	9	22	8	23	10	24	12	29
1901.....	10	28	9	27	6	25	10	24	13	31
1902.....	13¾	32½	13	32	11½	32	13½	30	15½	37
1903.....	10	30	12	28	11	28½	12½	27	15	45
1904.....	11	34½	14½	32	13	29	13½	32	16	47
1905.....	12	36	14	30	10½	34	14	31	16½	40
1906.....	11	36	13	29	11½	26	12½	33	14½	45
1907.....	13,	30	13½	29	12	25½	12½	28	16	50

1908	21	30	19	26	18	21	20	24	23	38
January.....	19 ½	27	18	23	17	23	17	22	20	32
February.....	14	22 ½	13	18	13	17	13 ½	20	15	29
March.....	14 ¼	16 ¼	13	14	13	13	13 ½	20 ½	15 ½	20
April.....	14 ½	17	13 ½	15 ½	13	14	13 ½	13 ½	16 ½	21
May.....	14	17 ½	13 ½	17	14	14	13 ½	14	15	24
June.....	15 ½	19 ½	14	17	12 ½	14 ½	14 ½	17 ½	17	26
July.....	17 ½	20 ½	14	21	14 ½	16	16 ½	17 ½	18	30
August.....	19	23	19	24	16	18 ½	16 ½	19	19	35
September.....	22	27	22	28	18 ½	23	19	24	22	44
October.....	26	30	23	34	23	27	25	28	24	50
November.....	28	33	25	36	25	29	28	32	28	55
December.....										
Year.....	14	33	13	36	12 ½	29	13	32	15	55
1909	24	36	28	36	26	38	15	30	29	40
January.....	20	35	21	37	21	40	16	32	24	40
February.....	17 ½	20 ½	17	20	16	18 ½	14	21	19	25
March.....	18 ½	20 ½	20	22	18	20	14	19 ½	20 ½	25
April.....	19	23	20	22	18	20	15	19 ½	22	25
May.....	17 ½	21 ½	19 ½	21 ½	17 ½	19	15	19 ½	21 ½	26 ½
June.....	18	22 ½	20 ½	22 ½	17	19 ½	15	20 ½	23	29
July.....	19	23	20	23	17	19 ½	15	20 ½	23	32
August.....	19	24	23	24	18	19	15	20 ½	24	34
September.....	20	27	23	28 ½	21	23 ½	15	21 ½	25	37
October.....	23	30 ½	29	31 ½	23 ½	27	15	24	25	50
November.....	26 ½	36 ½	28	35	25 ½	31	15	30	25	55
December.....							15	34	30	53
Year.....	17 ½	36 ½	17	37	16	40	14	34	19	55

POULTRY STATISTICS

WHOLESALE PRICE OF EGGS PER DOZEN, 1896-1911—(Continued)

Date	Chicago		Cincinnati		St. Louis		Milwaukee		New York	
	Fresh		Fresh		Average Best Fresh		Fresh		Average Best Fresh	
	Low Cents	High Cents	Low Cents	High Cents	Low Cents	High Cents	Low Cents	High Cents	Low Cents	High Cents
1910										
January.....	31 1/2	38	32 1/2	40	28 1/2	35	15	26	32	50
February.....	23 1/2	31	23	30	22	26 1/2	15	28	27	40
March.....	18 1/2	24 1/2	19 1/2	22 1/2	19	23	12	22	22	30
April.....	19 1/2	22	19 1/2	20 1/2	19	20 1/2	15	19	23	26
May.....	17 1/2	20 1/2	18	20	17	19 1/2	13	18 1/2	23	27
June.....	17 1/2	19 1/2	19	19 1/2	14 1/2	17 1/2	12	17 1/2	22	28
July.....	15	19 1/2	17	19	15	17 1/2	10	17 1/2	23	33
August.....	15	22	18 1/2	22 1/2	17 1/2	21	10	20	25	33
September.....	20	24	23 1/2	24	21	23	10	23	25	40
October.....	23	27	25	29	21 1/2	24	12	25	30	48
November.....	26	31	30	34 1/2	24	27 1/2	14	30	35	55
December.....	28	33	36	38	27	29 1/2	15	30	36	55
Year.....	15	38	17	40	14 1/2	35	10	30	22	55

**AVERAGE PRICE RECEIVED FOR EGGS BY FARMERS ON THE FIRST OF EACH
MONTH OF 1911**

State and Division	Cents Per Dozen											
	Jan.	Feb.	Mar.	Apr.	May	June	July	Aug.	Sept.	Oct.	Nov.	Dec.
Me.....	38	28	22	19	17	18	20	22	27	28	34	40
N. H.....	39	27	26	21	20	20	22	25	30	32	35	41
Vt.....	39	28	22	19	18	18	19	22	26	28	30	40
Mass.....	43	35	29	24	23	25	26	30	34	34	40	49
R. I.....	48	35	28	21	22	25	27	30	35	37	41	50
Conn.....	45	30	26	21	20	22	27	32	32	37	40	50
N. Y.....	41	28	23	19	17	18	19	23	25	27	33	38
N. J.....	44	28	23	20	19	21	21	24	28	30	34	41
Pa.....	37	25	20	18	16	17	18	20	21	25	29	35
Del.....	40	22	20	16	17	16	18	18	19	23	30	37
Md.....	34	20	17	15	16	15	16	18	19	22	26	32
Va.....	29	19	16	15	15	15	15	16	18	20	23	27
W. Va.....	31	23	17	17	16	16	16	17	18	20	22	28
N. C.....	25	19	15	14	15	14	16	16	17	20	21	23
S. C.....	29	23	18	17	18	17	19	17	20	22	24	25
Ga.....	28	23	18	17	17	17	17	17	18	21	24	26
Fla.....	32	24	20	20	20	20	21	21	22	24	28	31
Ohio.....	34	20	16	15	15	14	14	16	18	20	25	31
Ind.....	30	19	14	14	14	13	13	14	16	19	23	30
Ill.....	29	21	15	14	14	14	13	14	15	18	22	28
Mich.....	29	24	18	15	15	15	15	16	17	20	24	24
Wis.....	30	25	17	15	15	15	14	15	16	18	22	26
Minn.....	30	23	16	14	14	14	12	14	16	18	22	27

Iowa.....	26	21	14	13	14	13	12	12	12	12	11	14	17	20	25
Mo.....	26	18	13	12	13	12	10	10	10	10	11	13	16	19	26
N. Dak.....	30	29	22	15	13	14	13	13	12	13	15	17	18	22	26
S. Dak....	29	25	16	13	13	13	13	13	13	14	14	16	18	21	27
Neb.....	26	19	14	13	12	12	11	11	11	12	12	14	16	20	26
Kans.....	26	18	13	13	13	12	10	10	11	11	11	14	16	20	26
Ky.....	28	18	13	13	13	12	12	12	13	13	13	14	17	19	26
Tenn.....	26	18	13	13	13	13	12	12	12	13	13	15	17	18	24
Ala.....	27	21	15	14	14	14	14	14	14	14	15	16	18	20	23
Miss.....	26	21	16	15	15	14	14	14	15	15	15	17	19	20	22
La.....	27	22	17	15	16	14	14	14	16	16	16	17	19	22	22
Tex.....	25	20	14	13	12	12	12	12	12	12	12	14	17	18	22
Okla.....	26	20	14	12	12	11	11	11	11	11	11	14	16	20	25
Ark.....	26	20	14	12	14	13	11	11	14	14	14	16	18	18	22
Mont.....	45	42	34	26	22	21	25	25	25	25	25	29	33	33	39
Wyo.....	41	34	23	22	19	19	19	19	23	23	23	27	27	31	34
Colo.....	36	31	24	19	17	18	19	19	21	21	21	23	26	28	34
N. Mex.....	35	32	25	24	21	21	24	24	24	24	24	28	29	31	36
Ariz.....	44	36	30	29	26	30	27	27	30	30	30	32	36	35	41
Utah.....	35	29	22	16	16	16	16	16	18	18	18	21	23	25	30
Nev.....	52	45	35	32	29	29	28	28	31	31	31	34	41	44	46
Idaho.....	41	34	30	22	19	20	22	22	24	24	24	26	28	31	35
Wash.....	42	34	27	21	20	21	22	22	25	25	25	29	31	35	40
Ore.....	42	36	27	23	21	22	22	22	25	25	25	28	28	32	40
Cal.....	38	31	24	18	18	20	22	22	23	23	23	27	33	38	42

storage to narrow the range of prices. If monthly prices could be readily obtained from a number of interior western and southern points for the last 30 yr. probably a narrower range between high prices and low prices would be found.

Variations in Wholesale Prices of Eggs.—The wholesale prices of eggs per dozen between 1896-1911 are shown in the table on pages 262-265.

Variation in Average Price of Eggs Received by Farmers.—The variation in the average price of eggs received by farmers of the different states on the first of each month of 1911 is shown in the preceding table.

GLOSSARY OF TECHNICAL TERMS USED BY POULTRYMEN

A clear understanding of the meaning of the technical terms used in the poultry world is necessary before any person can judge fowls according to Standard requirements or select them for breeding purposes or the show pen or even converse intelligently on the subject of poultry.

In order to impart a clear understanding of the terms applied to the different parts of a fowl, a profile view of one is shown in Fig. 1, with the different parts numbered. Following this will be found a list of the names of the numbered parts. Farther on is a list of technical terms and expressions used by poultrymen. Some of the terms are peculiar to England and some to certain parts of the United States, but the meaning of each is fully explained and many are made clear by illustrations

Abdomen.—The part of the body of a fowl that contains the viscera. See 32, Fig. 1.

Albino.—A fowl that is pure white in all parts except the eyes, due to the absence of coloring pigment; a sport from black or colored fowls.

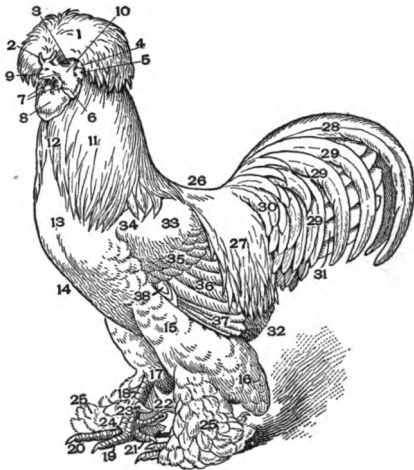

FIG. 1

NAMES OF NUMBERED PARTS

- | | |
|------------------------------|-------------------------------------|
| 1, Crest | 21, Fourth toe |
| 2, Comb | 22, Fifth toe |
| 3, Eye | 23, Spur |
| 4, Feathers covering the ear | 24, Foot |
| 5, Ear lobe | 25, Shank and toe feathering |
| 6, Muff | 26, Back |
| 7, Wattles | 27, Saddle |
| 8, Beard | 28, Sickles |
| 9, Beak | 29, Lesser sickles |
| 10, Face | 30, Tail coverts |
| 11, Hackle | 31, Main tail |
| 12, Neck | 32, Abdomen |
| 13, Breast | 33, Wing bow |
| 14, Breastbone, or keel | 34, Shoulder |
| 15, Thigh | 35, Wing bar |
| 16, Vulture hock | 36, Wing bay, or secondary feathers |
| 17, Hock joint | 37, Primary, or flight, feathers |
| 18, Shank | 38, Primary coverts |
| 19, Third toe | |
| 20, Middle toe | |

Amateur.—A person not well informed about the art of poultry raising; a beginner; a novice.

Antler Comb.—A comb composed of two small prongs somewhat resembling antlers; a V-shaped comb; common in Polish, La Flèche, and some strains of Houdans. Fig. 2.



FIG. 2

A. O. C.—Any other color.

A. O. V.—Any other variety.

Atavism.—Recurrence to an ancestral type or to a deformity or disease after its disappearance for several generations; reversion.

Band.—(1) A stripe or marking of any kind at the end of or across a feather. (2) A band of metal or other material, usually stamped with numbers or letters, or colored, for attaching to the shank of a fowl so that it can be identified.

Bantam.—A dwarf, or pigmy, fowl, usually about one-fifth the size of a large fowl of the variety to which it corresponds in every particular except size.

Barb.—One of the side branches of a feather, which collectively make up the web and fluff. See feather.

Barring.—Bands of alternate colors that extend across a feather. Fig. 3.

Barred to the Skin.—An expression applied to fowls whose feathers are barred from the tip to the end of the fluff, as in Barred Plymouth Rocks.

Bay.—A reddish-brown color, approaching chestnut; also used to designate eyes in fowls that have an approach to blood-red color.

Beak.—As used by poultrymen, the beak is the bony formation extending from the front of the head of chickens and turkeys; it consists of the upper and lower mandibles. See 9, Fig. 1. The corresponding part of water fowls is called the bill.



FIG. 3

Bean.—A growth, resembling a thumbnail, on the point of the upper mandible of the bill of a duck, as shown at *a*, Fig. 4. A like growth of a smaller size is found on the bill of a goose.

Beard.—(1) A tuft of feathers under the beak and about the throat of such fowls as Polish, Houdans, etc. See 8, Fig. 1. (2) A tuft of hair growing on the breast of turkeys.



FIG. 4

Beefy.—A term applied to coarse, overgrown combs; such combs are more commonly found on Mediterranean fowls than on those of other varieties.

Beetle Brows.—See brows.

Bib.—The English name for beard.

Bill.—The mandibles of water fowls, which correspond to the beak in other domestic fowls.

Bird.—Fowl was the term formerly applied to all winged creatures; modern usage restricts the name fowl to the larger domesticated fowls and designates the smaller wild fowls as birds. However, the term bird is frequently indiscriminately used instead of the term fowl.

Blade.—The rear part of a single comb, generally called the heel. See *b*, Fig. 25.

Blocky.—A term applied to a fowl that is of heavy and square build; said of a fowl that is broad, or wide, between the thighs. Compare with cobby, an English term that expresses the same meaning.

Bloom.—The gloss, sheen, or finish on the plumage of fowls.

Body.—Fanciers usually apply the term body to the trunk of a fowl only.

Booted.—Fowls that are feathered on the shanks and toes are said to be booted.

Bouquet Crest.—A crest that stands up from the head and to some extent resembles a bouquet of flowers; found on crested ducks. At one time, a bad defect in Polish fowls.

Brassiness.—A term applied to a yellow or yellowish tint commonly found in the feathers of white fowls and sometimes in the feathers of dark-plumaged fowls.

Breast.—(1) A term applied to that part of the front of the body of live fowls that extends from the throat to the point of the breastbone. See 13, Fig. 1. (2) The term is applied also to the meat on both sides of the breastbone of fowls prepared for the table.

Breed.—A family of fowls all of which are of the same distinctive shape. A breed may include a number of varieties, the fowls of all the varieties having the same shape but being distinguished by different plumage colors and markings.

Breeding Down.—A term applied to the process of producing small, or bantam, fowls from larger fowls by selecting and breeding the smallest fowls obtainable—a process usually involving breeding through a number of generations.

Brick Color.—A reddish-brown color occasionally found on fowls of black-red varieties.

Broken Colored.—See mottled and spangled.

Brood.—A number of chicks that are mothered by one hen or kept in one brooder.

Broody.—When a hen shows a desire to sit, that is, to hatch eggs, she is said to be broody.

Brows.—The projection of the skull over the eyes of a fowl, as in Asiatic and Malay fowls; termed beetle brows in England. Fig. 5.



FIG. 5

Cap.—The upper part of a fowl's skull or comb; a term used in England.

Cape.—The feathers between the shoulders and about the neck underneath the hackle.

Capon.—A castrated cock or cockerel; that is, a male from which the reproductive organs have been removed; a female from which the reproductive organs have been removed is called a poulard.

Carriage.—The general appearance, pose, or bearing of a fowl; the way in which a fowl carries itself when walking.

Caruncles.—Irregular growths of flesh such as occur on the head and neck of turkeys and Muscovy ducks. Fig. 6.

Carunculated.—Covered with caruncles.

Castrate.—To remove the testicles, the organs of reproduction, from a male fowl.

Cavernous.—Said of nostrils that are prominent and deeply hollowed. Such nostrils are found on crested fowls. Fig. 7.

Chain Armor.—Faulty lacing on the claret-colored breast of a Rouen drake.

Chick.—One of the newly hatched young of fowls or birds.

Chicken.—Specifically, a fowl less than 1 yr. old; commonly, a fowl of any age.

Cinnamon Color.—A dark reddish buff, formerly admissible on one variety of Cochins.

Claret Color.—Descriptive of the breast color of a Rouen drake.

Clean Legged.—A term used in describing a fowl that has no feathers on its shanks or toes.

Close Feathered.—See tight feathered.

Cloudy.—A term applied to plumage that has irregular markings. See mossiness.

Clutch.—The number of eggs a domestic fowl incubates, or sits on, at one time, usually from 11 to 15. See sitting.

Coat.—The plumage of a fowl taken as a whole.

Cob.—A male swan.

Cobby.—A term applied in England to a fowl that is thick set, heavily built, and round in form. See blocky.

Cock.—A male fowl more than 1 yr. old; the term is commonly applied to pit game cocks of any age.

Cockerel.—A male fowl less than 1 yr. old. The practice in the show room is to allow males to be shown as



FIG. 6



FIG. 7

cockerels during the entire show season that follows their hatching. Compare with pullet.

Cockerel Bred.—Bred in line from a mating made expressly for producing cockerels for exhibition. Both males and females from such matings are said to be cockerel bred. Compare with pullet bred.

Collar.—A white ring around the neck, as in Rouen ducks and in pheasants.

Color.—A term applied to any one of the many hues that may be found on the feathers or on any other part of the body of a fowl. This term is used also in describing the coloring of the entire plumage. A fowl is said to have good color when each of its colors is of the proper tint and is found in its proper place, and to have bad color when the reverse is true.



FIG. 8

Comb.—The fleshy growth on the top of the head of a fowl. See 2, Fig. 1, and Figs. 2, 5, 16, 20, 22, 25, and 30.

Comb Over.—An expression for lopped comb; used in England. Figs. 8 and 24.

Comparison Judging.— Judging fowls by comparing them with one another, and without applying a score card.

Concave Sweep.—The continuous curve of the back from the shoulder to the tail; required in some breeds.

Condition.—The state of the health and plumage of a fowl; sometimes applied only to the finish, or appearance, of the plumage.

Conditioning.—The process of preparing a fowl for the show room.

Coverts.—Feathers that grow about the tail; also the secondary quill feathers. See 30 and 38, Fig. 1, and wing and tail coverts and hangers.

Cradle Comb.—A term formerly applied to the Wyandotte comb; at present little used. Same as rocker comb.

Creaminess.—A term descriptive of white feathers that are tinged with a slight yellow or cream color.

Crest.—A tuft of feathers on top of the head. Figs. 9 and 16.

Crop.—An enlarged part of the gullet, or pouch, in which food is stored and softened prior to passing into the gizzard.

Crop Bound.—A term applied to an unnatural condition of the crop, in which that organ is stopped up and food is prevented from passing through it.



FIG. 9

Cross.—A mating of fowls of different breeds.

Cross-Bred.—The offspring from two fowls of different breeds; as from mating a Plymouth Rock and a Rhode Island Red.

Curl Feather.—One of the set of curled feathers near the base of the back of a male duck.

Curve.—Any arched or concave line on the body of a fowl, such as the curve of the back, the curve formed by the flowing tail feathers, or the arched shape of the neck in water fowls.

Cushion.—A raised mass of plumage due to an excessive development of soft feathers about the tail of Cochins and some other fowls.

Cushion Comb.—The name applied in England to the comb of the Silky; a circular cushion of flesh with a number of small protuberances on it. Same as strawberry comb.

Cut.—A deduction made from the score of a fowl; as a cut of 2 points.

Cygnets.—A young swan.

Daw Eyed.—A term used at one time to describe game fowls that had peculiar eyes resembling those of a jackdaw, which were of a pearl color; pigeons with eyes of the same kind are said to be pearl eyed.

Deaf-Ear.—The ear lobe.

Debarred.—Barred from competition.

Deep Bodied.—Said of fowls that have a good depth of body from the top of the back to the lower side of the breastbone.

Defect.—Any blemish, imperfection, fault, or lack of some feature or quality.

Dewlap.—A growth of loose skin below the beak or bill, as in Brahmas and water fowls. Fig. 5.

Diamond.—An expression formerly used in place of wing bay. See 36, Fig. 1.

Dished.—When hollows or depressions appear in the bill of a water fowl, it is said to be dished. See *b*, Fig. 4.

Disqualification.—A defect that will debar a fowl from competition.

Disqualified.—Condemned; unfit for exhibition.

Double Comb.—A term formerly applied to all combs except the single comb.

Double Lacing.—A double ring or penciling about the outer edge of a feather. Fig. 10. See supplementary lacing.



FIG. 10

Double Mating.—A system of mating in which males fit for exhibition are produced from one pair of breeding fowls, and females fit for exhibition are produced from another pair.

Down.—(1) The first downy covering of young chicks. (2) The soft cottonlike part of a feather below the web. See *b*, Fig. 12. (3) A mosslike growth between the toes.

Drake.—A male duck.

Dubbing.—The cutting off of the comb, wattles, and ear lobes of game fowls.

Duck.—A species of water fowl, including both sexes; also, a female of the species, as distinguished from the male.

Duckling.—A young duck.

Duck Foot.—See web foot.

Duck Footed.—A fowl is said to be duck footed when the back toe is carried close to the other toes, instead of being well spread out behind. Fig. 11.

Ear Lobe.—The fleshy growth below the ear; this may be red, white, or other color, according to the variety. Same as deaf-ear. See 5, Fig. 1.

Eggs for Hatching.—Eggs that are suitable for incubation.

Exhibition Fowls.—A fowl suitable for exhibition in a show room.

Face.—On a fowl, the part of the head about the eyes that is bare of feathers.

Faking.—A term equivalent in meaning to deceiving; it is in frequent use by poultrymen. Faking consists in re-

moving or dyeing objectionable feathers, in coloring shanks and feet, in removing side sprigs, or in the use of other unfair means to win a prize in a show room.

Fancier.—A breeder of poultry, pigeons, or pet stock.

Fancy.—A lax term for fanciers collectively.

Feather.—One of the appendages peculiar to and growing out of the skin of a fowl or a bird, collectively forming the plumage. Fig. 12. A feather is commonly composed of the following principal parts: *web* *a*, in which the barbs are stuck together, forming a thin, smooth sheet; the *fluff*, or *down* *b*, in which the barbs are not united; the *shaft*, quill, or barrel, which is composed of a lower hollow and tubular part *c*, and an upper part *d*, which is filled with pith.

Feather Cell.—The cell in the body from which a feather grows.

Feather Legged.—Said of fowls that have feathers growing on the sides of the shanks and toes; booted. See 25, Fig. 1.

Fillers.—The small feathers that grow between the main tail feathers.

Finish.—Gloss on plumage.



FIG. 11



FIG. 12

First-Cross Fowls.—Fowls resulting from the first crossing of standard-bred males and females of different breeds.

Flat Shin.—A flat part on the shank of a game fowl.

Flight Coverts.—Short feathers that grow at the base of the flight feathers and partly cover them. See 38, Fig. 1.

Flights, or Flight Feathers.—The primary feathers on the wing of a fowl. See 37, Fig. 1.

Flow.—Said of feathers that hang loosely or sweepingly.

Fluff.—(1) The downy or lower part of a feather; see b, Fig. 12. (2) The profuse soft feathering about the thighs and abdomen. See 32, Fig. 1.

Fluffing.—The act of bending or breaking the shafts and quills of the feathers in the fluff, cushion, and tail feathering of Asiatic Bantam and other Asiatic fowls, to build them out into unnatural size. This constitutes faking.

Folded Comb.—A comb that falls over to one side and folds back, forming a loop.

Foreign Color.—Any color found on a fowl that is not characteristic of or standard for the variety to which the fowl belongs.

Form.—As applied to fowls in the show room, form refers to their condition and finish.

Foul Feathers.—Feathers that are marked with foreign color.

Fowl.—A domestic cock, hen, cockerel, or pullet.

Foxy.—See rusty.

Frizzle Feathers.—Feathers that are crinkled or curled.

Frosting.—Irregular markings or lacing of a light color. Similar markings of a dark color give the appearance of mossiness.

Furnished.—A fowl is said to be furnished when it has a complete growth of tail, hackle, and saddle plumage, and a well-developed comb and other head points.

Furnishings.—Same as hangers.

Gaff.—A steel spur.

Gamy.—Like a game fowl; full of fight.

Gay.—A fowl is said to be gay when it has spangled, splashed, or colored plumage with an excessive amount of white on it.

Gills.—An improper name for the wattles.

Gloss.—The luster on the surface of feathers.

Gobbler.—A male turkey.

Gray.—A color produced by a mixture of black and white; it is of different shades, according to the proportions of black and white, as in the plumage of Dark Brahas and Silver-Gray Dorkings.

Ground Color.—In fowls, the main, or principal, color in the plumage; for example, in a Buff Laced Polish fowl, the buff is the ground color.

Gullet.—The opening through which food passes.

Gypsy Color.—Purple color, as found on the face of some game fowls; also called mulberry color.

Hackle Feathers.—The long, flowing feathers that grow on the neck of a fowl; more plentiful in males than in females. See *II*, Fig. 1. See *hackle*.

Hangers.—An improper name for saddle feathers.

Hatch.—(1) To produce young from, that is, to cause young to develop in and come forth from an egg by either natural or artificial incubation. (2) A brood hatched at one sitting or one incubation.

Hard Feathers.—Firm, close feathering, such as is found on game fowls.

Hen.—A mature female domestic fowl.

Hen Feathered.—Said of a male fowl with a tail like a hen, as in the males of Sebrights and some varieties of game fowls.

Hen Tailed.—Same as hen feathered.

Henny.—A term applied to a male fowl, usually a game, that has tail or other plumage resembling that of a hen.

High-in-Back.—A term used in England to describe hump or roach back.

Hock.—The joint between the thigh and the shank. See *17*, Fig. 1.

Hollowed Place in Comb.—A depression in the comb of a fowl; same as a thumb mark. Fig. 24.

Hood.—Neck feathers that curve forwards over the head.

Horn Comb.—Same as antler comb and V-shaped comb.

Horseshoe Lacing.—Lacing forming a horseshoe about the tip of a feather. Fig. 13.



FIG. 13

Hump Back.—A fowl with a hump back is one that has a knob, lump, or prominence on the back.

Hybrid.—The offspring from two birds of different *species*; as from mating a goldfinch with a canary, or a turkey with a guinea.

Ideal.—Of a perfection that is seldom realized.

Inbred Fowl.—An offspring from closely related fowls.

Inbreeding.—Breeding, or following a course of breeding, from nearly related fowls.

Incubate.—See hatch and sit.

Irregular Lacing.—Incomplete or imperfect lacing about the edge of a feather.

Jaw.—In a fowl, the jaw is that part of the head that supports the upper and lower mandibles.

Keel.—(1) The lower edge of the breastbone. (2) The loose flesh and feathers hanging below the breast in ducks and other poultry.

Knee Joint.—Same as hock joint. See 17, Fig. 1.

Knob.—The protuberance on a goose at the juncture of the head and the bill.

Knock Kneed.—A malformation of the legs of a fowl, in which the hock joints come close together instead of being well apart as they should be. Fig. 14.

Lacing.—The edging along the margin of a feather; it is usually darker in color than the body of the feather. Fig. 15.



FIG. 14

Leader.—The spike, or heel, on a rose comb—the part that extends to the rear. See *a*, Fig. 22.

Leaf Comb.—A comb consisting of two small sections, each shaped like a leaf. Fig. 16.



FIG. 15

Leggy.—A fowl is said to be leggy when it has too great length in legs.

Leg and Toe Feathering. The feathering on both the shanks and feet; booting. See 25, Fig. 1.

Lesser Sickles. — The smaller tail feathers next to the full, flowing sickles. See 29, Fig. 1.



FIG. 16

Line Breeding.—Breeding, or following a course of breeding, from a limited number of original fowls. In line breeding the fowls mated are not so closely related as those mated in inbreeding. Line breeding is really a modified form of inbreeding.

Loop.—A double fold in the comb, as in a Minorca female.

Lopped Comb.—A comb that falls over on either side. Same as comb over. Figs. 8 and 24.

Low Built.—Said of a fowl that is very short in the legs and hence carries its body close to the ground.

Lump Comb.—Same as strawberry comb.

Made Form.—The form that may be produced in a fowl by training.

Main Tail Feathers.—The stiff feathers of the tail under and between the sickles and coverts. See 31, Fig. 1.

Mandibles.—The horny upper and lower parts of the beak or bill.

Marbled.—A term used to describe ticked or laced feathers on the breast of Pyle Game cocks.

Markings.—Striping, lacing, barring, or marks of any kind on the plumage.

Mazarine.—Deep-blue or purplish markings across a black feather.

Mealy.—A term used to describe plumage that should be one solid color but is covered with irregular dots of mixed or faulty color.

Moon.—A rounded spot of color tipping the feathers of fowls of some varieties.

Mossiness.—An effect produced by irregular dark markings. Fig. 17. See frosting.



FIG. 17

Molt.—(1) To cast off or shed the feathers of fowls. (2) The act or process of molting. (3) The season or period of molting.

Mottled.—Marked with spots or blotches of different colors.

Mulberry Color.—See gypsy color.

Muff, Muffle, Muffling.—A growth of feathers on either side of the head, usually seen on bearded fowls, and very marked in Faverolles. See 6, Fig. 1.



FIG. 18

Natural Form.—The natural appearance of a fowl without training.

Non-Sitter.—A fowl that does not incubate eggs.

Novice.—A beginner; an inexperienced person.

Open Barring.—Barring in which the bars are wide apart. Fig. 18.



FIG. 19

Open Lacing.—Narrow lacing about the edge of a feather and forming a ring around a spot of another color, giving the feather the appearance of having a large open center. Fig. 19.

Overhang.—A term used by poultrymen to describe the overhanging skull as found in Aseel Game, Malay Game, and Brahma fowls. Some pigeons, also, have the same kind of a projection on the skull.

Overlap.—To lie partly over; said of the colors on plumage when they meet on a ragged edge, giving the appearance of one color overlapping another.

Parti-Colored.—Of several colors, like the Light Brahma or Houdan.

Pea Comb.—A small, low comb divided lengthwise into three parts, and having the appearance of three small single combs placed side by side, as on the Brahma and Aseel. Figs. 5 and 20.

Pearl Eyed.—See daw eyed.

Pen.—(1) An enclosure. (2) A female swan.



FIG. 20

Penciling.—Narrow lines or markings. The term penciling is applied to several kinds of markings on poultry: (1) The bars on the feathers of Penciled Hamburgs. (2) The concentric lines that follow the outline of the feather in Dark Brahmas and Partridge Cochins. Fig. 21. (3) The fine gray markings on Rouen drakes. (4) The stippling as found on Leghorns and Black-Breasted Red Game females.



FIG. 21

Pen Manners.—The behavior of fowls in pens in the show room.

Pen of Fowls.—In the show room, a pen of one male and four females.

Peppered.—Plumage is said to be peppered when it is dotted with spots.

Pile.—The spelling used in England for Pyle.

Pinion.—(1) The outermost section of the wing of a bird, bearing the pinion feathers. (2) To cut off the outer part of a bird's wing that bears a considerable proportion of the feathers used in flying, in order to prevent flying.

Pit.—An enclosed space in which fowls are pitted against each other; hence, a fighting place for fowls.

Plumage.—The feathers and down.

Point.—One of the tapering, sharp-ended serrations of the upper part of a single comb. See *a*, Fig. 25.

Poulard.—A female fowl, usually a pullet, in which the egg-producing organs have been destroyed.

Poult.—A young turkey.

Poultry.—All domestic fowls.

Prepotency.—The superiority of one parent over the other in transmitting characters to the offspring; that is, in stamping its individuality on the offspring.

Primaries.—The flight feathers. See 37, Fig. 1.

Producer.—A fowl that produces offspring better than itself.

Pullet.—A female fowl less than a year old. Show-room practice allows a fowl to be exhibited as a pullet during the entire show season that follows the hatching.

Pullet Bred.—Bred in line from a mating made expressly for producing pullets for exhibition. Both males and females from such matings are called pullet bred. Compare with cockerel bred.

Pure Bred.—Fowls that have no alien blood in them are said to be pure bred.

Purply.—The effect produced by purple bars across a black feather.

Quill.—See feather, and c, Fig. 12.

Quill Bound.—A condition in which the feather is retained in its sheath, instead of the sheath cracking and falling off.

Racy.—A fowl that is slender, trim, active, alert, or tight feathered is said to be racy.

Reachy.—Said of fowls that have an upright carriage and are tall, such as game fowls.

Ribbon.—The bright-blue band across the wings of Rouen and other ducks.

Roach Back.—A back with a hump; same as hump back.

Rocker Comb.—A term formerly applied to the Wyandotte comb; same as cradle comb.

Rooster.—Common name for a cock or a cockerel.

Rose Comb.—A broad, level comb, wide in front, tapering to a spike, or point, in the rear, and covered on

the top with small projections, or points, as in Hamburgs and Rose-Comb Bantams. Fig. 22. At *a* is shown the spike.

Rosy Wings.—Wings of Pyle females, which are marked with salmon color; wings of the same color were formerly called foxy colored.

Ruff.—Same as muff.

Rusty Color.—The reddish-brown shadings on the outside of the wings of Black-Breasted Red Game and Brown Leghorn females. In England, the same shading is called foxy.

Saddle.—That portion of the back of a male fowl between the middle of the back and the base of the tail.

Saddle Feathers.—The flowing feathers growing from the saddle of a fowl.

Saddle Hackles.—The long, flowing feathers that grow from the saddle of a male and hang down on both sides of the body; also called saddle hangers and saddle feathers. See 27, Fig. 1.

Salmon.—A reddish or pinkish orange color, like that found on the breast of Red Pyle Game females and Brown Leghorn females.

Scales.—Thin, horny growths covering the shanks and feet.

Scaly Leg.—A diseased condition of the shanks and feet, caused by the scaly-leg mite.

Secondaries.—The long quill feathers of the wings that grow on the second joint or next to and above the primaries. See 36, Fig. 1.

Section.—A distinctly defined part of a standard-bred fowl.

Self-Color.—A uniform color.

Serrated.—Notched along the edge like a saw.

Serration.—One of the points of a single comb. See *a*, Fig. 25.

Shaft.—See feather, and *d*, Fig. 12.

Shafy.—A term describing a dark-colored feather with a light shaft. Fig. 23.



FIG. 22

Shank.—That part of the leg between the toes and the hock joint. See 18, Fig. 1.



FIG. 23

Shank Feathers.—Feathers growing on the outside edge of the shank. See 25, Fig. 1.

Shank Line.—A line that would be formed by drawing a straight line along the rear edge of the shank upwards through the body of a fowl.

Sheath.—The covering over a new feather; it splits and falls off as the feather develops.

Sheen.—The glistening brightness, or gloss, on plumage.

Shoulder.—The front or upper part of the wing; it is round or bow shaped and is hidden in fowls of some breeds by the breast plumage and hackle; in game fowls it stands out prominently. See 34, Fig. 1.

Shoulder Butt.—Same as shoulder.

Show-Room Form.—The form that a fowl has in the show room.

Sickles.—The top pair of curved feathers in the tail of male fowls. One or two pairs similar to these, but below them, are called the lesser sickles. See 28 and 29, Fig. 1.

Side Spike.—Same as side sprig.

Side Sprig.—An extra point, or growth, at the side or near the end of a single comb. Fig. 24.

Silvery.—A term applied to the appearance of the shoulders of barred fowls that are deficient in barring and that have light, or silvery markings on these parts instead of the customary barring.

Single Color.—Same as whole color.

Single Comb.—A thin, serrated, fleshy growth on the top of the head of a fowl, as in Plymouth Rocks and



FIG. 24

Leghorns. Fig. 25. At *a* is one of the serrations, or points; at *b*, the blade.

Single Mating.—A mating from which both males and females fit for exhibition are produced from a single pair of breeding fowls. See double mating.

Sit.—To cover eggs for hatching; incubate.

Sitters.—Fowls that sit on and incubate eggs. The sitting proclivities are stronger in some breeds than in others. Fowls in which the sitting proclivities are weak are said to be non-sitters.

Sitting.—The act of sitting to incubate eggs; also, the number of eggs for a sitting, usually from 11 to 15. See clutch.



FIG. 26

Slipped Wing.—A wing in which the light, or secondary, wing feathers hang loose or out of place. Fig. 26.

Smooth Legs.—Legs that have no feathers, stubs, or down on the shanks.

Smut.—A term applied to dark color overlying any section of a fowl.

Solid Color.—Of one uniform color throughout; self-color.

Spangle.—A dark marking at the point, or tip, of a feather. Fig. 27.

Spike.—The rear point on a rose comb; also sometimes called a leader. See *a*, Fig. 22.

Splashed Feathers.—Feathers in which there is an uneven mixture of color.

Split Crest.—A rounded crest that is split and falls over on both sides.

Sport.—A fowl that varies from the normal type; a white offspring from black parents.

Spur.—A horny growth on the inside of the shank of a cock. See 23, Fig. 1.



FIG. 25



FIG. 27

Squirrel Tail.—A tail in which the feathers are carried so far forward as almost to touch the head, like the tail of a squirrel. Fig. 28.



FIG. 28

to which it belongs, has good symmetry, and the proper height and reach. Station is a term applied more especially to game fowls. Compare with carriage.

Steppings.—A term used in England to describe the effect produced by the ends of the secondary feathers, each one of which is shorter than the one immediately below it, giving the appearance of a flight of steps.

Stippling.—The effect produced on plumage by dots of dark and of light shades of color, as in Brown Leghorn females. Fig. 29.

Strain.—Fowls of one variety that have been bred in line for a number of generations from a few original fowls.



FIG. 29

Strawberry Comb.—A lump comb, somewhat resembling a strawberry in shape, as in Malays and Silkies. Fig. 30.



FIG. 30

Striping.—Markings of dark color that extend down the middle of a feather and taper to a point near the tip of the feather, as in Light Brahmas, Brown Leghorns, and some other fowls. Fig. 31.

Stub.—A short piece of the quill of a feather; especially, a short piece of the quill of a feather occasionally found on the shanks of smooth-legged fowls.

Style.—A fowl is said to have style when it presents a fine, spirited appearance, and has good symmetry, station, and carriage.

Supplementary Lacing.—An outside edging or lacing of a different shade or tint than the color next to it, that is found on both laced and solid feathers. When it occurs on laced feathers, as in edging of white around the outside of black lacing, it is the same as double lacing. Fig. 10.

Surface Color.—The color on the parts of the feathers exposed to view.

Sword Feather.—A main tail feather of a Japanese Bantam male.

Symmetry.—The blending of all sections or parts of a fowl into a harmonious whole.

Tail Coverts.—The curved, soft feathers about the sides of the lower part of the tail feathers. See 30, Fig. 1.

Tail Feathers.—The stiff, or main, feathers of the tail. See 31, Fig. 1.

Team.—Three or more fowls shown by one exhibitor.

Thigh.—The upper segment of the leg; it is included between the body of the fowl and the upper extremity of what is known as the drumstick.

Thoroughbred.—(1) Of the best or the purest breeding; in this sense, now generally replaced by the term standard bred. (2) A term descriptive of game cocks of high courage and spirits.

Throat.—Same as gullet.

Thumb Mark.—(1) A hollow place in the side of a single comb. Fig. 24. (2) An opening or split in the front or center of a rose comb.

Ticked.—Plumage is ticked when it has spots of color different from the rest of the plumage.



FIG. 31

Tight Feathered.—Fowls are said to be tight feathered when the feathers lie close to the body; close feathered.

Tom.—A male turkey; a gobbler.

Top Color.—The color of the plumage on the back.

Topknot.—A tufted growth of feathers on the top of the head of a fowl; a crest. Figs. 9 and 16.

Training.—The teaching or drilling of a fowl to pose in the show room.

Tricolored.—Of three colors.

Trimming.—A fraudulent way of preparing a fowl for the show room. See faking.

Trio.—Three; in poultry, a male and two females.

Trunk.—The body of a fowl, as distinguished from its appendages, the legs, neck, head, etc.

Tucked Up.—A fowl is said to be tucked up when the abdomen lacks fulness and makes a sharp upward turn to the tail, as in game fowls.

Twisted Comb.—A comb twisted into curves or some other faulty shape. Fig. 32.



FIG. 32

Type.—The form peculiar to any breed.

Under Plumage.—The fluff or under part of the plumage, seen only when the feathers are separated. See feather, and *b*, Fig. 12.

Utility Fowl.—A fowl for egg production and market purposes, as distinguished from an exhibition fowl.

Variety.—A subdivision of a breed; distinguished from other varieties of the same breed by the plumage colors. See breed.

V-Shaped Comb.—A comb having two points or prongs; also called antler comb, and horn comb. Fig. 2.

Vulture Hock.—A hock like that of a vulture, which has stiff feathers growing from the hock joint. See *16*, Fig. 1.

Washiness.—A state or quality of a feather that appears to have had the color washed out of it.

Waster.—A fowl unfit for breeding purposes, but fit for food.

Wattles.—Pendant growths of flesh that hang on each side of the beak; most prominently developed in male fowls.

Web.—(1) The upper part of a feather where the barbs are stuck together; the flat, thin feather structure beyond the fluff part of the feather. See feather and *a*, Fig. 12. (2) The skin growing between the toes. (3) The skin between the joints of the wing.

Web Foot.—A foot with webs between the toes. When a fowl other than a water fowl has a foot with webs between the toes, it is said to have a web foot.

Wheaten.—An uneven brown like that on ripe standing wheat; peculiar to some females of the Black-Breasted Red Games and the Faverolles.

Whip Tail.—The fine, slim tail of the modern game or game bantam fowl.

Whiskers.—Feathers growing from the side of the face; same as muff. Sometimes applied to the muffling below the beak. See 6, Fig. 1.

Whole Color.—A fowl is said to be of a whole color when all of its plumage is of one color, as buff or black, but this does not mean that all the plumage must be of one shade of the color.

Willow Color.—A greenish yellow color peculiar to the shanks of some game fowls.

Wing Bar.—A bar of dark color across the middle of a wing. See 35, Fig. 1.

Wing Bay.—A triangular surface showing on the wing where it is folded; located between the wing bar and the point of the wing. See 36, Fig. 1.

Wing Bow.—The surface of the wing between the wing bar and the shoulder. See 33, Fig. 1.

Wing Butts.—The ends of the flight feathers; a misnomer for wing points.

Wing Coverts.—The feathers that cover the roots of the secondary flight feathers.



FIG. 33

Wing Fronts.—The fronts of the wings, properly called shoulders; improperly called wing butts.

Wing Points.—The extreme outer ends of the flight feathers.

Work, Full of Work.—A term used in England to describe a well-finished rose comb, the points of which are perfect or nearly perfect.

Wry Tail.—A tail carried to one side. Fig. 33.

ARITHMETIC

MEASURES OF EXTENSION

Measures of extension are used in measuring lengths (distances), surfaces (areas), and solids (volumes), and are divided, accordingly, into linear measure, square measure, and cubic measure.

Linear measure has one dimension (length), square measure has two dimensions (length and breadth), and cubic measure has three dimensions (length, breadth, and thickness).

LINEAR MEASURE

12 inches (in.) = 1 foot.....	ft.
3 feet.....	= 1 yard.....	yd.
5½ yards.....	= 1 rod.....	rd.
320 rods.....	= 1 mile.....	mi.

in. ft. yd. rd. mi.

12 = 1

36 = 3 = 1

198 = 16½ = 5½ = 1

63,360 = 5,280 = 1,760 = 320 = 1

SQUARE MEASURE

144 square inches (sq. in.) = 1 square foot.....	sq. ft.
9 square feet.....	= 1 square yard.....	sq. yd.
30½ square yards.....	= 1 square rod.....	sq. rd.
160 square rods.....	= 1 acre.....	A.
640 acres.....	= 1 square mile.....	sq. mi.

<i>sq. in.</i>	<i>sq. ft.</i>	<i>sq. yd.</i>	<i>sq. rd.</i>	<i>A.</i>	<i>sq. mi.</i>
144 =	1				
1,296 =	9 =	1			
39,204 =	272½ =	30½ =	1'		
6,272,640 =	43,560 =	4,840 =	160 =	1	
4,014,489,600 =	27,878,400 =	3,097,600 =	102,400 =	640 =	1

SURVEYORS' SQUARE MEASURE

625 square links (sq. li.)	= 1 square rod	sq. rd.
16 square rods	= 1 square chain	sq. ch.
10 square chains	= 1 acre	A.
640 acres	= 1 square mile	sq. mi.
36 square miles (6 miles square)	= 1 township	Tp.

A square measuring 208.71 ft. on each side contains 1 A.

The following are the comparative sizes, in square yards, of acres in different places:

	<i>sq. yd.</i>		<i>sq. yd.</i>
England and America	4,840	Amsterdam	9,722
Scotland	6,150	Dantzic	6,650
Ireland	7,840	France	11,960
Hamburg	11,545	Prussia	3,053

CUBIC MEASURE

1,728 cubic inches (cu. in)	= 1 cubic foot	cu. ft.
27 cubic feet	= 1 cubic yard	cu. yd.
128 cubic feet	= 1 cord of wood.	

<i>cu. in.</i>	<i>cu. ft.</i>	<i>cu. yd.</i>
1,728 =	1	
46,656 =	27 =	1

MEASURES OF WEIGHT

AVOIRDUPOIS WEIGHT

16 ounces (oz.)	= 1 pound	lb.
100 pounds	= 1 hundredweight	cwt.
20 hundredweight } 2,000 pounds	= 1 ton	T.

<i>oz.</i>	<i>lb.</i>	<i>cwt.</i>	<i>T.</i>
16 =	1		
1,600 =	100 =	1	
32,000 =	2,000 =	20 =	1

LONG-TON TABLE

16 ounces (oz.)	= 1 pound	lb.
28 pounds	= 1 quarter	qr.
4 quarters	= 1 hundredweight	cwt.
20 hundredweight } 2,240 pounds	= 1 ton	T.

oz.	lb.	qr.	cwt.	T.
16 =	1			
448 =	28 =	1		
1,792 =	112 =	4 =	1	
35,840 =	2,240 =	80 =	20 =	1

TROY WEIGHT

24 grains (gr.)	= 1 pennyweight	pwt.
20 pennyweights	= 1 ounce	oz.
12 ounces	= 1 pound	lb.

gr.	pwt.	oz.	lb.
24 =	1		
480 =	20 =	1	
5,760 =	240 =	12 =	1

APOTHECARIES' WEIGHT

20 grains (gr.)	= 1 scruple	sc. or ℥
3 scruples	= 1 dram	dr. or ℥
8 drams	= 1 ounce	oz. or ℥
12 ounces	= 1 pound	lb. or lb.

gr.	℥	℥	℥	lb
20 =	1			
60 =	3 =	1		
480 =	24 =	8 =	1	
5,760 =	288 =	96 =	12 =	1

MEASURES OF CAPACITY

LIQUID MEASURE

4 gills (gi.)	= 1 pint	pt.
2 pints	= 1 quart	qt.
4 quarts	= 1 gallon	gal.
31½ gallons	= 1 barrel	ddl.
2 barrels } 63 gallons }	= 1 hogshead	hhd.

gi. pt. qt. gal. bbl. hhd.

$$4 = 1$$

$$8 = 2 = 1$$

$$32 = 8 = 4 = 1$$

$$1,008 = 252 = 126 = 31\frac{1}{2} = 1$$

$$2,016 = 504 = 252 = 63 = 2 = 1$$

APOTHECARIES' FLUID MEASURE

60 minims, or drops (\mathfrak{m})	= 1 fluid dram	f $\bar{3}$
8 fluid drams	= 1 fluid ounce	f $\bar{3}$
16 fluid ounces	= 1 pint	O.
8 pints	= 1 gallon	Cong.

DRY MEASURE

2 pints (pt.)	= 1 quart	qt.
8 quarts	= 1 peck	pk.
4 pecks	= 1 bushel	bu.

pt. qt. pk. bu.

$$2 = 1$$

$$16 = 8 = 1$$

$$64 = 32 = 4 = 1$$

AVOIRDUPOIS POUNDS IN A BUSHEL

Commodities	Lb.	Commodities	Lb.
Barley	48	Malt	34
Beans	60	Oats	32
Buckwheat	48	Potatoes	60
Clover seed	60	Rye	56
Corn (shelled)	56	Timothy seed	45
Corn (in the ear)	70	Wheat	60

The following units are also in commercial use:

1 quintal of fish = 100 lb.

1 barrel of flour = 196 lb.

1 barrel of pork or beef = 200 lb.

1 gallon of petroleum = 6 $\frac{1}{2}$ lb.

1 keg of nails = 100 lb.

MEASURES OF TIME

60 seconds (sec.).....	= 1 minute.....	min.
60 minutes.....	= 1 hour.....	hr.
24 hours.....	= 1 day.....	da.
7 days.....	= 1 week.....	wk.
4 weeks.....	= 1 month.....	mo.
12 months.....	= 1 year.....	yr.
100 years.....	= 1 century.....	C.

	<i>sec.</i>	<i>min.</i>	<i>hr.</i>	<i>da</i>	<i>wk.</i>	<i>yr.</i>
	60 =	1				
	3,600 =	60 =	1			
	86,400 =	1,440 =	24 =	1		
	604,800 =	10,080 =	168 =	7 =	1	
	31,556,936 =	525,948 =	8,765 =	365 =	52 =	1

The following is a list of the months, in regular order, with the number of days each contains:

	<i>Days</i>		<i>Days</i>
1. January (Jan.).....	31	7. July	31
2. February (Feb)	28	8. August (Aug.)	31
3. March (Mar.)	31	9. September (Sept.)..	30
4. April (Apr.)	30	10. October (Oct.)	31
5. May	31	11. November (Nov.) ..	30
6. June	30	12. December (Dec.) ...	31

In leap years, 1 da. is added to Feb., giving it 29 da. The following lines will assist in remembering the number of days in each month:

“Thirty days have September,
 April, June, and November;
 All the rest have thirty-one,
 Except the second month alone,
 To which we twenty-eight assign,
 ’Till leap year gives it twenty-nine.”

In many business transactions, the year is regarded as 360 da., or 12 mo. of 30 da. each.

MEASURES OF ANGLES OR ARCS

CIRCULAR MEASURE

60 seconds (") = 1 minute.....	'
60 minutes.....	= 1 degree.....	°
360 degrees.....	= 1 circle.....	⊙

$$60'' = 1'$$

$$3,600'' = 60' = 1^\circ$$

$$1,296,000'' = 21,600' = 360^\circ = 1\odot$$

A *quadrant* is one-fourth of a circle, or 90° ; a *sextant* is one-sixth of a circle, or 60° . A right angle (\perp) contains 90° . The unit of measurement is the degree, or $\frac{1}{360}$ of the circumference of a circle.

Circular, or angular, measure is used principally by surveyors, navigators, astronomers, and by technical men generally, for measuring angles and arcs of circles.

METRIC SYSTEM OF MEASURES

The metric system is based on the meter, which, according to the U. S. Coast and Geodetic Survey Report of 1884, is equal to 39.370432 in. The value commonly used is 39.37 in. and is authorized by the U. S. government.

There are three principal units—the *meter*, the *liter* (pronounced 'lee-ter'), and the *gram*, the units of length, capacity, and weight, respectively. Multiples of these units are obtained by prefixing to the names of the principal units the Greek words *deca* (10), *hecto* (100), and *kilo* (1,000); the submultiples, or divisions, are obtained by prefixing the Latin words *deci* ($\frac{1}{10}$), *centi* ($\frac{1}{100}$), and *mili* ($\frac{1}{1000}$). These prefixes form the key to the entire system. The abbreviations of the principal units of these submultiples begin with a small letter, while those of the multiples begin with a capital letter.

MEASURES OF LENGTH

10 millimeters (mm.)	= 1 centimeter	cm.
10 centimeters	= 1 decimeter	dm.
10 decimeters	= 1 meter	m.
10 meters	= 1 decameter	Dm.
10 decameters	= 1 hectometer	Hm.
10 hectometers	= 1 kilometer	Km.

MEASURES OF SURFACE (NOT LAND)

100 square millimeters (sq. mm.)	= 1 square centimeter	sq. cm.
100 square centimeters	= 1 square decimeter	sq. dm.
100 square decimeters	= 1 square meter	sq. m.

MEASURES OF VOLUME

1,000 cubic millimeters (cu. mm.)	= 1 cubic centimeter	cu. cm.
1,000 cubic centimeters	= 1 cubic decimeter	cu. dm.
1,000 cubic decimeters	= 1 cubic meter	cu. m.

MEASURES OF CAPACITY

10 millimeters (ml.)	= 1 centileter	cl.
10 centileters	= 1 decileter	dl.
10 decileters	= 1 liter	l.
10 liters	= 1 decaliter	Dl.
10 decaliters	= 1 hectoliter	Hl.
10 hectoliters	= 1 kiloliter	Kl.

The liter is equal to the volume occupied by 1 cu. dm.

MEASURES OF WEIGHT

10 milligrams (mg.)	= 1 centigram	cg.
10 centigrams	= 1 decigram	dg.
10 decigrams	= 1 gram	g.
10 grams	= 1 decagram	Dg.
10 decagrams	= 1 hectogram	Hg.
10 hectograms	= 1 kilogram	Kg.
1,000 kilograms	= 1 ton	T.

The gram is the weight of 1 cu. cm. of pure distilled water at a temperature of 39.2° F.; the kilogram is the weight of 1 liter of water; the ton is the weight of 1 cu. m. of water.

MEASURES OF MONEY

UNITED STATES MONEY

10 mills (m.)	= 1 cent	c.
10 cents	= 1 dime	d.
10 dimes	= 1 dollar	\$
10 dollars	= 1 eagle	E.

<i>m.</i>	<i>ct.</i>	<i>d.</i>	<i>\$</i>	<i>E.</i>
10 =	1			
100 =	10 =	1		
1,000 =	100 =	10 =	1	
10,000 =	1,000 =	100 =	10 =	1

The term *legal tender* is applied to money that may be legally offered in payment of debts. All gold coins are legal tender for their face value to any amount, provided their weight has not diminished more than $\frac{1}{100}$. Silver dollars are also legal tender to any amount; but silver coins of lower denominations than \$1 are legal tender only for sums not exceeding \$10. Nickel and copper coins are legal tender for sums not exceeding 25c.

The legal coins of the United States are:

	GOLD COINS	Weight in Grains
1-dollar piece		= 25.8
2½-dollar piece, or quarter eagle		= 64.5
3-dollar piece		= 77.4
5-dollar piece, or half eagle		= 129.0
10-dollar piece, or eagle		= 258.0
20-dollar piece, or double eagle		= 516.0

	SILVER COINS	Weight
Standard dollar		= 412.5 grains
Half dollar, or 50-cent piece		= 192.9 grains, or 12½ grams
Quarter dollar, or 25-cent piece		= 96.45 grains, or 6¼ grams
Dime, or 10-cent piece		= 38.58 grains, or 2½ grams

	COPPER AND NICKEL COINS	Weight
5-cent piece		= 77.16 grains, or 5 grams
3-cent piece		= 30.00 grains
1-cent piece		= 48.00 grains

ENGLISH MONEY

4 farthings (far.)	= 1 penny	d.
12 pence	= 1 shilling	s.
20 shillings	= 1 pound, or sovereign	£

far.	d.	s.	£
4	=	1	
48	=	12	= 1
960	=	240	= 20 = 1

The unit of English money is the *pound sterling*, the value of which in United States money is \$4.8665. The fineness of English silver is .925; of the gold coins, .916 $\frac{2}{3}$. What is called sterling silver when applied to solid-silver articles has the same fineness. Hence the name *sterling silver*.

The other coins of Great Britain are the *florin* (= 2 shillings), the *crown* (= 5 shillings), the *half crown* (= 2 $\frac{1}{2}$ shillings), and the *guinea* (= 21 shillings). The largest silver coin is the crown, and the smallest the threepence ($\frac{1}{4}$ shilling). The shilling is worth 25c. (24.3+c.) in United States money. The guinea is no longer coined. The abbreviation £ is written before the number, while s. and d. follow. Thus, £25 4s. 6d. = 25 pounds 4 shillings 6 pence.

Rule.—To reduce pounds, shillings, and pence to dollars and cents, reduce the pounds to shillings, add the shillings, if any, and multiply the sum by 24 $\frac{1}{4}$; if any pence are given, increase this product by twice as many cents as there are pence.

EXAMPLE.—Reduce £4 7s. 11d. to dollars and cents.

SOLUTION.— $(4 \times 20 + 7) \times 24\frac{1}{4} + 2 \times 11 = \21.39 .

Rule.—To reduce pounds to dollars, and vice versa, exchange being at \$4.8665: Multiply the number of pounds by 73, and divide the quotient by 15; the result will be the equivalent in dollars and cents. Or, multiplying the dollars by 15 and dividing the product by 73 will give its equivalent in pounds and decimals of a pound.

EXAMPLE 1.—Reduce £6 to dollars and cents.

SOLUTION.— $6 \times 73 \div 15 = \$29.20$.

EXAMPLE 2.—Reduce \$17 to pounds.

SOLUTION.— $17 \times 15 \div 73 = £3.493$.

The monetary units of leading foreign nations and their equivalents in United States money are as follows. These rates are proclaimed each year by the Secretary of the Treasury.

Country	Monetary Unit	Value in U. S. Gold
Canada.....	Dollar = 100 cents.....	\$1.00
Great Britain....	Pound = 20 shillings.....	4.86 $\frac{1}{2}$
France.....	Franc = 100 centimes.....	.193
Belgium....		
Switzerland }		
Italy.....	Lira = 100 centesimi193
Spain.....	Peseta = 100 centimos.....	.193
German Empire..	Mark = 100 pfennigs238
Denmark }	Crown = 100 öre.....	.268
Norway }		
Sweden }		
Russia.....	Ruble = 100 copecks.....	.515
Japan.....	Yen = 100 sen.....	.498

HEAT

SPECIFIC HEATS OF METALS

The specific heat of a substance is the number of heat units required to raise a unit mass of the substance one degree in temperature. The specific heat of water is very nearly constant for all temperatures, but that at its temperature of maximum density (4° C. or 39.1° F.) is considered unity. The specific heats of most substances increase with increasing temperatures.

HEAT UNITS

One *British thermal unit* (B. T. U.) is the quantity of heat required to raise the temperature of 1 lb. of pure water 1° F. at or near its maximum density, 39.1° F.

One *calorie* is the quantity of heat required to raise the temperature of 1 Kg. of water 1° C. at or near 4° C.

1 B. T. U. = .252 calorie and 1 calorie = 3.968 B. T. U.

One *small*, or *gram*, *calorie* (a heat unit also in some use) is the quantity of heat required to raise the temperature of 1 gram of water 1° C. at or near 4° C.

CENTIGRADE AND FAHRENHEIT DEGREES

Deg. C.	Deg. F.	Deg. C.	Deg. F.	Deg. C.	Deg. F.	Deg. C.	Deg. F.
0	32.0	26	78.8	51	123.8	76	168.8
1	33.8	27	80.6	52	125.6	77	170.6
2	35.6	28	82.4	53	127.4	78	172.4
3	37.4	29	84.2	54	129.2	79	174.2
4	39.2	30	86.0	55	131.0	80	176.0
5	41.0	31	87.8	56	132.8	81	177.8
6	42.8	32	89.6	57	134.6	82	179.6
7	44.6	33	91.4	58	136.4	83	181.4
8	46.4	34	93.2	59	138.2	84	183.2
9	48.2	35	95.0	60	140.0	85	185.0
10	50.0	36	96.8	61	141.8	86	186.8
11	51.8	37	98.6	62	143.6	87	188.6
12	53.6	38	100.4	63	145.4	88	190.4
13	55.4	39	102.2	64	147.2	89	192.2
14	57.2	40	104.0	65	149.0	90	194.0
15	59.0	41	105.8	66	150.8	91	195.8
16	60.8	42	107.6	67	152.6	92	197.6
17	62.6	43	109.4	68	154.4	93	199.4
18	64.4	44	111.2	69	156.2	94	201.2
19	66.2	45	113.0	70	158.0	95	203.0
20	68.0	46	114.8	71	159.8	96	204.8
21	69.8	47	116.6	72	161.6	97	206.6
22	71.6	48	118.4	73	163.4	98	208.4
23	73.4	49	120.2	74	165.2	99	210.2
24	75.2	50	122.0	75	167.0	100	212.0
25	77.0						

TEMPERATURE

The temperature of a body is its degree of sensible heat. For the measurement of temperatures there are three kinds of thermometers: the Fahrenheit, abbreviated F. or Fahr., commonly used in America; the Centigrade, abbreviated C. or Cent., used in France and by scientists everywhere; and the Réaumur, abbreviated R. or Réau., used in Germany.

<i>Standard Points</i>	<i>Degrees F.</i>	<i>Degrees C.</i>	<i>Degrees R.</i>
Boiling point of water at sea level; i. e., pressure = 1 atmosphere.....	212	100	80
Melting point of ice.....	32	0	0
Absolute zero, i. e., the total absence of heat; theoretical only.....	-460	-273	-219

Between boiling point and freezing point = 180° F. = 100° C.
= 80° R.

$$\text{Temp. F.} = \frac{9}{5} \text{Temp. C.} + 32^{\circ} = \frac{9}{4} \text{Temp. R.} + 32^{\circ}.$$

$$\text{Temp. C.} = \frac{5}{9} (\text{Temp. F.} - 32^{\circ}) = \frac{5}{4} \text{Temp. R.}$$

$$\text{Temp. R.} = \frac{4}{9} (\text{Temp. F.} - 32^{\circ}) = \frac{4}{5} \text{Temp. C.}$$

MISCELLANEOUS TABLES

The following table is used in counting certain articles:

12 of anything.....	= 1 dozen.....	doz.
12 dozen.....	= 1 gross.....	gr.
12 gross.....	= 1 great gross.....	g. gr.
20 of anything.....	= 1 score	

units doz. gr. g. gr.

$$12 = 1$$

$$144 = 12 = 1$$

$$1,728 = 144 = 12 = 1$$

The following table is used in the paper trade:

24 sheets.....	= 1 quire.....	qr.
20 quires.....	= 1 ream.....	rm.
2 reams.....	= 1 bundle.....	bdl.
5 bundles.....	= 1 bale.....	B.

sheets *qr.* *rm.* *bdl.* *B.*

$$24 = 1$$

$$480 = 20 = 1$$

$$960 = 40 = 2 = 1$$

$$4,800 = 200 = 10 = 5 = 1$$

It is now becoming customary to consider 500 sheets as a ream, and to discard the higher denominations.

BOOKS

The terms folio, quarto, octavo, etc., show the number of leaves into which a sheet of paper is folded.

Folio	= 2 leaves, or 4 pages
Quarto	= 4 leaves, or 8 pages
Octavo	= 8 leaves, or 16 pages
Duodecimo	= 12 leaves, or 24 pages
16mo	= 16 leaves, or 32 pages
18mo	= 18 leaves, or 36 pages
24mo	= 24 leaves, or 48 pages
32mo	= 32 leaves, or 64 pages

METRIC EQUIVALENTS OF POUNDS, FEET, ETC.

The government publishes the equivalents in pounds, etc., of the metric system, but the American shipper wants to know what the pounds, inches, feet, and gallons, to which he is accustomed, are in the metric system. The following is a convenient table showing the metric values of our measures. Some countries demand that the metric system should be used in the consular papers, and in most countries, especially in Latin-America, the consignees ask for the weights, etc., in the metric system. This table will be found valuable for reference by invoice clerks and shipping clerks in the export departments of manufacturing establishments.

<i>Pounds</i>	<i>Kilos</i>	<i>Pounds</i>	<i>Kilos</i>
1	= .4536	60.....	= 27.216
2.....	= .9072	70.....	= 31.751
3.....	= 1.3608	80.....	= 36.287
4.....	= 1.8144	90.....	= 40.823
5.....	= 2.2680	100.....	= 45.36
6.....	= 2.7216	200.....	= 90.72
7.....	= 3.1751	300.....	= 136.08
8.....	= 3.6287	400.....	= 181.44
9.....	= 4.0823	500.....	= 226.80
10.....	= 4.536	600.....	= 272.16
20.....	= 9.072	700.....	= 317.51
30.....	= 13.608	800.....	= 362.87
40.....	= 18.144	900.....	= 408.23
50.....	= 22.680	1,000.....	= 453.60

1,000 kilos = 1 metric ton (Tonelada metrico).

<i>Centimeters</i>	<i>Centimeters</i>		
1 inch.....	= 2.54	7 feet.....	= 213.36
1 foot.....	= 30.48	8 feet.....	= 243.84
1 yard.....	= 91.44	9 feet.....	= 274.32
2 feet.....	= 60.96	10 feet.....	= 304.80
3 feet.....	= 91.44	11 feet.....	= 335.28
4 feet.....	= 121.92	12 feet.....	= 365.76
5 feet.....	= 152.40	13 feet.....	= 396.24
6 feet.....	= 182.88	14 feet.....	= 426.72

DIFFERENCE OF SUN TIME BETWEEN NEW YORK CITY AND OTHER PARTS OF THE WORLD

When it is noon at New York, it is, at

Buffalo.....	11:40 A. M.	Boston.....	12:12 P. M.
Cincinnati.....	11:18 A. M.	Quebec.....	12:12 P. M.
Chicago.....	11:07 A. M.	London.....	4:55 P. M.
St. Louis.....	10:55 A. M.	Paris.....	5:05 P. M.
San Francisco.....	8:45 A. M.	Rome.....	5:45 P. M.
New Orleans.....	10:56 A. M.	Constantinople...	6:41 P. M.
Washington.....	11:48 A. M.	Vienna.....	6:00 P. M.
Charleston.....	11:36 A. M.	St. Petersburg....	6:57 P. M.
Havana.....	11:25 A. M.	Peking.....	12:40 A. M.

TABLE OF DISTANCES

1 mile.....	= 5,280 ft.; 1,760 yd.; 320 rd.; 8 fur.
1 furlong.....	= 40 rd.
1 league.....	= 3 mi.
1 knot,* or nautical mile.....	= 6,080 ft., or $1\frac{1}{2}$ mi.
1 nautical league.....	= 3 naut. mi.
1 fathom.....	= 6 ft.
1 meter.....	= 3 ft. $3\frac{1}{8}$ in., nearly
1 hand.....	= 4 in.
1 palm.....	= 3 in.
1 span.....	= 9 in.
1 cable's length.....	= 240 yd.

MEASURES OF VOLUME

1 cubic foot.....	= 1,728 cu. in.
1 ale gallon.....	= 282 cu. in.
1 standard, or wine, gallon.....	= 231 cu. in.
1 dry gallon.....	= 268.8 cu. in.
1 bushel.....	= 2,150.4 cu. in.
1 British bushel.....	= 2,218.19 cu. in.
1 cord of wood.....	= 128 cu. ft.
1 perch.....	= 24.75 cu. ft.
1 ton of round timber.....	= 40 cu. ft.
1 ton of hewn timber.....	= 50 cu. ft.

A box $12\frac{1}{8}$ in. long, wide, and deep contains 1 bu.

A box $19\frac{3}{8}$ in. long, wide, and deep contains 1 bbl.

A box $8\frac{1}{2}$ in. long, wide, and deep contains 1 pk.

A box $6\frac{7}{16}$ in. long, wide, and deep contains $\frac{1}{2}$ pk.

A box $4\frac{1}{16}$ in. long, wide, and deep contains 1 qt.

Cylinders having the following dimensions, in inches, contain the measures stated, very closely; the diameters are given first:

Gill.....	= $1\frac{3}{4}$ in. \times 3 in.	Gallon.....	= 7 in. \times 6 in.
Pint.....	= $3\frac{1}{2}$ in. \times 3 in.	8 gallons.....	= 14 in. \times 12 in.
Quart.....	= $3\frac{1}{2}$ in. \times 6 in.	10 gallons....	= 14 in. \times 15 in.

*A knot is really a measure of speed and not of distance; when used in this sense, it is equivalent to 1 naut. mi. in 1 hr. Thus, a vessel traveling 20 naut. mi. per hr. has a speed of 20 knots.

PLASTERING, PAINTING, AND CALCIMINING

Plastering, painting, and calcimining are usually estimated by the square yard. Allowances for doors, windows, etc. are not regulated by any established usage.

Rule.—Multiply the *perimeter** of the room by the height of the ceiling for the area of the walls. To this add the area of the ceiling, and from the sum make such deductions as are specified. Reduce the results to square yards, and multiply the price per square yard by the number denoting the area in square yards.

EXAMPLE.—At 22c. per sq. yd., what will it cost to plaster a room 65 ft. long, 22 ft. wide, and 15 ft. high, deducting in full for 8 doors 4 ft. 6 in. wide and 11 ft. 6 in. high, 10 windows 3 ft. 6 in. wide and 8 ft. high, and a baseboard $6\frac{1}{2}$ in. high extending around the room?

SOLUTION.—

Perimeter of the room.....	$= 65 \times 2 + 22 \times 2 = 174$	ft.
Area of walls.....	$= 174 \times 15 = 2610$	sq. ft.
Area of ceiling.....	$= 65 \times 22 = 1430$	sq. ft.
Total.....	$= 4040$	sq. ft.
Area of doors.....	$= 4\frac{1}{2} \times 11\frac{1}{2} \times 8 = 414$	sq. ft.
Area of windows.....	$= 3\frac{1}{2} \times 8 \times 10 = 280$	sq. ft.
Area of baseboard.....	= (perimeter less	
width of 8 doors) $\times \frac{6\frac{1}{2}}{12} = (174 - 4\frac{1}{2} \times 8) \times \frac{6\frac{1}{2}}{12} =$	$74\frac{1}{2}$	sq. ft.
Total, after deduction.....	$= 3271\frac{1}{2}$	sq. ft.
Area in square yards.....	$= 3271\frac{1}{2} \div 9 = 363\frac{1}{2}$	sq. yd.
Cost.....	$= \$.22 \times 363\frac{1}{2} = \79.96	

PAPERING

Wallpaper as made in the United States, is 18 in. ($\frac{1}{2}$ yd.) wide, and is sold in single rolls and double rolls; a single roll is 8 yd. long, and a double roll is 16 yd. long. When cutting the paper, paper hangers divide the rolls into strips of sufficient length to reach

*The perimeter is the sum of the lengths of the sides of the room.

from the baseboard to a short distance (say 6 in.) above the lower edge of the border. There is always considerable waste in cutting, owing to the matching of the figures forming the design, and the fact that there is a part of a strip left over after cutting up the roll. The parts of strips thus left over are used for the surface above doors and below windows, and other irregular places. Although double rolls are usually counted as 2 single rolls, there is a choice between them in certain cases. Thus, suppose the strips were required to be 9 ft. (3 yd.) long, only 2 strips could be cut from a single roll, or 4 strips from 2 single rolls, while 5 strips could be cut from a double roll. The length of a roll of border is the same as the length of a roll of paper.

On account of the waste in cutting, the various sizes and shapes of rooms, the number of windows, doors, etc., it is difficult to estimate exactly the number of rolls required. Two rules are given, both of which are used in practice:

Rule.—I. *From the perimeter of the room, subtract the widths of openings (windows and doors), and reduce the result to half yards; the number of half yards so obtained will be the total number of strips required. Find the number of strips that can be cut from a roll, and divide the first result by the second; the quotient will be the number of rolls required.*

II. *Divide the number of half yards of the perimeter of the room by the number of strips that can be cut from a roll; the quotient will be the number of rolls required.*

If computed by the first rule, the number of rolls obtained may be too small, and if computed by the second rule, too large. But, since paper dealers will usually take back all rolls that are intact, the second rule will generally give the best results, as it will prevent the loss of time required to send to the dealer for extra rolls, in case they are needed.

EXAMPLE.—Find how much paper will be needed to cover the walls and ceiling of a room 15 ft. \times 20 ft., the border for both walls and ceiling to be 18 in. wide. The

baseboard is 8 in. high, and the height of walls from floor to ceiling is 9 ft.

SOLUTION.—Since the widths of the openings are not specified, it will be necessary to use rule II.

Perimeter of room = $2 \times 15 + 2 \times 20 = 70$ ft. = $23\frac{1}{3}$ yd. = $46\frac{2}{3}$ half yards, or 47 strips. Assuming that the strips extend the height of the baseboard above the bottom edge of the border, the length of a strip is (since 18 in. = $1\frac{1}{2}$ ft.) $9 - 1\frac{1}{2} = 7\frac{1}{2}$ ft. = $2\frac{1}{2}$ yd. Hence, the number of strips in a single roll is $8 \div 2\frac{1}{2} = 3$ strips, and the number of rolls required is $47 \div 3 = 15\frac{2}{3}$, or 16 rolls.

In papering the ceiling, the direction in which the strips are to run must be considered. If the strips run lengthwise of the room, the distance between the edges of the border is $20 - 2 \times 1\frac{1}{2} = 17$ ft., and the length of the strips must be at least 18 ft., or 6 yd., long; hence, but 1 strip can be cut from a single roll, and but 2 strips from a double roll. The width of the room in half yards is $(15 \div 3) \times 2 = 10$; hence, allowing for the border, 9 strips, or 9 single rolls, will be required.

If the strips run crosswise of the room, the length of a strip between the edges of the border will be $15 - 2 \times 1\frac{1}{2} = 12$ ft., and the length of a strip must be at least 13 ft., or $4\frac{1}{3}$ yd.; hence, 1 strip may be obtained from a single roll, or $16 \div 4\frac{1}{3} = 3$ strips from a double roll. The length of the room in half yards is $(20 \div 3) \times 2 = 13\frac{1}{3}$; hence, allowing the paper to extend 6 in. beyond the inner edge of the border, at both ends of the room, 12 strips will be required. The number of double rolls required will be $12 \div 3 = 4$ double rolls. Consequently, in this case, there is less waste when the paper runs crosswise than when it runs lengthwise.

Since the perimeter of the room is 70 ft., or $23\frac{1}{3}$ yd., $23\frac{1}{3} \div 8 = 3$ single rolls of border for the walls, and the same amount for the ceiling will be required. Therefore, 16 single rolls of paper are required for the walls, 4 double rolls for the ceiling, 3 single rolls of border for the walls, and 3 single rolls for the ceiling.

CARPETING

Carpet is made in various widths. Ingrain carpet is usually 36 in., or 1 yd., wide; Brussels carpet is 27 in., or $\frac{3}{4}$ yd., wide. Carpet borders are $22\frac{1}{2}$ in., or $\frac{5}{8}$ yd., wide. A linear yard of ingrain carpet contains 1 sq. yd., and a linear yard of Brussels carpet contains $\frac{3}{4}$ sq. yd.

Rule.—To find the number of linear yards of carpet required for a room, if no allowance is made for cutting and matching the strips, divide the area of the room in square yards by the area of a linear yard of the carpet.

EXAMPLE.—How many yards of Brussels carpet will be required to cover a floor 36 ft. long and 21 ft. wide, making no allowance for cutting and matching?

SOLUTION.—Area of floor = $36 \times 21 = 756$ sq. ft. = $\frac{756}{9}$
 = 84 sq. yd. A linear yard of Brussels carpet has an area of $\frac{3}{4}$ sq. yd. Hence, the number of linear yards required is $84 \div \frac{3}{4} = 112$ yd.

In practice, there is usually considerable loss due to cutting and matching. To find the number of yards required for a room, when allowance is made for loss, the width of the room is divided by the width of a single strip. The quotient is the number of strips required, supposing them to run lengthwise of the room. The number of strips multiplied by the length in yards of a single strip, making allowance for the loss required for matching, is the number of linear yards required.

EXAMPLE.—How many yards of Brussels carpet will be required to cover a room 23 ft. long and 15 ft. wide, making an allowance of 1 ft. on each strip for matching? The carpet is supposed to run lengthwise.

SOLUTION.—Width of room = 15 ft. = 180 in. Width of carpet = 27 in. Number of strips = $180 \div 27 = 6\frac{2}{3}$. Hence, 7 strips must be used, the excess, 9 in., being cut off or turned under. Allowing 1 ft. for matching, length of strip = $23 + 1 = 24$ ft. = 8 yd. Number of linear yards required = $7 \times 8 = 56$ yd.

The number of linear yards of carpet border required for a room is equal to the perimeter of the room in yards.

EXAMPLE.—How many yards of border will be required in carpeting a room 42 ft. long and $26\frac{1}{2}$ ft. wide?

SOLUTION.—Perimeter of room = $42 \times 2 + 26\frac{1}{2} \times 2 = 137$ ft.
 $= \frac{137}{3} = 45\frac{2}{3}$ yd.

BOARD MEASURE

In measuring lumber, the unit is the *board foot*, which is a board 1 ft. long, 1 ft. wide, and 1 in. (or less) thick. One board foot is equal to $\frac{1}{12}$ cu. ft.

Rule.—To find the number of board feet in any piece of lumber, multiply the length in feet by the breadth in feet, and this product by the thickness in inches, if it be more than 1 inch; or, otherwise, multiply the length in feet by the breadth in inches, and this product by the thickness in inches, and then divide by 12.

EXAMPLE.—How many board feet are contained in a joist 18 ft. long, 14 in. wide, and 12 in. thick?

SOLUTION.— $\frac{18 \times 14 \times 12}{12} = 252$ board feet.

Lumber is sold by the thousand (M) feet, the term foot being always used instead of the longer term, board foot.

Rule.—To find the cost of lumber, divide the number of feet by 1,000 and multiply by the cost per M.

EXAMPLE.—What will be the cost of 19 boards 14 ft. long, 15 in. wide, and $1\frac{1}{2}$ in. thick, at \$23.50 per M?

SOLUTION.—Number of thousand feet = $\frac{19 \times 14 \times 15 \times 1\frac{1}{2}}{12 \times 1,000}$
 $= .498\frac{1}{2}$. Hence, $.498\frac{1}{2} \times \$23.50 = \11.72 .

Shingles are sold in bundles of 250 ($\frac{1}{4}$ M). The lengths of all shingles in bundle are the same (usually 12 in., 14 in., or 16 in.), but their widths vary. The average width, however, is generally 4 in., the width of all bundles being alike. When laying shingles, 4 in. is usually exposed to the weather, the remaining portions being concealed by the other shingles.

Rule.—To find the number of shingles required to cover a roof, compute the total area of the roof in square inches, and divide this area by the product of the average width of the shingles and the length that is exposed to the weather.

EXAMPLE.—What will it cost to shingle a roof, each side measuring 40 ft. \times 16 ft., if the shingles cost \$4.50 per M?

SOLUTION.—Since the size of the exposed portion is not stated, it will be assumed as 4 in. \times 4 in. Then, for one side, $\frac{40 \times 16 \times 144}{4 \times 4} = 5,760$ shingles will be required, and for both sides, $5,760 \times 2 = 11,520$ shingles. Therefore, the cost will be $11.52 \times \$4.50 = \51.84 .

Multiply by 144 in order to reduce the square feet (40 \times 16) to square inches. Allowance should also be made for waste.

MASONRY

In estimating the cubical contents of stone walls, the *perch* of $24\frac{1}{2}$ cu. ft. is used.

Rule.—To find the number of perches of masonry in a wall, divide the volume of the wall in cubic feet by $24\frac{1}{2}$.

In estimating the contents of stone foundations for buildings, the length of the wall is measured on the outside, thus counting each corner twice. If a wall 2 ft. thick measures 12 ft. \times 20 ft. on the outside, and the corners are assumed to be parts of the longer sides, there will be 2 walls each 20 ft. long, and 2 walls each 8 ft. long. The actual length is therefore $2 \times 20 + 2 \times 8 = 56$ ft. The length estimated on the outside is $2 \times 20 + 2 \times 12 = 64$ ft. To find the actual length of such a wall, subtract 4 times the thickness of the wall from the length measured on the outside. Thus, in the above case, actual length = $64 - 4 \times 2 = 56$ ft.

Usually, masons make no allowance for windows or doors in estimating their work. In estimating the quantity of stone required for the wall, such allowances should be made.

EXAMPLE.—(a) How many perches of stone will be required to build the walls of a church 60 ft. long by

32 ft. wide, the walls being 24 ft. high and $2\frac{1}{4}$ ft. thick? There are 8 windows, each 5 ft. wide and 11 ft. high, and 2 doors, each 6 ft. wide and 9 ft. high. (b) What will be the cost of laying the walls at \$3.50 per perch?

SOLUTION.—

Length of wall (outside) = $2 \times 60 + 2 \times 32 = 184$ ft.

Actual length = $184 - 4 \times 2\frac{1}{4} = 175$ ft.

Actual cubical contents = $175 \times 24 \times 2\frac{1}{4} = 9,450$ cu. ft.

Allowance for windows = $5 \times 11 \times 2\frac{1}{4} \times 8 = 990$ cu. ft.

Allowance for doors = $6 \times 9 \times 2\frac{1}{4} \times 2 = 243$ cu. ft.

Net contents = $9,450 - (990 + 243) = 8,217$ cu. ft.

(a) Perches required for wall = $8,217 \div 24\frac{1}{4} = 332$.

(b) Since, in estimating the cost of the work, no allowance is made for corners, doors, and windows,

Cubical contents = $184 \times 24 \times 2\frac{1}{4} = 9,936$ cu. ft.

Perches of stonework = $9,936 \div 24\frac{1}{4} = 401\frac{1}{4}$.

Cost of laying walls = $401\frac{1}{4} \times \$3.50 = \$1,405.09$.

BRICKWORK

Brickwork is generally estimated by the thousand bricks laid in the wall, but measurements by the cubic yard and by the perch are also used. To allow for mortar, $\frac{1}{4}$ in. is added to the length and to the thickness in making calculations. The following data will be found useful in calculating the number of bricks in a wall. For each superficial foot of wall 4 in. in thickness (the width of 1 brick), allow $7\frac{1}{2}$ bricks; for a 9-in. wall (the width of 2 bricks), allow 15 bricks; and so on, estimating $7\frac{1}{2}$ bricks for each additional 4 in. in thickness of wall. If brickwork is to be estimated by the cubic yard, allow 500 bricks to 1 cu. yd. This figure is based on the use of $8\frac{1}{4}$ in. \times 4 in. \times $2\frac{1}{4}$ in. bricks, with mortar joints not over $\frac{3}{8}$ in. thick. If the joints are $\frac{1}{8}$ in. thick, as in face brickwork, 1 cu. yd. will require about 575 bricks. In making calculations of the number of bricks required, an allowance of, say, 5% should be made for waste in breakage, etc.

BINS, CISTERNS, ETC.

It is frequently necessary to estimate the capacity of a bin, box, or vessel in bushels, barrels, or gallons. The volume of the bin or vessel in cubic feet or cubic inches is divided by the number of cubic feet or cubic inches in a bushel, barrel, or gallon, as the case may be. For convenience of reference, the following table of capacities is given:

DRY MEASURE

1 heaped bushel	= 2,747.71 cu. in. = 1.59 cu. ft., nearly
1 stricken bushel	= 2,150.42 cu. in. = 1.25 cu. ft., nearly
1 peck	= 537.6 cu. in.
1 quart	= 67.2 cu. in.
1 pint	= 33.6 cu. in.

LIQUID MEASURE

1 hogshead	= 8.422 cu. ft.
1 barrel	= 4.211 cu. ft.
1 gallon	= 231 cu. in.
quart	= 57.75 cu. in.
1 pint	= 28.875 cu. in.

Rule.—*To find the capacity of a bin or other vessel in dry measure or in liquid measure, divide the volume of the bin or vessel in cubic inches by the number of cubic inches in the unit of measure.*

The following table of approximate capacities is very convenient in rough calculations:

1 cubic foot	= .63 heaped bushel
1 cubic foot	= .80 stricken bushel
1 cubic foot	= 7.50 liquid gallons
1 cubic foot	= $\frac{1}{8}$ barrel

The following short rules are approximate, but the results are sufficiently accurate for all practical purposes.

Rule.—*To find the capacity of a bin in heaped bushels, multiply the volume in cubic feet by .63.*

Rule.—*To find the capacity of a bin in stricken bushels, multiply the volume in cubic feet by .8.*

Rule.—*To find the number of gallons in a cistern or other vessel, multiply the volume in cubic feet by 7.5.*

Rule.—To find the number of barrels in a cistern, multiply the volume in cubic feet by $\frac{1}{18}$.

Rule.—To find the number of gallons in a cylindrical vessel, multiply the square of the diameter in inches by the height in inches, and that product by .0034.

GAUGING OF CASKS

A cask resembles two frustums of cones with their larger bases placed together.

The *bung diameter* of a cask is the diameter measured half way between the two ends; it is usually the greatest diameter.

The *mean diameter* of a cask is the mean between the bung diameter and the head diameter. The mean diameter is found by adding together the head diameter and bung diameter and dividing the sum by 2.

Rule.—To find the number of gallons in a cask, multiply the square of the mean diameter in inches by the length in inches, and that product by .0034.

EXAMPLE.—The diameter of a cask is 27 in. at the head, 33 in. at the bung, and the cask is 3 ft. long; how many gallons will it hold?

SOLUTION.—Mean diameter = $\frac{27+33}{2} = 30$ in. Length = 3 ft.
= 36 in. Capacity = $30^2 \times 36 \times .0034 = 110.16$ gal.

To find the number of liters in the cask, multiply by .0129 instead of .0034. If the cask is partly filled, stand it on end, find the mean diameter of the part filled, multiply its square by the height, and that product by .0034.

COAL AND HAY

A ton (2,000 lb.) of Lehigh coal, egg size, measures $34\frac{1}{2}$ cu. ft. in the bin; Schuylkill coal, 35 cu. ft.; pink-gray and red-ash coal, 36 cu. ft.; Wyoming coal, 31 cu. ft.

The bulk of a ton of hay is dependent on the pressure to which it is subjected. Roughly speaking, a ton of

hay lying unpressed measures 500 cu. ft.; when in a small stack, 400 cu. ft.; and in mows compressed with grain, or in well-settled stacks, 300 cu. ft.

Shipping Ton.—Freight on very light articles is usually estimated by the space occupied.

40 cu. ft. =	{	1 United States shipping ton
		31.16 imperial bushels
		32.143 United States bushels
42 cu. ft. =	{	1 British shipping ton
		32.719 imperial bushels
		33.75 United States bushels

POSTAL DISTANCES AND TIME

The distances of the shortest routes and the time by the fastest trains between New York City and the points indicated are given by the Official Postal Guide as follows:

<i>Cities in the United States</i>	<i>Miles</i>	<i>Hours</i>
Albany, N. Y.....	142	3½
Atlanta, Ga.	882	24¼
Baltimore, Md.	188	6
Binghamton, N. Y.....	207	5½
Bismarck, N. Dak.....	1,738	60½
Boise, Idaho	2,736	92½
Boston, Mass.	217	7
Buffalo, N. Y.	410	9½
Cape May, N. J.....	172	5
Carson City, Nev.	3,036	109¼
Charleston, S. C.....	804	21¼
Chattanooga, Tenn.	853	32
Cheyenne, Wyo.	1,899	54
Chicago, Ill.	900	23
Cincinnati, Ohio	744	23

<i>Cities in the United States</i>	<i>Miles</i>	<i>Hours</i>
Cleveland, Ohio	568	19½
Columbus, Ohio	624	20
Concord, N. H.	292	9½
Deadwood, S. Dak.	1,975	65½
Denver, Colo.	1,930	61½
Des Moines, Iowa	1,257	37½
Detroit, Mich.	743	21
Galveston, Tex.	1,789	56½
Harrisburg, Pa.	182	6
Hartford, Conn.	112	4
Helena, Mont.	2,423	89
Hot Springs, Ark.	1,367	55
Indianapolis, Ind.	808	23
Jacksonville, Fla.	1,077	32
Kansas City, Mo.	1,302	38¼
Louisville, Ky.	854	30
Memphis, Tenn.	1,163	40
Milwaukee, Wis.	985	29¼
Montgomery, Ala.	1,057	30½
Montpelier, Vt.	327	10¼
New Orleans, La.	1,344	40
Omaha, Neb.	1,383	43
Philadelphia, Pa.	90	3
Pittsburg, Pa.	431	13
Portland, Me.	325	12
Portland, Ore.	3,181	114½
Prescott, Ariz.	2,724	94
Providence, R. I.	189	6
Richmond, Va.	344	11¼
St. Louis, Mo.	1,048	29
St. Paul, Minn.	1,300	37
Salt Lake City, Utah.....	2,452	71½
San Francisco, Cal.	3,250	106
Santa Fé, N. Mex.....	2,173	82
Savannah, Ga.	905	26
Scranton, Pa.	146	4½
Tacoma, Wash.	3,209	102
Topeka, Kans.	1,370	48

<i>Cities in the United States</i>	<i>Miles</i>	<i>Hours</i>
Trenton, N. J.....	57	2
Vicksburg, Miss.	1,288	50
Vinita, Okla.	1,412	42
Washington, D. C.	228	6½
Wheeling, W. Va.	496	14¼
Wilmington, Del.	117	5
Wilmington, N. C.	593	20

The postal distances and time between New York and foreign cities are as follows:

<i>By Postal Route to</i>	<i>Miles</i>	<i>Days</i>
Adelaide, via Vancouver	12,845	31
Alexandria, via London	6,150	12
Amsterdam, via London	3,985	8
Antwerp, via London	4,000	8
Athens, via London	5,655	11
Bahia, Brazil	5,870	14
Bangkok, Siam, via San Francisco.....	12,900	43
Batavia, Java, via London.....	12,800	34
Berlin, via London	4,385	9
Bombay, via London	9,765	22
Bremen, via London	4,235	8
Buenos Ayres	8,045	24
Calcutta via London	11,120	24
Cape Town, via London.....	11,245	25.
Constantinople, via London	5,810	11
Florence, via London	4,800	9
Glasgow	3,370	8
Greytown, via New Orleans.....	2,815	7
Halifax, N. S.	645	2
Hamburg, via London	4,340	9
Hamburg, direct	4,820	9
Havana	1,366	3
Hong Kong, via San Francisco.....	10,590	27
Honolulu, via San Francisco.....	5,645	12
Liverpool	3,540	7
London, via Queenstown	3,740	7
London, via Southampton	3,760	8
Madrid, via London	4,925	9

POSTAL DISTANCES AND TIME

319

<i>By Postal Route to</i>	<i>Miles</i>	<i>Days</i>
Melbourne, via Vancouver	12,265	30
Mexico City (railroad).....	3,750	5
Panama	2,355	6
Paris	4,020	8
Rio de Janeiro	6,204	17
Rome, via London	5,030	9
Rotterdam, via London.....	3,935	8
St. Petersburg, via London.....	5,730	9
San Juan, Porto Rico.....	1,730	6
Shanghai, via San Francisco.....	9,920	25
Stockholm, via London.....	4,975	10
Sydney, via Vancouver	11,570	29
Valparaiso, via Panama.....	5,910	22
Vienna, via London.....	4,740	9
Yokohama, via San Francisco.....	7,345	20

GENERAL INFORMATION

LEGAL HOLIDAYS

Legal holidays are days set apart by statute or by executive authority for fasting and prayer, or those given over to religious observance and amusements, or for political, moral, or social duties or anniversaries, or merely for popular recreation and amusement under such penalties and provisions alone as are expressed in positive legislative enactments.

In the United States there are no established holidays of a religious character having a legal status without legislation. The days established by statutory or by executive authority, which are observed as legal holidays, are given in the list that follows:

January 1. *New Year's Day*: In all the states and territories except Massachusetts and New Hampshire.

January 8. *Anniversary of the Battle of New Orleans*: In Louisiana.

January 19. *Lee's Birthday*: In Alabama, Florida, Georgia, North Carolina, South Carolina, and Virginia.

February 12. *Lincoln's Birthday*: In Arizona, Connecticut, Colorado, Illinois, Minnesota, New Jersey, New York, North Dakota, Pennsylvania, Washington, and Wyoming.

February 22. *Washington's Birthday*: In all the states and territories except Mississippi and New Mexico.

March 2. *Texas Independence Day*: In Texas.

April 6. *Confederate Memorial Day*: In Louisiana.

April 19. *Patriot's Day*: In Massachusetts.

April 21. *Anniversary of the Battle of San Jacinto*: In Texas.

April 26. *Confederate Memorial Day*: In Alabama, Florida, and Georgia.

May 10. *Confederate Memorial Day*: In North Carolina and South Carolina.

May, Second Friday. *Confederate Memorial Day*: In Tennessee.

May 20. *Anniversary of the Signing of the Mecklenburg Declaration of Independence*: In North Carolina.

May 30. *Decoration Day*: In all the states and territories except Alabama, Arkansas, Florida, Georgia, Idaho, Louisiana, Mississippi, New Mexico, North Carolina, South Carolina, Texas, and Virginia.

June 3. *Jefferson Davis's Birthday*: In Alabama, Florida, Georgia, and South Carolina.

July 4. *Independence Day*: In all states and territories.

July 24. *Pioneer's Day*: In Utah.

August 16. *Bennington Battle Day*: In Vermont.

September, First Monday. *Labor Day*: In all the states and territories except Arkansas, Louisiana, Mississippi, Nevada, New Mexico, North Dakota, Oklahoma, and Vermont.

September 9. *Admission Day*: In California.

October 12. *Columbus Day*: In California, Colorado, Connecticut, Maryland, Missouri, Montana, New Jersey, New York, and Pennsylvania.

October 31. *Admission Day*: In Nevada.

November 1. *All Saints' Day*: In Louisiana.

November 25. *Labor Day*: In the parish of Orleans, Louisiana.

November, Fourth Thursday. *Thanksgiving Day*: In all the states and territories. The exact day is fixed by the proclamation of the President of the United States and the governors of the states.

December 25. *Christmas Day*: In all the states and territories.

Shrove Tuesday. *Mardi Gras*: In Alabama and in the parish of Orleans, Louisiana.

Good Friday: In Alabama, Louisiana, Maryland, Minnesota, Pennsylvania, and Tennessee.

Arbor Day: In Colorado, third Friday in April; Idaho, last Monday in April; in Nebraska, April 22; Utah, April 15. This day is observed in other states on dates appointed by the governors.

General Election Day, being the Tuesday after the first Monday of November in every year when such elections are held is a holiday in Arizona, California, Florida, Idaho, Illinois, Indiana, Iowa, Louisiana, Maryland, Minnesota, Missouri, Montana, Nevada, New Hampshire, New Jersey, New York, North Dakota, Oklahoma, Oregon, Pennsylvania, Rhode Island, South Carolina, South Dakota, Tennessee, Texas, Washington, West Virginia, Wisconsin, and Wyoming.

Sundays are holidays, and also any day appointed by the governor in any of the several states as a *fast day*, or a day for prayer. There are no statutory holidays in Mississippi, but by common consent the Fourth of July, Thanksgiving Day, and Christmas are observed as such. In Kansas the only legal holidays by legislative enactment are February 22, May 30, first Monday of September, and Thanksgiving Day, but by common consent New Year's Day, Fourth of July, and Christmas are also observed.

Saturday, after 12 o'clock noon, is a legal holiday throughout the year in Connecticut, District of Columbia, Florida, Maine, Maryland, Massachusetts, Michigan, Missouri, New Jersey, New York, Pennsylvania, Rhode Island, and Washington; in Louisiana and Missouri, in cities of 100,000 inhabitants and over; in Ohio and Virginia, in cities of 50,000 inhabitants and over; in Delaware, in the city of Wilmington and in Newcastle county, except St. George's Hundred, where Saturdays from June to September only are holidays; in South Carolina, in Charleston county; and in Colorado, in Denver during June, July, and August.

Holidays falling on Sunday are observed the day before in Kansas, Mississippi, Nevada, Vermont, and West Virginia, and on the same day in Louisiana; but elsewhere in the United States, on the following Monday.

In Canada the following are legal holidays in all the provinces: New Year's Day, Good Friday, Easter Monday, Christmas Day, the birthday of the reigning sovereign, any day appointed by proclamation for a public

holiday or a general fast or thanksgiving, and the day next following New Year's, Christmas, and the sovereign's birthday, when these days fall on Sunday. In Quebec, in addition to the above, the following are observed: The Epiphany, the Annunciation, the Ascension, Corpus Christi, St. Peter and St. Paul's Day, All Saints' Day, and Conception Day.

In England and Ireland the bank holidays are: Good Friday, Easter Monday, the Monday in Whitsun week, the first Monday in August, sovereign's birthday, Christmas, and the 26th of December if a week day; in Scotland, New Year's Day, Christmas (if either day fall on Sunday, then the following Monday), Good Friday, first Monday in May, first Monday in August, and the sovereign's birthday. In addition to the above, any day so proclaimed by the reigning sovereign is to be observed as a bank holiday throughout the United Kingdom, or in any part thereof.

CORRESPONDENCE

LETTER WRITING

The importance of letter writing, both in business and as an educational accomplishment, cannot be overestimated. Business must, to a large extent, be transacted by means of correspondence; and one of the leading requisites of business success is the ability to discharge the important duties pertaining to correspondence in a manner satisfactory to all concerned.

The essential parts of a letter are:

1. Heading, including date.
2. Address.
3. Salutation.
4. Body.
5. Complimentary close.
6. Subscription, or signature.
7. Superscription, or outside address.

The incidental parts are:

1. The postscript, with its continuations or iterations, paulo-postscript, post-paulo-postscript, and so on.
2. Nota bene.
3. Enclosure.
4. Stamp.
5. Return directions.

The writing of the place and date at the lower left-hand corner of the paper, at the end of a letter, though quite admissible and somewhat customary in the matter of social letters, is, in the case of business letters, annoying to those that desire to note at once the date of the letter. It is better not to indulge in any eccentricities in such matters. For people that do not have anything else to do it may be allowable; but busy people do not have time to look in unusual places for headings, addresses, signatures, etc.

The salutation is the greeting, as "Dear Sir," "Sir," "My dear George," and the like, with which it is usual to begin a letter. What the salutation shall be must be determined, of course, by the relation between the writer and the party addressed. The most formal, private, or unofficial salutations are "Sir" and "Madame." These are almost impersonal and belong to such persons as we may wish to accost with civility. "Sir" is the correct salutation in addressing officers of the government who have no special title inherent in the office they hold. When it is used the complimentary close should be "Yours respectfully," or something correspondingly distant.

General Form.—The following letter shows the usual arrangement of the various parts of an ordinary business letter. If the street address is given in the heading, the heading and date should be written in two lines; if the street address is not given, the heading and date should be written in one line. The address, if of more than two lines, should be neatly balanced. A colon should follow the salutation; a dash is often used after the colon, but this is unnecessary.

(Heading and Date)

540 Sewell St., PORTLAND, ME.,
February 22, 1912.

(Address)

MR. JOHN W. PLAYFAIR,
President First National Bank,
558 Jackson Boulevard,
Chicago, Ill.

(Salutation)

DEAR SIR:

(Body)

Mr. George Williams of your city has called to interest me in the purchase of a large tract of timber and mining lands in Northern Wisconsin. Mr. Williams impresses me favorably, and his propositions appear quite reasonable on their face.

I have, however, deferred giving him a final answer until I hear from you regarding his standing in business circles in Chicago. He speaks of you as an acquaintance, and since I claim you as a friend, your advice will be as welcome as it must be valuable.

(Complimentary Close)

I am, dear sir,

Very sincerely yours,

(Signature)

WILLIAM HUTCHESON.

The superscription is the outside address—the one written on the envelope, and the one for the postmaster and

Return in 5 days to
540 Sewell St.,
Portland, Me.

Stamp

MR. JOHN W. PLAYFAIR,
President First National Bank,
558 Jackson Boulevard,
Chicago, Ill.

with an expression of compliment or affection in addition to the complimentary close.

Promptness of Answers.—From the standpoint of the recipient of the letter, correspondence demands close and courteous attention. Letters, especially business letters, should be answered with reasonable promptness.

Date of Letter Answered.—The answer to a business letter should contain a reference to the date of the letter answered; thus, "In answer to your letter of the 10th inst."

Enclosing Stamp.—A letter asking a favor or treating of business in which only the writer and not the recipient is interested, should have a stamp enclosed for an answer.

Legibility.—Do not write so that your correspondent will be unable to read your letter, or meet with great difficulty in so doing. Sign your name to the letter, so that there can be no possible doubt as to the spelling. Some business men cultivate a characteristic signature, which they use for checks and business papers. Such a signature is often purposely almost illegible, and obviously should not be used for a letter except to a well-known correspondent.

FIRST AID TO THE INJURED

PREPARATION

Where a large number of persons are employed and accidents are liable to occur, a supply of articles should be available. The necessary articles should include one or more stretchers, cotton, carron oil (equal parts of turpentine and water), splints, soap, towels, and bottles of ammonia, etc. The necessity for these or other articles depends on the nature of the work.

the letter carrier to note. Like the address, the superscription consists of three parts: the name, the title, and the business address or residence.

The accompanying illustration shows a specimen superscription.

SUGGESTIONS

The first and most important rule to be observed by a writer of a letter is to *be courteous*.

Neatness.—Always be careful, in the writing of a letter, to avoid blots, corrections, or erasures. Make the letter perfect as to neatness, even if it has to be rewritten. An essential as important as neatness is correct spelling.

Brevity.—One of the essential qualities of business correspondence that cannot be too strongly dwelt upon is *brevity*, for business men have no time to waste, and appreciate conciseness of expression. Brevity of expression, if combined with neatness, clearness, and courtesy always makes a good impression upon the true business man. One of the greatest helps to success in any walk of life is the ability to express ideas accurately and concisely.

Deliberation.—No one should write a letter when angry, nor, as a rule, when inclined to say severe things. If one receives a letter provoking him to anger, it is better to wait a little before answering; then probably the style of his reply will be entirely changed. Words hastily spoken, and letters written in haste or anger, one usually would like to recall. Hasty or vindictive words make enemies and endanger business, while kind words make and hold friends. Make it a rule never to write a letter when strongly excited.

Many writers experience difficulty in the opening and closing sentences of a letter. The opening should be perfectly natural and should introduce the subject uppermost in the mind. Avoid in the opening such set phrases as "I now take my pen in hand to tell you that I am well, etc.," "I thought I would drop you a line to let you know, etc." A familiar letter usually ends

with an expression of compliment or affection in addition to the complimentary close.

Promptness of Answers.—From the standpoint of the recipient of the letter, correspondence demands close and courteous attention. Letters, especially business letters, should be answered with reasonable promptness.

Date of Letter Answered.—The answer to a business letter should contain a reference to the date of the letter answered; thus, "In answer to your letter of the 10th inst."

Enclosing Stamp.—A letter asking a favor or treating of business in which only the writer and not the recipient is interested, should have a stamp enclosed for an answer.

Legibility.—Do not write so that your correspondent will be unable to read your letter, or meet with great difficulty in so doing. Sign your name to the letter, so that there can be no possible doubt as to the spelling. Some business men cultivate a characteristic signature, which they use for checks and business papers. Such a signature is often purposely almost illegible, and obviously should not be used for a letter except to a well-known correspondent.

FIRST AID TO THE INJURED

PREPARATION

In every place where a large number of persons are employed and where accidents are liable to occur, a supply of articles needed to render first aid should be available. These should include one or more stretchers, bandages, absorbent cotton, carron oil (equal parts of raw linseed oil and lime water), splints, soap, towels, blankets, aromatic spirits of ammonia, etc. The necessary quantity of any of these or other articles depends on the nature and size of the works.

Sterilizing.—Many disease germs may be killed by heat; others by chemicals called disinfectants, such as bichloride of mercury, carbolic acid, etc. The solutions used in washing wounds should be made up of about the following strengths: Bichloride of mercury, 15 gr. to 1 qt. of water; or, liquid carbolic acid, 2 teaspoonfuls to 1 qt. of water. The substances should be thoroughly dissolved before the solution is used.

ACCIDENTS AND INJURIES

FAINING

Fainting, or *swooning*, with loss of sensation, motion, and consciousness, may result from a severe blow or wound, from loss of blood, from great emotion (extreme fear or joy), from electric shock, etc. The patient becomes pale, inanimate, and is in a condition of apparent death; if not soon relieved, death may result.

The patient should be laid with the head lower than the feet, and ligatures or bands of some sort should be



FIG. 1

tied around the arms and legs close to the body, so as to confine the circulation to the trunk and head. The tongue should be kept out of the throat, in order to allow free access of air, and the respiration may be

helped by pressing in and down on the ribs and chest and allowing the chest to expand by its own elasticity.

Artificial Respiration.—The process just described is one form of *artificial respiration*, and may in some cases be effective. If the desired results are not soon obtained, place the patient on his back with a pad (a roll of clothing will do) under the back just below the shoulders, so as to raise the pit of the stomach. The patient's tongue should be drawn out and held by an assistant, or, it should be fastened against the lower teeth by a rubber band passing under the chin or clasped between the patient's teeth, the lower jaw being held up by a bandage tied over the head. Grasp the forearms half way between the elbows and wrists, and draw the arms back rather quickly but steadily in vertical planes until they meet above the patient's head, as in Fig. 1, and hold them thus for 2 sec. This motion draws the ribs up, expands the chest, and air enters. Now bring the arms back to the sides of the body, and press firmly



FIG. 2

on the sides and front of the chest over the lower ribs, as in Fig. 2; the object of this movement is to contract the chest and force the air out of the lungs. If enough assistants are present, one can stand astride the patient and press firmly against the sides and top of the chest

while the arms are held down along the sides. This series of movements, constituting one inspiration and one expiration, should be repeated about once every 4 sec., or fifteen times per min., for $1\frac{1}{2}$ or 2 hr. if necessary, unless in the meantime a physician pronounces life extinct. While working over the patient prevent unnecessary crowding of persons, avoid rough usage, and do not allow the patient to remain on his back unless his tongue is secured. Under no circumstances should the patient be held up by his feet, nor should be placed in a warm bath unless under medical direction.

TRAUMATIC SHOCK

Severe injuries may sometimes result in *traumatic shock* (*trauma* meaning wound), in which the victim appears confused and listless and perhaps stupefied, but not unconscious. The pulses and respiration are perceptible, though feeble and irregular. Sometimes the bowels move involuntarily. Intelligence is not usually wholly lost, and the patient can be made to respond to questions if repeatedly urged. This condition may last a few moments or several hours, and may terminate in death.

Place the patient in a horizontal position with head lowered, and warm him by rubbing and by using warm linen or blankets. Let him inhale the odor from dilute ammonia water. If he can swallow, give a little hot brandy and water with a few drops of ammonia water added; 1 teaspoonful of aromatic spirits of ammonia in a wineglassful of water is also good. From 2 to 4 teaspoonfuls of turpentine in a quart of water, as hot as may be used without discomfort, may be injected into the bowels, often with good results.

Wounds consisting of severe bruises are sometimes characterized by numbness, coldness, and absence of bleeding until reaction begins. In such cases, use stimulants and antiseptics and keep the injured part as quiet as possible and protected by warm dressing.

HEMORRHAGE, OR BLEEDING

Hemorrhage, or *bleeding*, may come from the arteries, the veins, or the capillaries. The arteries are the channels through which blood flows from the heart to the various parts of the body, and the veins are the channels through which the blood returns to the heart. The capillaries form the network of very minute tubes through which the blood passes from the arteries to the veins and by which all the tissues of the body are nourished.

Arterial hemorrhage is usually distinguished by the bright red color of the blood and the regular pulsations with which it issues from the blood vessels; *venous hemorrhage* can be known by the dark-blue tint of the blood and the steadiness of its flow; in *capillary hemorrhage*, the blood has a reddish tint and exudes from the tissues or wells up from the surface of the wound. *Internal hemorrhage* may exist without any external flow of blood.

After excessive loss of blood, the patient's face and lips turn pale; he experiences chills, cold sweats, nausea, frequent vomiting, irregular respiration, feeble pulse, dizziness, buzzing in the ears, and finally unconsciousness, terminating either in death or in cessation of the bleeding. In the latter case, consciousness may soon return, but very often the tendency to fainting fits persists for a time.



FIG. 3

Capillary hemorrhage is arrested by bathing the wounded part in cold sterilized water and bandaging it with a pad, or compress of sterilized gauze or lint.

Venous hemorrhage is more serious and cannot always be stopped by binding a pad over the wound; in this case, the limb must be bandaged on the side of the wound away from the heart. The limb should be raised and held above the

rest of the body and the patient should be made to lie perfectly quiet.

Arterial hemorrhage is more serious than either of the others. If a large artery or a number of small ones are ruptured, the blood may escape so rapidly that death occurs almost at once. Pressure enough to stop the flow should be applied to the artery where it passes over a bone between the wound and the heart. The location of the artery is revealed by the distinct pulsations. Pres-

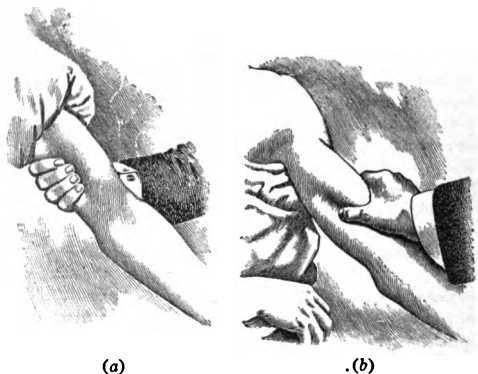

FIG. 4

sure applied with the fingers will answer temporarily, and this method affords a way of finding the proper spot on which to press. A knot or any hard substance, in a handkerchief or a bandage may then be placed on the spot, tied loosely around the limb, and twisted with a stick, as in Fig. 3, until bleeding ceases. The stick may be then be fastened with another bandage.

The course of the main (brachial) artery in the arm is well indicated by the inner sleeve seam of a man's coat; this artery can be compressed by grasping the arm by

either method (a) or (b), Fig. 4. The pressure should always be downwards against the bone and not against



FIG. 5



FIG. 6

soft muscle. The subclavian artery supplying blood to the arm may be closed by applying pressure in the hollow just above the collar bone, as shown in Fig. 5. The temporal artery runs up the side of the forehead, and may be closed by applying a pad, as in Fig. 6. The femoral artery runs from the groin down a little inside of the front of the leg about one-third the distance to the knee, then passes through the muscles and approaches the surface again behind the knee.



FIG. 7

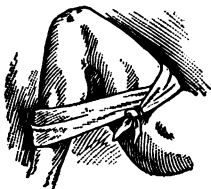

FIG. 8

Pressure applied as at *P*, Fig. 7, may stop bleeding from a wound above the knee, and a pad applied as in Fig. 8 is applicable for a wound below the knee.

ELECTRIC SHOCK

Electric shock may produce severe burns, unconsciousness, or death, depending on the strength of the current through the body as well as on its duration and flow. If the skin is thin and moist and the contacts with the conductors good, comparatively low voltage, 220 or possibly less, may be sufficient to send considerable current through the body. On the other hand, a person with thick, dry skin, as on the palms of the hands, may sometimes make slight accidental contact with a circuit of several thousand volts without serious results. A very small current through the region of the heart may paralyze its action and cause death; currents of greater density stimulate the heart to increased action, but paralyze the nerve centers controlling respiration and may cause death by suffocation, the same as in drowning.

Accidental contact with an electric conductor should be broken as quickly as possible; if maintained until heart action ceases, as a result of suffocation, death invariably results. In breaking the contact (provided, of course, the power cannot be immediately turned off the circuit), use the feet to push the victim and the conductor apart—never the hands. Current passing from one foot through the legs and the other foot to ground does comparatively little injury, since the important nerve centers and the heart are not in its path. As soon as the contact is broken, the victim, if he has not lost consciousness, soon recovers. If the victim is unconscious but has not ceased breathing, an effort should be made to revive him, the same as in an ordinary fainting fit. If respiration has ceased, artificial respiration should be tried and continued for some time, even though the heart action is so feeble as to be almost imperceptible. The first and most important requirement in producing respiration by artificial means is to hold the tongue so that it cannot obstruct the throat.

Burns caused by contact with electric conductors should be protected with sterilized gauze. Such burns

are generally deep, sometimes even carbonizing the bones, especially those of the fingers. They heal quickly, however—ordinarily in from 3 to 6 weeks.

WOUNDS

Before being used on a wound, all instruments, bandages, etc., should be sterilized by heating in steam or boiling water or by baking or by treating with a germ-destroying solution. The water used in washing a wound should first be boiled, in fact nothing unsterilized should be permitted to come in contact with the wounded surface. The germs entering a wound from the skin of the patient or from the object that produced the wound may be removed by thoroughly washing with sterilized water, and the sterilized dressings will prevent further infection.

The first treatment of a wound includes checking the bleeding; the removal of all foreign matter and a thorough washing; drawing the lips of the wound together or gently straightening bruised or torn flesh; applying several layers of sterilized gauze, with absorbent cotton next the wound if it is likely to bleed or discharge, and holding all in place with a suitable bandage. Sterilized adhesive strips are sometimes necessary to hold the wound together.

FRACTURES

The signs of *fracture* are: (1) Loss of power in the limb, or part, injured. (2) Pain and swelling at the seat of the injury. (3) Distortion of the injured limb—it will be longer or shorter than the other or will lie in some unnatural position. By gentle pulling, the limb may be brought back to its natural shape, but on being released will immediately return to the distorted position. (4) On gently moving the limb, a grating sensation (crepitation) may be felt where the ends of the broken bone rub against each other. (5) If near the surface, the break may be felt from the outside. A fracture should be handled with extreme gentleness; rough usage may do much harm.

Before attempting to move a patient suffering from fracture, the injured part should be supported in a rigid

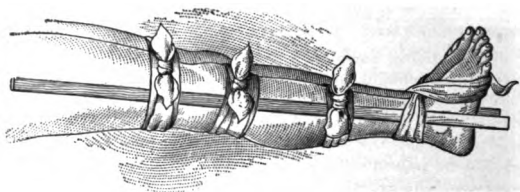

FIG. 9

position by tying on splints. Almost any substance stiff enough to support the injured part will answer for a temporary splint; for example, a stocking leg or a coat sleeve filled with earth, sand, moss, hay, chaff, or paper and securely tied at each end, a barrel stave, a piece of board, a roll of paper, etc. If hard substances are used for splints, the leg should be padded. If feasible, the splints should extend past the nearest joints, and should be securely bandaged so that both the fracture and the joints are held rigid, as in Fig. 9.

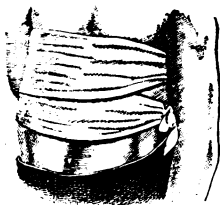

FIG. 10

Until the physician comes, a fractured jaw should be held in place by a bandage passed under the chin and over the head. If the collar bone is broken, the arm should be raised gently, and a pad made by tightly rolling a handkerchief or a piece of cloth should be placed in the armpit; the forearm

should be supported horizontally across the chest by a large arm sling, and the arm and sling should be held firmly in position by a broad bandage placed around the

body and just above the elbow. Fractured ribs may be temporarily treated by fastening broad bandages around the body, tying the knot on the side opposite the fracture, as in Fig. 10.

DISLOCATIONS AND SPRAINS

A *dislocation* is the displacement of the bones of a joint. Ordinarily, a physician is needed, and little can be done before his arrival except to make the patient as comfortable as possible.

A *sprain* should be kept very quiet. If possible, keep the injured member in water as hot as can be borne for 1½ hr. or more; then bandage with moderate firmness in such a manner as to prevent any movement of the joint, using splints for this purpose if necessary.

EFFECTS OF HEAT

Burns.—The general treatment of a burn consists in relieving the pain, in combating the depression, and increasing the warmth of the patient. The pain may usually be relieved by excluding the air from the burned portion; stimulants should be given, if necessary, to relieve the depression. A covering of flour may be spread over the burned surface; or bicarbonate of soda, either in the form of paste or powder, can be used; any oil, such as sweet oil, raw linseed oil, or carron oil, or a dressing, such as vaseline, cold cream, etc., is effective.

In removing the clothing from over a burn or in dressing it, the blisters should not be broken. If any clothing adheres, it should be saturated with oil and allowed to remain. The patient should not be exposed to cold.

Heat exhaustion is generally accompanied by weakness, cool skin, pale face, weak voice, rapid and feeble pulse, increased respiration, dim vision, and possibly by unconsciousness. The patient should be placed in a horizontal position with the head low, and stimulants and hot applications should be administered. Occasional doses of brandy should be given, also a teaspoonful of

aromatic spirits of ammonia in a little hot milk or water every half hour. If the patient cannot swallow, these remedies may be injected into the rectum.

Sunstroke, which may occur in any hot, moist temperature, is accompanied by high fever. In a few cases, unconsciousness and death come very quickly; but usually the progressive symptoms are intense headache, dizziness, oppression, nausea, vomiting, occasionally diarrhea, and unconsciousness with delirium and restlessness. The face is flushed, the eyes bloodshot, the skin very hot and dry (temperature from 107° to 112° F.), the breathing labored and sometimes noisy, and the pulse frequent and full.

Both the symptoms and the treatment are directly opposite those for heat exhaustion. In cases of sunstroke, every effort should be made to reduce the excessive bodily temperature. Rubbing with ice, a cold bath, a cold pack, and cold rectal injections are all good.

RESTORING OF APPARENTLY DROWNED PERSONS

TREATMENT WHEN SEVERAL ASSISTANTS ARE AT HAND

As soon as the patient is taken from the water, expose the face to the air, toward the wind if there is any, and wipe dry the mouth and nostrils; rip the clothing so as to expose the chest and waist, and give two or three quick, smarting slaps on the chest with the open hand. If the patient does not revive, proceed immediately to expel water from the stomach and chest, as follows: Separate the jaws and keep them apart by placing between the teeth a cork or small bit of wood; turn the patient on his face, a large bundle of tightly rolled clothing being placed beneath the stomach (see Fig. 1);

press heavily on the back over the stomach for $\frac{1}{2}$ min., or as long as fluids flow freely from the mouth.

To Produce Breathing.—Clear the mouth and throat of mucus by introducing into the throat the corner of a handkerchief wrapped closely around the forefinger; turn the patient on the back, the roll of clothing being so placed as to raise the pit of the stomach above the level of the rest of the body (see Fig. 2). Let an assistant, with a handkerchief or piece of dry cloth, draw the tip of the tongue out of one corner of the mouth (which prevents the tongue from falling back and



FIG. 1

choking the entrance to the windpipe), and keep it projecting a little beyond the lips. Let another assistant grasp the arms just below the elbows and draw them steadily upwards by the side of the patient's head, and to the ground, the hands nearly meeting (which enlarges the capacity of the chest and induces inspiration). While this is being done, let a third assistant take a position astride the patient's hips, with his elbows resting on his own knees, his hands extended ready for action. Next, let the assistant standing at the head turn down the patient's arms to the side of the body

(see Fig. 3), the assistant holding the tongue changing hands, if necessary, to let the arm pass. Just before the patient's hands reach the ground, the man astride the body will grasp the body with his hands, the balls of the thumbs resting on either side of the pit of the stomach, the fingers falling into grooves between the short ribs. Now, using his knees as a pivot, he will at the moment the patient's hands touch the ground throw (not too suddenly) all his weight forwards on his hands, and at the same time squeeze the waist between them, as if he wished to force something in the chest upwards out of the mouth; he will increase



FIG. 2

the pressure while he slowly counts one, two, three, four (about 5 sec.), then suddenly let go with a final push, which will spring him back to his first position. This completes expiration.

At the instant the pressure is taken from the waist the man at the patient's head will again steadily draw the arms upwards to the sides of the patient's head, as before (the assistant holding the tongue again changing hands to let the arm pass, if necessary), holding them there while he slowly counts one, two, three, four (about 5 sec.).

Repeat these movements, deliberately and perseveringly, 12 to 15 times in every minute—thus imitating the natural motions of breathing.

If natural breathing is not restored after a trial of the bellows movement for the space of about 4 min., then turn the patient a second time on the stomach, rolling the body in the opposite direction from that in which it was first turned, for the purpose of freeing the air passage from any remaining water. Continue the artificial respiration from 1 to 4 hr., or until the patient breathes, according to the preceding instructions;



FIG. 3

and for a time, after the appearance of returning life, carefully aid the short gasps until deepened into full breaths. Continue the drying and rubbing, which should have been unceasingly practiced from the beginning by assistants, taking care not to interfere with the means used to produce breathing. Thus, the limbs of the patient should be rubbed, always in an upward direction toward the body with firm, grasping pressure and energy, using the bare hands, dry flannels, or handkerchiefs, and continuing the friction under the blankets or over the dry clothing. The warmth of the body can also be promoted by the application of hot flannels to the

stomach and armpits and bottles or bladders of hot water, heated bricks, etc. to the limbs and soles of the feet.

After Treatment.—When breathing has been established, let the patient be stripped of all wet clothing, wrapped in blankets only, put to bed comfortably warm, but with free circulation of fresh air, and left to perfect rest. Give whisky, or brandy, and hot water in doses of a teaspoonful, or a tablespoonful, according to the weight of the patient, or any other stimulant at hand, every 10 or 15 min. for the first hour, and as often thereafter as may seem expedient. After reaction is fully established, there is great danger of congestion of the lungs, and if perfect rest is not maintained for at least 48 hr. it sometimes occurs that the patient is seized with great difficulty of breathing, and death is liable to follow unless immediate relief is afforded. In such cases, apply a large mustard plaster over the breast. If the patient gasps for breath before the mustard takes effect, assist the breathing by carefully repeating the artificial respiration.

The foregoing treatment should be persevered in for some hours, as it is an erroneous opinion that persons are irrecoverable because life does not soon make its appearance.

MODIFICATION OF TREATMENT

To Produce Respiration.—If no assistant is at hand and one person must work alone, place the patient on his back with the shoulders slightly raised on a folded article of clothing; draw forward the tongue and keep it projecting just beyond the lips; if the lower jaw be lifted, the teeth may be made to hold the tongue in place; it may be necessary to retain the tongue by passing a handkerchief under the chin and tying it over the head. Grasp the arms just below the elbows and steadily draw them upwards by the sides of the patient's head to the ground, the hands nearly meeting, as shown

in Fig. 1. Next, lower the arms to the sides and press firmly downwards and inwards on the sides and



FIG. 1

front of the chest over the lower ribs, drawing toward the patient's head, as shown in Fig. 2. Repeat these movements 12 to 15 times every minute, etc.



FIG. 2

Remarks.—Prevent unnecessary crowding of persons round the body, especially if in an apartment.

Under no circumstances hold the body up by the feet.

On no account place the body in a warm bath, unless under medical direction, and even then it should be employed only as a momentary excitant.

**Promotion
Advancement in Salary
and
Business Success**

**Secured
Through the**

POULTRY FARMING

**Poultry Breeding
General Farming
Soil Improvement
Farm Crops**

LIVESTOCK AND DAIRYING

COURSES OF INSTRUCTION

OF THE

**International
Correspondence Schools**

**International Textbook
Company, Proprietors**

SCRANTON, PA., U. S. A.

SEE FOLLOWING PAGES

\$141.76 Profit from 100 Pullets in Six Months

I am still in the same position as when I enrolled, but on one hundred pullets have made the price of the Course a couple of times over, besides my regular wages. I intend to stay right at this until I can start in business for myself. I enjoy the Course ever so much and have the chicks here and can try on them things that I learn from the Course, even to caponizing.

I raise 90 per cent. of all chicks from one day old. Here is my egg record for the last 6 months and I never owned a chicken before enrolling in your Course.

<i>Cost of Feed</i>	<i>Eggs</i>	<i>Sold for</i>	<i>Rent</i>	<i>Profit</i>
Jan. \$19.00	1803	\$59.61	\$2.00	\$38.61
Feb. 22.20	1745	42.00	2.00	17.80
Mar. 14.88	1792	38.40	2.00	16.52
Apr. 19.75	2225	43.77	2.00	22.02
May 11.54	2411	55.35	2.00	21.81
June 18.00	1930	45.00	2.00	25.00

I had about one hundred and fifteen pullets in January and now have about one hundred. I am pretty proud of that record, so you can guess what I think of your Course.

R. C. MAXWELL, Pittsfield, Mass.

NOW A MANAGER

OTTUS SHUMAN, R. F. D. No. 3, Seymour, Conn.: "I was a moulder, 27 years old, when I enrolled with the I.C.S. for the Poultry Farming Course. I must say that it is all right in every respect, since it has been the means of securing for me a position as manager of a poultry farm. I now use the Course as my guide and am having good success in every line. It has proved itself more valuable than anything of the kind that I have ever seen, covering the subject thoroughly from beginning to end. It is well worth the price to any one whether he wishes to follow out the Course in a professional way or only by keeping a few chicks in the back yard. I cheerfully offer my indorsement and would recommend it to any one who is interested in the subject."

AN I.C.S. COURSE IS BEST

A. E. EASTMAN, 80 Parker St., Manchester, N. H.: "Your Course in Poultry Farming treats the subject thoroughly in all its branches. Although I have read many poultry books and am a subscriber to several poultry papers, I received many valuable suggestions from the Course that I have been unable to obtain from any other source. I can cheerfully recommend your Course of instruction to any one desiring a full knowledge of poultry raising."

A PRIZE WINNER

FRED T. BEDURTHA, 164 Crescent St., Athol, Mass.: "I was a mechanic at the time I enrolled with the I.C.S. for the Poultry Farming Course. I take pleasure in recommending this to the experienced poultryman, as well as to the novice. I found your Course interesting and practical, covering the subject in a most thorough manner. From it I have acquired much knowledge that years of practical experience did not reveal. I have won prizes at some of the leading shows, including three consecutive years at Boston."

A GRADUATE'S SUCCESS

W. A. SLATER, Jamestown, N. Y.: "Your I.C.S. Poultry Course I found very practical and a benefit to me in many ways. When I started into the chicken business, the second year I lost fifty per cent. of my stock. After graduating from your Course, I have this year raised ninety-five per cent. of the chicks hatched and have succeeded in getting more eggs from my flock than ever before. I am now manager of Slater's Poultry Farm."

BROKER'S CLERK WINS SUCCESS

EDWARD MCCOY, 161 Madison Ave., Hasbrouck Heights, N. J.: "At the time I enrolled with the I.C.S. for the Poultry Farming Course, I was employed by a brokerage house at a small salary. Having completed the Course I purchased a small place and in ten months found myself conducting a poultry plant with 600 laying pullets. Your Course is responsible for my success, and I find it better than you claim it to be. I can recommend it to any one, since it leads to success."

Failed Repeatedly—Now Successful

I cannot recommend your Course in Poultry Husbandry too highly, as it has made me a success after repeated failures. It is the most complete Course in Poultry Husbandry that has ever come to my notice. It covers every branch and detail of poultry farming. I have bought about every book advertised, the writers of which gave an outline of how they ran their farms but stopped at the gate, but your Course taught me how to raise my own poultry and run my little farm. Your Course taught me what to do and why to do it. I am no longer in the dark concerning poultry. My hens laid 70 per cent. more eggs in the first half of this year than they ever laid in a whole year before. Your lessons on diseases of poultry have saved many a growing chick for me this season. My loss of young chicks this season through natural causes has been less than 7 per cent. of all chicks hatched. Last season my loss from natural causes was about 60 per cent.

Every person that contemplates going into the poultry business, or those who have failed, should enroll in your Schools, for it will make one a success from the start, and it will make a success out of a failure.

WM. T. SCHEIDE,
R. F. D. 1, Lima, Ohio.

A BOY'S SUCCESS

HENRY HEINZ, Block Island, R. I.: "I began to study your Poultry Course when I was only 12 years old. At the beginning of my Course my father had to tell me to study the lessons, but I soon got interested in them without his telling me. As I am only 13 years old I do not think my opinion is worth very much, but I think the Course is very good. We raised between 250 and 300 chickens without losing one through sickness."

AN I.C.S. COURSE WOULD HAVE SAVED HIM \$5,000

WALTER B. DAVIS, Davis Poultry Farm, Kings Highway, East 23d St., Brooklyn, N. Y.: "I have about completed your Course on Poultry Farming and I beg to state that I consider it the greatest asset a poultry farmer can have to begin with. It covers the details in every way. From my own personal experience I can safely say that had I been familiar with this Course a year ago I would have saved \$5,000 on my poultry farm. (This figure is a conservative estimate.)"

AN I.C.S. COURSE TURNS FAILURE INTO SUCCESS

FRANK KRUEGER, 325 N. 15th St., Philadelphia, Pa.: "Some years ago I had a farm of my own in the lower part of New Jersey and had some chickens, but owing to my lack of knowledge in raising and feeding them I did not succeed. Since I have taken my I.C.S. Course in Poultry Farming, I realize how much I did not know. I am sure that any one following the path of knowledge set forth in your Instruction Papers is bound to succeed and achieve results far beyond his expectation."

A CITY MAN'S SUCCESS

J. K. SHAUGHNESSY, Agawam, Mass.: "I had always hankered for country life and chickens. If any man will invest in the I.C.S. Poultry Farming Course he will have no trouble to make a success of the business. My present position, secured through your Students' Aid Department, is that of manager and half owner of the Sanitary Poultry Yards. We have a capacity of 1600 layers and expect to increase each year. I am dry picking all my market stock and am getting ten cents more per pound than any man around this section and also top prices for my eggs."

GAINED A POSITION AS MANAGER

C. W. LARSON, R. F. D. No. 3, Box 40-A, St. Paul, Minn.: "I was working as a clerk when I enrolled with the I.C.S. for the Poultry Farming Course. I would strongly advise any one who contemplates going into the poultry industry to take up this Course which will assure him all success. It was because I was known to be a student of your Course that I was able to secure a position as manager of the Victoria Poultry Farm, an up-to-date plant, at a good salary. You are at liberty to refer prospective students to me."

The I. C. S. a Public Benefactor

I have just received my Diploma in your Agricultural Course, and am much pleased with the painstaking manner in which my Instruction Papers were handled by your people. The proposition, in a nutshell, is that, if the student does his (or her) part, the I. C. S. will do theirs.

The benefits to be derived from a Course in Agriculture in the I. C. S. are manifold; the most important, perhaps, is that it teaches the tiller of the soil to grow not only a better crop, but realize a greater production, as well as to do it with a great deal less of labor and expense, thereby making the tilling of the soil more of a pleasure than a drudge. Farmers, as well as others, are waking up to the truth that scientific farming is the only proper method to pursue, especially in these days of worn-out land, problems of drainage, and other things too numerous to mention. In this connection, your instruction on manures is worth the price of the whole Course. I might say the same of your instruction on drainage, etc.

I have endeavored to make my letter brief, but, on account of the great scope or magnitude of your Agricultural Course, it would be difficult to say it all upon a hundred sheets of paper of this size.

Any one who can show how two plants can be grown where but one could be made to grow before, and with less labor, expense, etc., is no less than a public benefactor, and this you do in your Agricultural Course.

WAYNE CANFIELD
84 Madison St., Wilkes-Barre, Pa.

PAID FOR HIS COURSE WITH 15 HENS

WILBUR H. DRESHER, Jeddo, Pa., writes that he has been able, through the knowledge gained from our Poultry Farming Course, to make 15 hens pay the price of his Course in less than 1 year. He praises the Schools for teaching him how to reduce his feed bills through scientific feeding, and for showing him how to take care of the health of his flock.

PROFITS INCREASED ONE-THIRD

CHAS. THEM, 6712 Dittman St., Tacony, Pa., has written an enthusiastic letter to the I.C.S. praising our Poultry Farming Course for stating facts clearly and concisely. Mr. Them is a saw maker, interested in poultry. Since taking our Course he has increased his profits one-third over last year's earnings. He states that he has found the Course far better than he expected, and that he cannot recommend it too highly.

AFTER 15 YEARS' EXPERIENCE THE I.C.S. BROUGHT SUCCESS

JOHN B. GALLAGHER, 418 Broad St., Bethehem, Pa.: "In 15 years of poultry keeping I have not had such a successful winter as the present one and I have had only the I.C.S. to thank for my success. I thought that I knew how to keep poultry, but every lesson taught me new points. I consider the Course the best investment of my life and any one interested in poultry will do well with poultry and soon learn to make money from them. If they take this Course, it will be money well spent."

DID NOT LOSE A SINGLE CHICK

ALDEN C. THURSTON, Rockport, Me.: "I have been raising fine chicks since last February, both naturally and artificially, and up to the present time I have not lost a single chick, for which I give credit to the instruction contained in the Poultry Farming Course of your Schools."

NOW PROPRIETOR

RAY L. CHAMBERLIN, North New Salem, Mass., was working for \$40 a month when he enrolled for the Complete Poultry Course. Since receiving his diploma he has become manager and half owner of the Wyolette Poultry Yards. He declares that the lessons on diseases and enemies of poultry are worth the price of the whole Course; also, that the lesson on poultry feeding has made a big increase in his egg yields.

NOW MANAGER

WM. M. FRESHLEY, Berea, Ohio, declares that he has gained considerable help from his I.C.S. Poultry Farming Course. He is now manager for H. Cecil Sheppard, originator of Sheppard's Famous Anconas. He recommends the course to poultrymen as well as to beginners.

Proprietor of a Prosperous Business

Before I enrolled with the I. C. S. for the Poultry Farming Course I was in the milk business. Since enrolment I sold out and now devote all my time to poultry. I found no difficulty in completing my Course and I have to thank the I. C. S. for putting me where I am today. No one going into the poultry business for profit can do without the I. C. S. Course. There is much to learn and the Course will take you over all the dangerous places in safety. There is no branch of the poultry business omitted. I am at present making about three times as much by selling hatching eggs and day-old chicks as I did before enrolment.

G. F. KAIHLER

508 S. Lime St., Lancaster, Pa.

HIS COURSE BROUGHT SUCCESS

OBLETON R. REID, Wofford, Ky.: "I have been engaged in the poultry business for some years, without much success at first. Every year I would lose from 200 to 300 young chickens. I was just stumbling along in the dark. Then I enrolled for your Complete Poultry Course. I consider this the best investment I ever made and advise any person who enters the poultry business to take a Course from the I.C.S. first. The knowledge that I have gained from your instruction has put me on the road to success. Instead of heavy losses I have this year, up to this time, lost only eight or ten chicks, and I have now (June 9th) about four hundred broilers ready for market."

WON HIGHEST HONORS

E. NOREN, Hartford, Snohomish Co., Wash.: "I was a shingle weaver when I enrolled with the I.C.S. for the Poultry Farming Course. I credit the Schools for enabling me to gain the highest honors on White Leghorn birds in the Seattle poultry show. I am now proprietor of the Washington Poultry Farm."

STATE COLLEGE PROFESSOR TESTIFIES

KARL J. KAY, B. S., State Agricultural School, Barnesville, Ga.: "You will note that I have charge of the department of poultry culture in this school. More than a year ago I examined your lesson papers with the intention of introducing them into my classes. Becoming interested I took up the work for myself and I have now about finished your Complete Poultry Course. I can most heartily indorse the Course for its thoroughness, completeness, logical and clear arrangement. It is admirably suited to the novice who knows nothing of chickens and desires to acquire a practical knowledge or to one like myself, who being an expert professional wants to broaden out upon all phases of the subject and secure valuable works that are strictly reliable. Your textbooks are evidently written by some persons knowing the business."

ADDED \$500 PROFIT

T. E. CASTLE, Virginia City, Mont.: "At the time I enrolled with the International Correspondence Schools for the Poultry Farming Course, I was conducting a small poultry plant as a side issue to my business of editing and managing a country newspaper. I had been handling poultry for a number of years and thought I was pretty well versed in the intricacies of the profession, until I took up the study of my Course. I have learned more than I ever thought I knew before and have added \$500 to my profits as proprietor of the Castle Henney. It makes no difference how much one may know of the poultry business, if he will study your Course and apply its teachings he must necessarily make his business a success."

Found His Course Profitable

HARRY L. GOODWIN, Farmington, Me., was a printer 43 years old when he enrolled with the I. C. S. for the Poultry Farming Course. At that time he was interested in poultry and had been for years a writer for the press. He says that his Course has enabled him to secure much better results with Barred Rocks, Rhode Island Reds, and Indian Runner Ducks than he had formerly been able to attain. During the past year he has written 61 articles for publication in farming and poultry journals, for which he is receiving payment, thereby considerably increasing his income. He feels that his Course has already paid for itself in more ways than one, and that it has been a very profitable investment.

HIS MOST SATISFACTORY INVESTMENT

MARTIN J. ROONEY, 408 S. Ohio St., Butte, Mont.: "The I. C. S. Course in Poultry Farming is thorough in every particular. I can honestly say that I consider the price I paid for the Course one of the most satisfactory investments I ever made."

A HELPFUL AND PRACTICAL COURSE

R. F. SNYDER, Ashland, Pa.: "I desire to state that I have gained considerable knowledge from your Course in Agriculture. I am engaged in farming and what I have learned from your Instruction Papers has been very helpful to me. I feel confident that any one wishing to take up agricultural work will derive great benefit from the study of an I. C. S. Agricultural Course. I do not see how the Course could be made any plainer or easier to understand. Any one who can read and write can get along with such a Course without any trouble whatever."

THE BEST OF ITS KIND

FRANK H. PAYNE, 115 Patterson Ave., Ogden, Utah: "I am more than satisfied with my Course in Poultry Farming for which I enrolled in the I. C. S., and can truthfully recommend it to any one wishing a thorough knowledge of the poultry business. I have studied several books on poultry culture, but your Course is the best of its kind."

LEARNED MORE IN 6 MONTHS THAN IN 6 YEARS PREVIOUS

C. H. SIEMER, Bernardsville, N. J.: "The knowledge that I have gained since I started to study your Course in General Farming has been of great assistance to me. I had 6 years of practical farm experience previous to taking the Course, but I have learned more about farming in the few months that I have studied than in the 6 years previous. The textbooks make everything so plain that any one with a common-school education can easily understand them. I feel very confident that the Course will be very helpful to any one engaged in agricultural work."

NO EXCUSE FOR FAILURE

D. H. MCFALLS, White Plains, N. Y.: "I am pleased to express my appreciation of the Poultry Course by the I. C. S. If I had had the knowledge your Course has now furnished me 2 years ago, I would have been spared much anxiety and saved loss, since your paper on feeding alone would have been worth more to me than the cost of the whole Course. To any one having your Course, there need be no more excuse for failures in the poultry business."

Knew Nothing About Poultry—Now Has Two Poultry Farms

Before enrolling for your Course in Poultry Farming, I did not know anything pertaining to poultry; but since I have studied your Course I find it to be most thorough, up to date, and all that you claim for it. Without the knowledge contained in it I would have been practically at a standstill, but I now have about 600 fowls on two farms, and am thinking of starting two more farms. The knowledge I gained from your Course helped me to get from 25 to 32 eggs a week from five hens, from the first of December to the first of March, without injury to the fowls, which now weigh an average of 6½ pounds each. The price of the Course can easily be made up, as the knowledge gained from the Course would advance one's poultry so that the money paid for the Course would not be missed. From the instructions in the Course I have made my own brooders and all of my appliances. Next season I contemplate getting an incubator from the Sales Company, as I looked it over at our poultry show.

I will gladly recommend this Course to any one wishing to know about poultry.

ANDREW J. RASSA
1404 Ashland Ave., Baltimore, Md.

WELL SATISFIED

PHILLIP BECKER, 1910 Prospect Ave., New York, N. Y.: "I desire to state that I find your Course in Agricultural Instruction all that I expected it would be. It not only explains everything, but tells what to do, when to do it, and how to do it. I am very well satisfied with the Course."

SUPERIOR TO OTHER COURSES

W. A. MOORE, 143 Sherman Ave., N. Hamilton, Ont., Can.: "This is to certify that I have nearly completed the I. C. S. Poultry Course and I find it up to date and the best so far. I have taken courses in two other poultry schools and followed the experimental farms and find points completely covered in the I. C. S. Course which all others said they had no data of. Any one desiring a thoroughly practical poultry course can get nothing better, and it would be excellent as preparatory to a residential course."

FIT TO MANAGE A FARM

J. H. PENNINGTON, Pennington Gap, Va.: "My Course in Agriculture has been of great practical value to me, and I am sure that any one who studies your Agricultural Course will be fully able to manage a farm."

AVERAGE EGG YIELD FROM 50 PER CENT. TO 75 PER CENT.

D. BRANNAN, 223 Beech St., Grafton, W. Va.: "I can truly say that since I began to study the Course in Poultry Farming I have had perfect success with my fowls. I have 11 pullets and four cockerels and have been getting from 50 to 75 per cent. egg yield since my flock was 6 months old, and I am not troubled with colds, etc., in my flock as before. The Poultry Farming Course is very good in its teachings with regard to the commercial side of poultry raising; that is, raising fowls for meat and eggs."

THE BEST SOURCE

GILBERT M. BURR, Meshoppen, Pa.: "As a student now completing your Poultry Farming Course, I can heartily recommend it to any one engaged in raising or handling poultry. I do not believe any one can derive as much benefit from any other source as by studying this Course. As a breeder of single-comb White Orpingtons, I find it full of valuable information and practical instruction for all phases of the work."

Manager of Schwab's Poultry Plant

In a recent number of the *Johnstown Daily Democrat* there is a description of the poultry plant recently erected by Chas. M. Schwab, the steel magnate, located at Loretto, Pa., adjoining Mr. Schwab's summer home. The pen is of solid brick, 200 feet long and 15 feet wide, costing about \$18,000. The manager of this splendid plant is an I.C.S. student of the Poultry Farming Course. He says:

"I was a trainman in the freight service of the P. R. R., interested in fancy poultry when I enrolled with the I.C.S. for the Poultry Farming Course. I studied this Course and worked with my birds according to your instructions, with fine success. My flocks became larger and had greater vitality. While working on the railroad I did not average \$50 a month, working all kinds of hours in all weather. Since receiving my Diploma I have full charge of Mr. Schwab's plant that cost \$18,000, and is fitted with the most modern equipment that can be bought."

H. L. HAGGERTY,
R. F. D. No. 1, Loretto, Pa.

== The International == Sanitary Hover and Green Food Grower

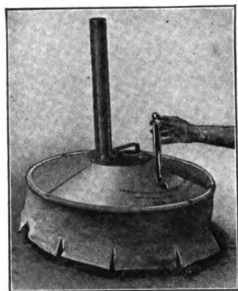

RAISES more chicks and less trouble than any other brooding device ever invented. Warmer near the curtain than at the center, which prevents crowding, trampling, and smothering of chicks. No carpenter work required to set it up—no cutting of holes nor building of platforms. Lamp can be lifted out by a person standing up

—no kneeling in dust or mud. Warmly indorsed by Kellerstrass, Owen Farms, Wm. Cook & Sons, Rufus Delafield, and America's leading poultrymen generally. Fireproof, unbreakable, absolutely reliable.

As a Green Food Grower

The Sanitary Hover is an ideal green food grower. In 8 days it will transform 12 quarts of oats into enough green food to feed 500 laying hens 3 days. Green food in winter means eggs in winter. Eggs in winter mean profit.

Catalog containing hundreds of testimonials free upon request.

International Poultry Sales Company

Box 500

Browns Mills in the Pines, N. J.

HATCHING EGGS

EVERY egg the product of a Rancocas-Strain layer and having in it the marvelous vitality that has caused Rancocas Strain to be recognized as the trade mark of perfection in the poultry world.

Rancocas Strain is the product of careful selecting, careful mating, careful watching, and careful weeding out. No uncertain eggs or weakling chicks at Rancocas. Every egg shipped is a potential chicken of superb health, astonishing vigor, and record-breaking egg capacity. **Ninety per cent. fertility guaranteed.**

Day-Old Chicks

Bounding with life and vigor, able and eager to begin at once to "scratch for themselves." Rancocas Day-Old Chicks have back of them the enviable reputation of the Rancocas Strain—a reputation we prize too highly to jeopardize. Thousands shipped every day during the season—no dissatisfaction.

Order early—there will be many to serve.

Catalog free upon request

International Poultry Sales Company

Box 500

Browns Mills in the Pines, N. J.

CANNOT FAIL TO SUCCEED

BERT WHITE, Box 477, Burlingame, Kans.: "Any one interested in poultry should invest in the Poultry Farming Course with the I. C. S. From personal experience I can say that any one that will study the Course cannot fail to succeed. Each subject is well explained and easily understood. Since I began to study my Course the profits of my flock are rapidly increasing."

WORTH MANY TIMES ITS COST

WILLIAM R. HALLOWAY, River Side Farm, Newark, Md.: "I wish to express my gratitude to the faculty of the International Correspondence Schools for the assistance they have rendered me and the interest they have taken in my progress and success since I enlisted for a Course in Soil Improvement and Farm Crops. The Instruction Papers are very lucid and cover every point of importance with the utmost care, thereby making it easy for the person to grasp the meaning of what is taught. I think any one who contemplates making farming his life vocation will find an International Correspondence Schools' Course in Agriculture worth many times the cost."

HIS COURSE PROFITABLE

J. C. THREHAUSER, Fair Haven, Pa.: "I cannot express my appreciation of the value of your Poultry Farming Course, since the benefits derived are far beyond my anticipation. Since taking your Course I have spent some time at the government experiment station. Their course in some respects is quite like yours, but it is not so extensive or so complete. I have been offered two positions to take charge of poultry farms, both of which I declined, because I can do much better by caring for my own poultry."

WORTH ALL THE POULTRY MAGAZINES PUBLISHED

RALPH W. WESTON, Box 26, Honolulu, Hawaii: "I can say in all faith that the methods and instruction set forth in the I. C. S. Poultry Farming Course are of priceless value. I have applied these methods in a small way and find the results as stated. The Course is worth many times the expenditure of time and money and is more valuable than all the poultry magazines published."

HIS COURSE PROFITABLE

C. L. LAW, 2036 W. 83d St., Cleveland, Ohio: "I have found my Poultry Farming Course very satisfactory. Previous to enrolment with the I. C. S. I had studied poultry raising and had bred poultry to some extent; but I must say that your Course has been of great profit to me."

Dollars and Cents Knowledge

Having been a subscriber to your Mechanical Course in former years, I was pleased to learn that you were issuing a Course in Poultry Farming. Knowing the need of information on this subject, I subscribed for the Course.

In reading and studying the first Instruction Papers, I began to realize the greatness and perfection of the Course. Step by step the student is led to proficiency and also I find that each step has been carefully examined beforehand from one standpoint—the question of dollars and cents. In this lies the crux of the matter, the secret of success.

THOMAS H. POLLARD
916 Eighth Ave., Brooklyn, N. Y.









